

RV Series Automated Dispensing Systems

Operating Manual



Electronic pdf files of Nordson EFD manuals are also available at www.nordsonefd.com

Nordson
EFD

You have selected a reliable, high-quality dispensing system from Nordson EFD, the world leader in fluid dispensing. Nordson EFD automated dispensing systems are designed specifically for industrial dispensing and will provide you with years of trouble-free, productive service.

This manual will help you maximize the usefulness of your automated dispensing system.

Please spend a few minutes to become familiar with the controls and features. Follow our recommended testing procedures. Review the helpful information we have included, which is based on more than 50 years of industrial dispensing experience.

Most questions you will have are answered in this manual. However, if you need assistance, please do not hesitate to contact EFD or your authorized EFD distributor. Detailed contact information is provided on the last page of this document.

The Nordson EFD Pledge

Thank You!

You have just purchased the world's finest precision dispensing equipment.

I want you to know that all of us at Nordson EFD value your business and will do everything in our power to make you a satisfied customer.

If at any time you are not fully satisfied with our equipment or the support provided by your Nordson EFD Product Application Specialist, please contact me personally at 800.556.3484 (US), 401.431.7000 (outside US), or Srini.Subramanian@nordsonefd.com.

I guarantee that we will resolve any problems to your satisfaction.

Thanks again for choosing Nordson EFD.

Srini Subramanian

Srini Subramanian, General Manager

Contents

Contents	3
Introduction	5
Nordson EFD Product Safety Statement	6
Halogenated Hydrocarbon Solvent Hazards	7
High Pressure Fluids	7
Qualified Personnel	7
Intended Use	8
Regulations and Approvals	8
Personal Safety	8
Fire Safety	9
Preventive Maintenance	9
Important Disposable Component Safety Information	10
Action in the Event of a Malfunction	10
Disposal	10
Equipment-Specific Safety Information	11
Specifications	12
Operating Features	14
RV Series System Component Identification	14
RV Front Panel	15
RV Back Panel	15
Camera	16
Installation	17
Unpack the System Components	17
Position the Robot and Install and Connect Components	18
Prepare the Work Surface or Fixture Plate	20
Connect Inputs / Outputs (Optional)	20
Power On the System	21
Concepts	22
About Programs and Commands	22
About Offsets	23
About Marks	24
Overview of the DispenseMotion Software	25
Command Windows	26
Primary View Screen and Tab Bar	27
Secondary View Screen	28
Horizontal and Vertical Toolbar Icons	29
Setup and Dispense Command Icons	30
Navigation and Jogging Window	31
System Setup Screen	32
Camera Screen, Tab Bar, and Icons	33
Template Match and Area Windows	34
Camera Setup Screen	35
Keypad	35

Continued on next page

Contents (continued)

Setup	36
Setting System Parameters	36
Setting Password Protection	39
Setting Up and Calibrating the System (Required).....	40
Verifying the Robot Model, Tip Detection, and Set Z to Focus Selections.....	40
Setting the Optional Tip Alignment Kit Selection	41
Verifying the 4-Axis Selection	42
Setting Up the System Using the Robot Initial Setup Wizard	43
How the System Responds to Needle Z Detect or Needle XY Adjust	52
Changing the Robot Model Selection	52
Setting Up Inputs / Outputs.....	53
Configuring Input / Outputs for a Special Purpose	53
Setting How the System Finds Marks (Optional).....	54
Setting the Units of Measure	55
Restoring the System to the Factory Default Settings	55
Programming.....	56
How to Rotate the Tip and Set the Angle of Rotation	56
Setting the Tip Rotation Angle in the Tip Mode	57
Setting the Tip Rotation Angle in the CCD Mode	58
How to Create and Run a Program	59
How to Add Comments to a Program	60
How to Lock or Unlock a Program	61
How to Measure a Path or Circle on a Workpiece	61
How to Create Patterns	62
Dispense Dot Sample Program.....	62
Lines and Arcs Sample Program	62
Circle Sample Program.....	63
How to Use the Example Icon	63
How to Dispense on Multiple Workpieces in an Array	64
How to Disable Dispensing for Specific Workpieces in an Array	65
How to Create a Mark.....	66
How to Improve the Accuracy of Mark Searches.....	67
How to Use Marks or Fiducial Marks in a Program	68
How to Set Up Auto Purge, Program Cycle Limits, or Fluid Working Life Limits	69
How to Use Point Offset to Adjust All Points in a Program	70
Operation.....	71
Starting the System and Running a Program	71
Running a Program by Scanning a QR Code	71
Pausing During a Dispense Cycle.....	72
Purging the System	72
Updating Offsets.....	72
Shutting Down the System	72
Part Numbers	72
Accessories	73
Safety Enclosures	73
Pre-Configured Output Cables.....	73
Fixture Plates	74
Start / Stop Box.....	74
Tip Detection Kits	74
Mounting Brackets	75
Technical Data.....	76
Dimensions	76
Robot Feet Mounting Hole Template	76
Wiring Diagrams	77
Dispenser Port	77
Ext. Control Port.....	77
I/O Port.....	78
Example Input / Output Connections.....	79

Continued on next page

Contents (continued)

Appendix A, Command Function Reference.....	80
Appendix B, Non-Wizard Setup Procedures.....	97
Setting the Camera Scale.....	97
Setting Up the Optional Tip Detector or Tip Alignment Device.....	98
Setting the Tip-to-Workpiece Offset (Z Clearance) Using the Camera Focus.....	99
Appendix C, DXF File Import.....	100
Overview of the DXF Screen.....	100
Setting DXF Import Preferences.....	101
Importing a DXF File.....	102
Appendix D, QR Code Scanning Setup.....	105
Appendix E, Multi-Needle Setup and Use.....	108
Appendix F, I/O Pin Function Setup.....	113
Appendix G, System Setup for Installing Software Updates.....	115

Introduction

This manual provides installation, setup, programming, operation, and service information for all components of a Nordson EFD RV Series automated dispensing system. Nordson EFD's automated dispensing systems dispense fluid in a preprogrammed pattern onto a workpiece. They are specifically designed and configured for use with Nordson EFD industrial syringe barrel and valve systems. Automated dispensing systems offer the flexibility of working either as a stand-alone system or as a key part of an automated solution and are easily integrated into in-line transfer systems, rotary tables, and pallet assembly lines.

The primary components of an automated dispensing system are the DispenseMotion™ controller, the robot, and the dispensing system components. The robot executes a computer program to dispense fluid in a specific pattern onto a workpiece. Programs are created using the DispenseMotion software installed on the DispenseMotion controller. The dispensing system may be contact or non-contact, with material being dispensed through either a dispensing tip or nozzle. For the purposes of this manual, “dispensing tip” refers to either a tip or a nozzle.

Using the precision-vision camera, the robot can automatically adjust the dispensing program for each workpiece, allowing for variations in the workpiece position or orientation. To accomplish this, the software compares the current workpiece location to within +/- 2.5 mm (0.098") of a reference location that is stored as an image file (called a mark file) in the program. If the robot detects a difference in the X and Y positions and / or the angle of rotation of the workpiece, it adjusts the dispensing path to correct for the difference.



Nordson EFD Product Safety Statement

WARNING

The safety message that follows has a WARNING level hazard.
Failure to comply could result in death or serious injury.



ELECTRIC SHOCK

Risk of electric shock. Disconnect power before removing covers and / or disconnect, lock out, and tag switches before servicing electrical equipment. If you receive even a slight electrical shock, shut down all equipment immediately. Do not restart the equipment until the problem has been identified and corrected.

CAUTION

The safety messages that follow have a CAUTION level hazard.
Failure to comply may result in minor or moderate injury.



READ MANUAL

Read manual for proper use of this equipment. Follow all safety instructions. Task- and equipment-specific warnings, cautions, and instructions are included in equipment documentation where appropriate. Make sure these instructions and all other equipment documents are accessible to persons operating or servicing equipment.



MAXIMUM AIR PRESSURE

Unless otherwise noted in the product manual, the maximum air input pressure is 7.0 bar (100 psi). Excessive air input pressure may damage the equipment. Air input pressure is intended to be applied through an external air pressure regulator rated for 0 to 7.0 bar (0 to 100 psi).



RELEASE PRESSURE

Release hydraulic and pneumatic pressure before opening, adjusting, or servicing pressurized systems or components.



BURNS

Hot surfaces! Avoid contact with the hot metal surfaces of heated components. If contact can not be avoided, wear heat-protective gloves and clothing when working around heated equipment. Failure to avoid contact with hot metal surfaces can result in personal injury.

Nordson EFD Product Safety Statement (continued)

Halogenated Hydrocarbon Solvent Hazards

Do not use halogenated hydrocarbon solvents in a pressurized system that contains aluminum components. Under pressure, these solvents can react with aluminum and explode, causing injury, death, or property damage. Halogenated hydrocarbon solvents contain one or more of the following elements.

Element	Symbol	Prefix
Fluorine	F	“Fluoro-”
Chlorine	Cl	“Chloro-”
Bromine	Br	“Bromo-”
Iodine	I	“Iodo-”

Check the Safety Data Sheet (SDS) or contact your material supplier for more information. If you must use halogenated hydrocarbon solvents, contact your EFD representative for compatible EFD components.

High Pressure Fluids

High pressure fluids, unless they are safely contained, are extremely hazardous. Always release fluid pressure before adjusting or servicing high pressure equipment. A jet of high pressure fluid can cut like a knife and cause serious bodily injury, amputation, or death. Fluids penetrating the skin can also cause toxic poisoning.

WARNING

Any injury caused by high pressure liquid can be serious. If you are injured or even suspect an injury:

- Go to an emergency room immediately.
- Tell the doctor that you suspect an injection injury.
- Show the doctor the following note.
- Tell the doctor what kind of material you were dispensing.

Medical Alert — Airless Spray Wounds: Note to Physician

Injection in the skin is a serious traumatic injury. It is important to treat the injury surgically as soon as possible. Do not delay treatment to research toxicity. Toxicity is a concern with some exotic coatings injected directly into the bloodstream.

Qualified Personnel

Equipment owners are responsible for making sure that EFD equipment is installed, operated, and serviced by qualified personnel. Qualified personnel are those employees or contractors who are trained to safely perform their assigned tasks. They are familiar with all relevant safety rules and regulations and are physically capable of performing their assigned tasks.

Nordson EFD Product Safety Statement (continued)

Intended Use

Use of EFD equipment in ways other than those described in the documentation supplied with the equipment may result in injury to persons or damage to property. Some examples of unintended use of equipment include:

- Using incompatible materials.
- Making unauthorized modifications.
- Removing or bypassing safety guards or interlocks.
- Using incompatible or damaged parts.
- Using unapproved auxiliary equipment.
- Operating equipment in excess of maximum ratings.
- Operating equipment in an explosive atmosphere.

Regulations and Approvals

Make sure all equipment is rated and approved for the environment in which it is used. Any approvals obtained for Nordson EFD equipment will be voided if instructions for installation, operation, and service are not followed. If the equipment is used in a manner not specified by Nordson EFD, the protection provided by the equipment may be impaired.

Personal Safety

To prevent injury, follow these instructions:

- Do not operate or service equipment unless you are qualified.
- Do not operate equipment unless safety guards, doors, and covers are intact and automatic interlocks are operating properly. Do not bypass or disarm any safety devices.
- Keep clear of moving equipment. Before adjusting or servicing moving equipment, shut off the power supply and wait until the equipment comes to a complete stop. Lock out power and secure the equipment to prevent unexpected movement.
- Make sure spray areas and other work areas are adequately ventilated.
- When using a syringe barrel, always keep the dispensing end of the tip pointing towards the work and away from the body or face. Store syringe barrels with the tip pointing down when they are not in use.
- Obtain and read the Safety Data Sheet (SDS) for all materials used. Follow the manufacturer's instructions for safe handling and use of materials and use recommended personal protection devices.
- Be aware of less-obvious dangers in the workplace that often cannot be completely eliminated, such as hot surfaces, sharp edges, energized electrical circuits, and moving parts that cannot be enclosed or otherwise guarded for practical reasons.
- Know where emergency stop buttons, shutoff valves, and fire extinguishers are located.
- Wear hearing protection to protect against hearing loss that can be caused by exposure to vacuum exhaust port noise over long periods of time.

Nordson EFD Product Safety Statement (continued)

Fire Safety

To prevent a fire or explosion, follow these instructions:

- Shut down all equipment immediately if you notice static sparking or arcing. Do not restart the equipment until the cause has been identified and corrected.
- Do not smoke, weld, grind, or use open flames where flammable materials are being used or stored.
- Do not heat materials to temperatures above those recommended by the manufacturer. Make sure heat monitoring and limiting devices are working properly.
- Provide adequate ventilation to prevent dangerous concentrations of volatile particles or vapors. Refer to local codes or the SDS for guidance.
- Do not disconnect live electrical circuits when working with flammable materials. Shut off power at a disconnect switch first to prevent sparking.
- Know where emergency stop buttons, shutoff valves, and fire extinguishers are located.

Preventive Maintenance

As part of maintaining continuous trouble-free use of this product, Nordson EFD recommends the following simple preventive maintenance checks:

- Periodically inspect tube-to-fitting connections for proper fit. Secure as necessary.
- Check tubing for cracks and contamination. Replace tubing as necessary.
- Check all wiring connections for looseness. Tighten as necessary.
- Clean: If a front panel requires cleaning, use a clean, soft, damp rag with a mild detergent cleaner. DO NOT USE strong solvents (MEK, acetone, THF, etc.) as they will damage the front panel material.
- Maintain: Use only a clean, dry air supply to the unit. The equipment does not require any other regular maintenance.
- Test: Verify the operation of features and the performance of equipment using the appropriate sections of this manual. Return faulty or defective units to Nordson EFD for replacement.
- Use only replacement parts that are designed for use with the original equipment. Contact your Nordson EFD representative for information and advice.

Nordson EFD Product Safety Statement (continued)

Important Disposable Component Safety Information

All Nordson EFD disposable components, including syringe barrels, cartridges, pistons, tip caps, end caps, and dispense tips, are precision engineered for one-time use. Attempting to clean and re-use components will compromise dispensing accuracy and may increase the risk of personal injury.

Always wear appropriate protective equipment and clothing suitable for your dispensing application and adhere to the following guidelines:

- Do not heat syringe barrels or cartridges to a temperature greater than 38° C (100° F).
- Dispose of components according to local regulations after one-time use.
- Do not clean components with strong solvents (MEK, acetone, THF, etc.).
- Clean cartridge retainer systems and barrel loaders with mild detergents only.
- To prevent fluid waste, use Nordson EFD SmoothFlow™ pistons.

Action in the Event of a Malfunction

If a system or any equipment in a system malfunctions, shut off the system immediately and perform the following steps:

1. Disconnect and lock out system electrical power. If using hydraulic and pneumatic shutoff valves, close and relieve pressure.
2. For Nordson EFD air-powered dispensers, remove the syringe barrel from the adapter assembly. For Nordson EFD electro-mechanical dispensers, slowly unscrew the barrel retainer and remove the barrel from the actuator.
3. Identify the reason for the malfunction and correct it before restarting the system.

Disposal

Dispose of equipment and materials used in operation and servicing according to local codes.



Nordson EFD Product Safety Statement (continued)

Equipment-Specific Safety Information

The following safety information is specific to Nordson EFD automated dispensing systems.

European Community

To meet the requirements of the European Community (CE) safety directives, the robot must be placed in an enclosure. The enclosure prevents an operator from entering the robot's work area and generates an emergency stop signal if the door switch is opened while the robot is running.

WARNING

Install the input/output safety plug only to bypass the door switch. When this plug is installed, the installer assumes all safety liability.

Installation Location

Do not store, install, or operate the robot in a location where it is exposed to the following:

- Temperatures lower or higher than 0–40° C (50–104° F) or humidity lower or higher than 20–95%
- Direct sunlight
- Electrical noise
- Flammable or corrosive gases
- Dust or iron powder
- Sources of splashing water, oil, or chemicals
- Radioactive materials, magnetic fields, or vacuum rooms

Power and Grounding

- Connect the robot and accessories to a properly grounded power source.
- Make sure the system is connected to the correct voltage.

Operation and Service

- Turn on the dust collection system before operating the robot.
- Do not drop or spill foreign objects or material, such as screws or liquids, into the robot.
- Do not overload the robot.
- Do not touch any part of the robot while it is running. Load and unload workpieces or material only when the robot is stopped.
- Disconnect and lock out power to the system before changing fixtures or tooling.
- Use only a neutral detergent for cleaning. Do not use alcohol, benzene, or thinner.

Specifications

NOTE: Specifications and technical details are subject to change without prior notification.

Item / Model	R3V	R4V	R6V
Number of axes	4	4	4
Maximum working area (X / Y / Z / R°)	300 / 300 / 150 mm / ±999° (12 / 12 / 6" / ±999°)	400 / 400 / 150 mm / ±999° (16 / 16 / 6" / ±999°)	620 x 500 x 150 mm / ±999° (24 / 20 / 6" / ±999°)
Workpiece payload	10.0 kg (22.0 lb)	10.0 kg (22.0 lb)	10.0 kg (22.0 lb)
Tool payload	3.0 kg (6.6 lb)	3.0 kg (6.6 lb)	3.0 kg (6.6 lb)
Weight	50.0 kg (110.2 lb)	55.0 kg (121.3 lb)	61.0 kg (134.5 lb)
Dimensions	645W x 914H x 552D mm (25W x 36H x 22D")	745W x 914H x 652D mm (29W x 36H x 26D")	965W x 914H x 752D mm (38W x 36H x 30D")
Maximum speed (XY / Z)	800 / 320 mm/s (31 / 13"/s)	800 / 320 mm/s (31 / 13"/s)	800 / 320 mm/s (31 / 13"/s)
Maximum speed (R°)	720°/s	720°/s	720°/s
Drive system	3-phase micro-stepping motor	3-phase micro-stepping motor	3-phase micro-stepping motor
Memory capacity	PC storage	PC storage	PC storage
Data storage	PC storage / USB	PC storage / USB	PC storage / USB
General purpose I/O	8 inputs / 8 outputs (16 / 16 optional)	8 inputs / 8 outputs (16 / 16 optional)	8 inputs / 8 outputs (16 / 16 optional)
Drive method	PTP and CP	PTP and CP	PTP and CP
Dispensing controller	External	External	External
Input AC (to power supply)	100–240 VAC, ±10%, 50/60Hz, 20 Amp maximum, 320 W	100–240 VAC, ±10%, 50/60Hz, 20 Amp maximum, 320 W	100–240 VAC, ±10%, 50/60Hz, 20 Amp maximum, 320 W
Interpolation	4 axes (4D space)	4 axes (4D space)	4 axes (4D space)
Repeatability (XY / Z)*	±0.008 mm/axis	±0.008 mm/axis	±0.008 mm/axis
Repeatability (R°)*	±0.005°	±0.005°	±0.005°
Working temperature	10–40° C (50–104° F)	10–40° C (50–104° F)	10–40° C (50–104° F)
Vision	CCD smart camera Rotating-mount camera (optional)	CCD smart camera Rotating-mount camera (optional)	CCD smart camera Rotating-mount camera (optional)
DispenseMotion software	Included	Included	Included
Tip detection / alignment system	Optional	Optional	Optional
Approvals	CE, RoHS, WEEE, China RoHS		
*Repeatability results may vary depending on the method of measurement.			

Specifications (continued)

RoHS标准相关声明 (China RoHS Hazardous Material Declaration)

产品名称 Part Name	有害物质及元素 Toxic or Hazardous Substances and Elements					
	铅 Lead (Pb)	汞 Mercury (Hg)	镉 Cadmium (Cd)	六价铬 Hexavalent Chromium (Cr6)	多溴联苯 Polybrominated Biphenyls (PBB)	多溴联苯醚 Polybrominated Diphenyl Ethers (PBDE)
外部接口 External Electrical Connectors	X	0	0	0	0	0
<p>0: 表示该产品所含有的危险成分或有害物质含量依照EIP-A, EIP-B, EIP-C 的标准低于SJ/T11363-2006 限定要求。 Indicates that this toxic or hazardous substance contained in all the homogeneous materials for this part, according to EIP-A, EIP-B, EIP-C is below the limit requirement in SJ/T11363-2006.</p> <p>X: 表示该产品所含有的危险成分或有害物质含量依照EIP-A, EIP-B, EIP-C 的标准高于SJ/T11363-2006 限定要求。 Indicates that this toxic or hazardous substance contained in all the homogeneous materials for this part, according to EIP-A, EIP-B, EIP-C is above the limit requirement in SJ/T11363-2006.</p>						

WEEE Directive



This equipment is regulated by the European Union under WEEE Directive (2012/19/EU). Refer to www.nordsonefd.com/WEEE for information about how to properly dispose of this equipment.

Operating Features

RV Series System Component Identification

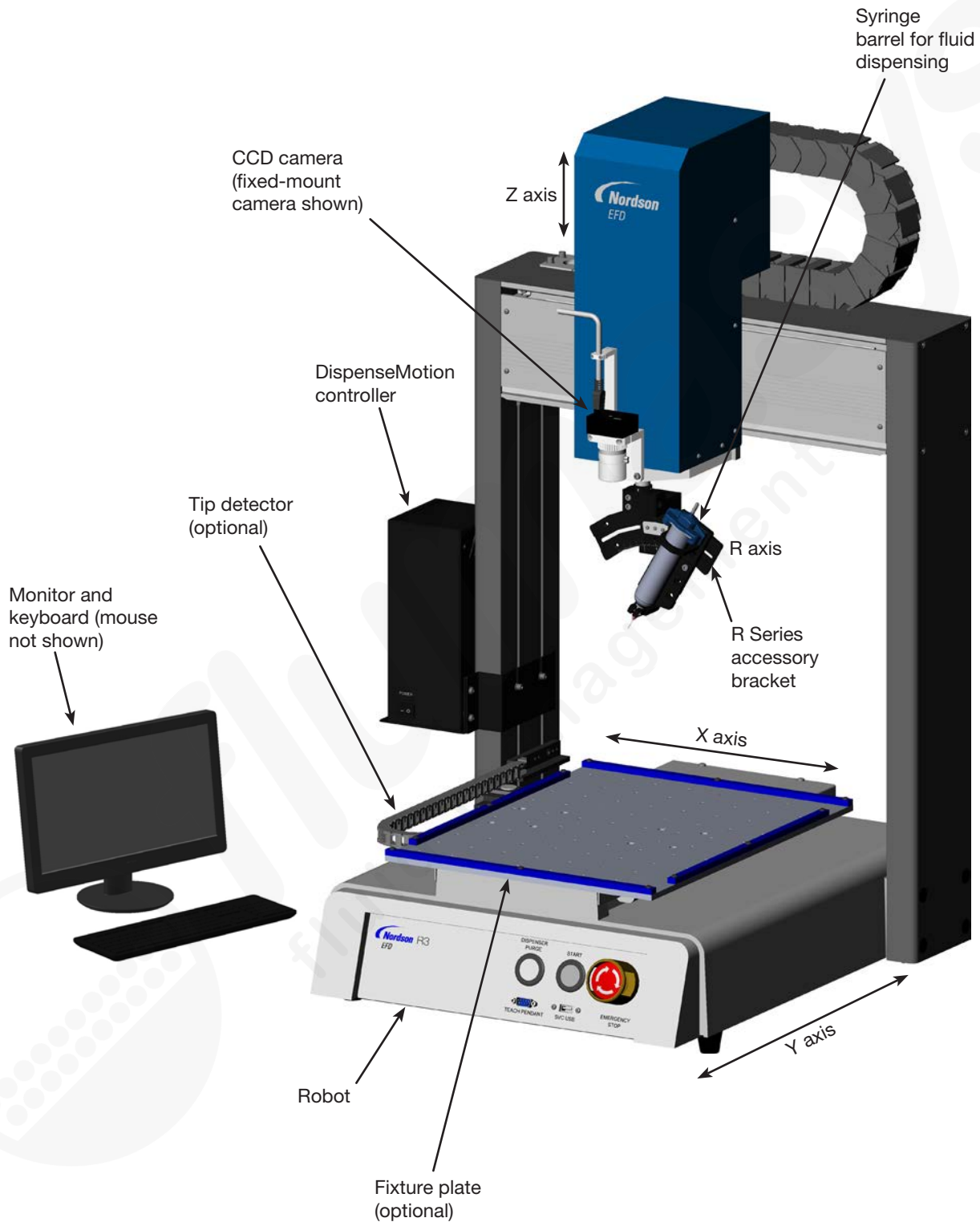

Operating Features (continued)

RV Front Panel

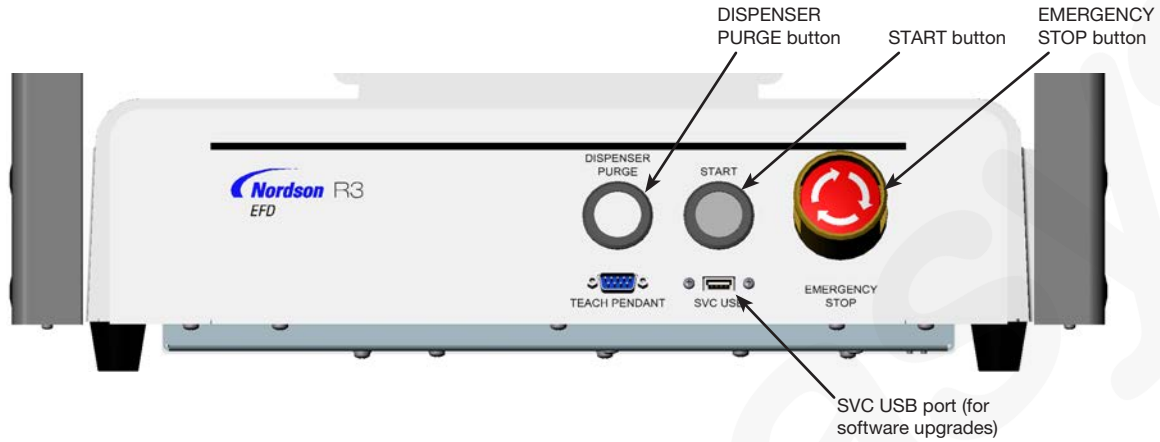

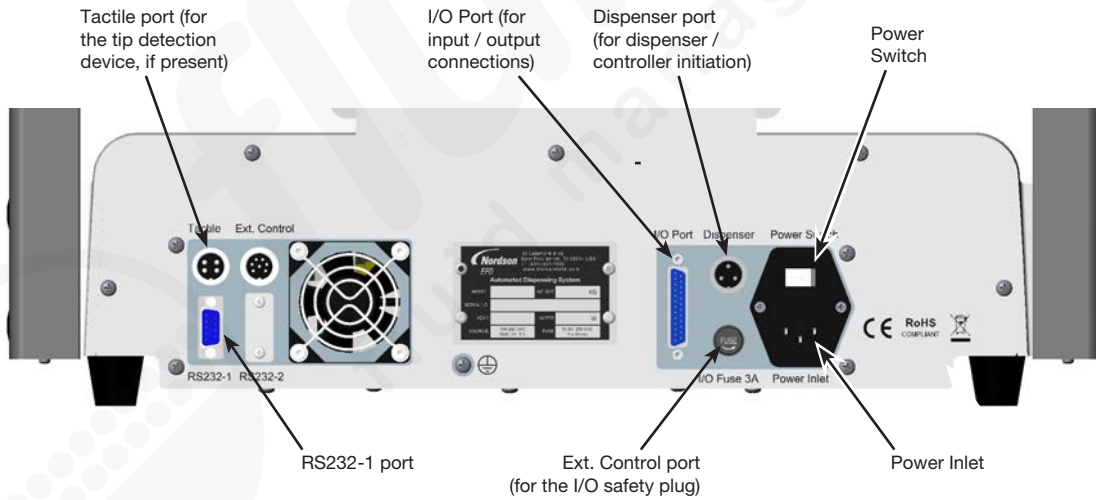

RV Back Panel



Camera

Your system includes a smart-vision CCD camera, allowing you to view the work surface or fixture plate and to obtain a very sharp focus. Two types of CCD camera are used with RV Series systems: fixed-mount and rotating-mount (R-mount). A fixed-mount camera is stationary. An R-mount camera is installed on the R axis, so it moves and rotates with the R axis.

Fixed-Mount CCD Camera	Features	How to Focus
 <p>Exposure dial</p> <p>Focus dial</p>	Converts the analog camera image pixels to digital values for extremely precise image management	Use the two adjustable dials: <ul style="list-style-type: none"> • The upper dial adjusts the exposure (how much light is allowed into the image). • The lower dial focuses the image. • The default focus height is zero (0).
	Fixed focal length	
	Variety of lenses available (for different focal lengths, fields of view, etc.).	
R-Mount CCD Camera	Features	How to Focus
	Converts the analog camera image pixels to digital values for extremely precise image management	<ul style="list-style-type: none"> • Move the camera up or down to focus the image.
	Mounts on the R-axis of the robot, allowing multiple substrate viewing orientations at 0° or 90° angles and also the ability to focus on multiple substrate heights within a single program.	
	Fixed focal length (must move the camera up and down to focus it)	

Installation

Use this section in tandem with the Quick Start Guide and the valve system manuals to install all components of the system.

Unpack the System Components

CAUTION

Unpacking the robot requires a minimum of two people. Do not attempt to lift the robot without assistance.

1. Remove all system components and ship-with items from the packaging.
2. With assistance, carefully lift the robot by its base and transfer it to a stable workbench. Never lift the robot by its cross member.

NOTE: All units are shipped from the factory with foam protectors that secure the worktable to the X axis and the Z axis to prevent movement and damage during shipment. Nordson EFD recommends retaining all packing material for use if the robot is shipped or moved in the future.

3. Remove the protective foam covers and tape.
4. Double-check the shipping box to ensure you have removed everything.

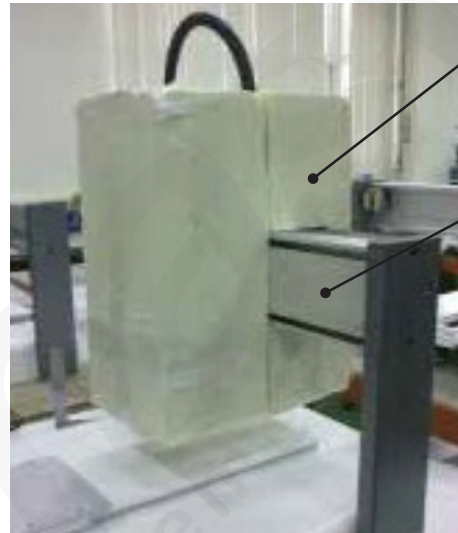

Foam protector





Cross member (do not use to lift the robot)

Position the Robot and Install and Connect Components

Refer to the Quick Start Guide and to this section as needed to install the system components and make connections.

NOTES:

- The components of an automated dispensing system vary. Steps for a complete system with all available components are provided in this manual and in the Quick Start Guide. Perform only the steps that apply to your system.
- If the system is being used in the European Community, the robot is shipped with an enclosure or light curtain that (1) prevents an operator from entering the robot's work area and (2) generates an emergency stop signal if the enclosure door switch is opened while the robot is running.

Applicability	Item	Components to Install or Connect	Installation Tasks
All models	Input/output safety plug (SHORTED)		<ul style="list-style-type: none"> ❑ Connect the input/output safety plug to the Ext. Control port to bypass the door switch. <div style="background-color: #e0f0ff; padding: 5px; text-align: center;"> ⚠ CAUTION </div> <p>Install this plug only if you want to bypass the door switch. When this plug is installed, the customer assumes all safety liability.</p>
All models	DispenseMotion controller		<ul style="list-style-type: none"> ❑ Mount the DispenseMotion controller on the shelf. ❑ Install the shelf-and-controller assembly on the left upright bracket. ❑ Make the connections shown on the Quick Start Guide.
All models	CCD camera	 <p style="text-align: center;">Fixed-mount R-mount</p>	<ul style="list-style-type: none"> ❑ (Optional for the fixed-mount camera only) Install the provided optional lenses. ❑ Install the camera and bracket assembly. ❑ Connect the camera cable to the camera. ❑ Route the camera cable through the dragon chain on the Z axis. ❑ Connect the cable to USB-CCD on the DispenseMotion controller.
All models	Tip detector or tip alignment kit (optional)		<ul style="list-style-type: none"> ❑ Install the tip detector or tip alignment kit. ❑ Connect the cable to the Tactile port on the back of the robot.

Continued on next page

Position the Robot and Install and Connect Components (continued)

Applicability	Item	Components to Install or Connect	Installation Tasks
All models	Monitor, keyboard, and mouse (not shown); dongle for wireless keyboard and mouse		<ul style="list-style-type: none"> <input type="checkbox"/> Connect the monitor. <input type="checkbox"/> Connect the wireless keyboard and mouse dongle to USB 4 on the DispenseMotion controller.
All models	Dispenser components	As applicable	<ul style="list-style-type: none"> <input type="checkbox"/> Mount the syringe barrel or dispensing valve holder (as applicable) on the Z axis; choose mounting holes that allow a maximum workpiece clearance but also allow the dispensing tip to reach all areas on the workpiece where dispensing is required. <input type="checkbox"/> Refer to the dispensing equipment manuals for all other dispensing system installation steps.

Prepare the Work Surface or Fixture Plate

Prepare the robot work surface or fixture plate for secure placement of the workpiece. Refer to “Fixture Plates” on page 74 for fixture plate part numbers. A fixture plate mounting hole template is provided below.

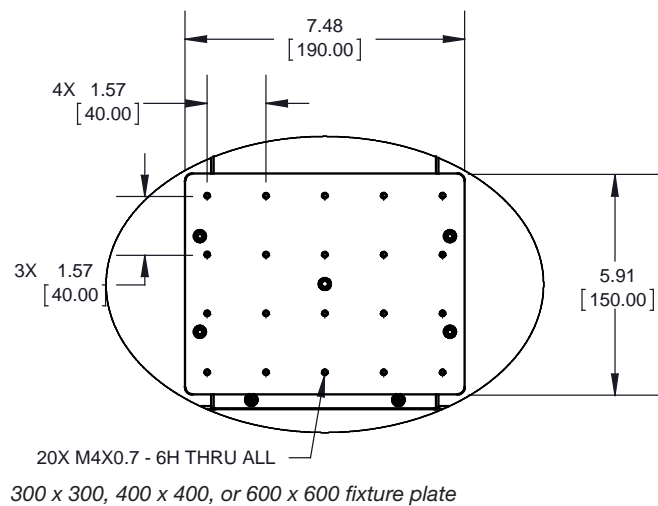

Connect Inputs / Outputs (Optional)

All automated dispensing systems provide 8 standard inputs and 8 standard outputs. Connect input / output wiring to the I/O PORT connection on the back of the robot. For a wiring diagram, refer to “I/O Port” on page 78. There are several ways to use the system inputs / outputs. Refer to “Setting Up Inputs / Outputs” on page 53 for additional information on inputs / outputs.

Power On the System

After the system is fully installed, including the dispensing system components, switch on the system to verify the installation.

1. Make sure the following installation tasks are complete:
 - All applicable system components are installed (refer to “Installation” on page 17).
 - Input/output safety plug is installed (if applicable).
 - EMERGENCY STOP button on the front panel of the robot is not depressed.
2. Switch on the DispenseMotion controller, monitor, and robot.
3. Double-click the DispenseMotion icon to open the dispensing software.
4. Click HOME.

The robot moves the camera to the home position (0,0,0) and the system is ready.



5. Enable the dispensing system, including the valve controller. Refer to the dispensing equipment manuals as needed.
6. Refer to the following sections to set up the system and to create programs for your applications:
 - “Concepts” on page 22
 - “Overview of the DispenseMotion Software” on page 25
 - “Setup” on page 36
 - “Programming” on page 56

Concepts

Before creating any programs, make sure you understand the concepts explained in this section.

About Programs and Commands

A program is a set of commands stored as a file. Each command is stored in the file as a numbered address. Commands can be subdivided into the following command types:

- A setup command sets a program-level parameter, such as an XYZR coordinate or the Z clearance height.
- A dispense command is tied to an XYZR coordinate and automatically sends a signal to the dispensing system to execute the dispense command.

When the robot executes a program, it steps through each address in sequence and executes the command contained in that address. If an address contains a setup command, the system registers that command. If an address contains a dispense command, the robot moves the X, Y, Z, and R axes to the location specified for that command and then performs the dispense command.

Dispense commands are the building blocks of patterns. To program a dispense command, the dispensing tip is jogged to the desired XYZR location and then a dispense command is registered for that location. This action is repeated until the desired dispensing pattern is complete. Several examples are provided below.

Setup commands dictate how dispense commands will be executed. Nordson EFD recommends inserting setup commands at the beginning of a program. The following setup commands are the most commonly used: Backtrack Setup, Dispense Dot Setup, Dispense End Setup, Line Dispense Setup, Line Speed, and Z Clearance Setup.

Dispense Command Examples

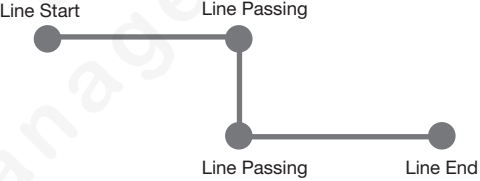
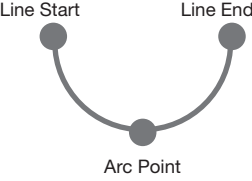
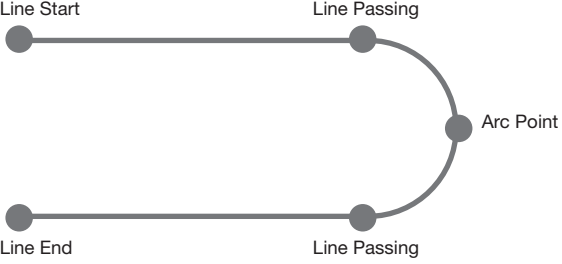
Commands	Resulting Pattern
To program the robot to dispense a dot of fluid, an XYZR location is registered as a DISPENSE DOT command.	 DISPENSE DOT
To program the robot to dispense a bead of fluid along a linear path, the XYZR location of the start of the line is registered as a LINE START command. The locations where the tip changes direction are registered as LINE PASSING commands. The location where the bead of fluid ends is registered as a LINE END command.	
To dispense a bead of fluid in an arc, the XYZR location of the start of the bead is registered as a LINE START command. The high point of the arc is registered as an ARC POINT command. The end of the arc is registered as a LINE END command.	
Lines and arcs can also be combined to dispense a bead of fluid along a complex path.	

About Programs and Commands (continued)

Best Practices for Programming

- Insert dispense setup commands at the beginning of the program.
- Insert mark commands before any dispense commands.
- Insert dispense commands after inserting setup and mark commands.
- Insert the End Program command at the end of all programs.

About Offsets

Offset is the distance between two components. The system must be “taught” the following offsets before any programs are created:

- Camera-to-tip offset: the distance between the center of the camera view and the center of the dispensing tip (this is an XY offset).
- Tip-to-workpiece offset: (1) the distance between the bottom of the tip and the workpiece for contact applications or (2) the distance between the bottom of the nozzle and the workpiece for non-contact applications (this is the Z height clearance).

These offsets must be properly calibrated to make sure the dispensing tip follows the same path as the camera and to compensate for slight variations in height that occur when a dispensing tip or nozzle is changed.

Offsets are taught to the robot during the setup and calibration process, which is guided by the Robot Initial Setup wizard. This process must be performed for initial startup and also after any change to the system. Examples of system changes include the following:

- Any time a component installed on the Z axis (such as the syringe barrel or camera) is moved.
- Any time a dispensing tip or nozzle is changed.

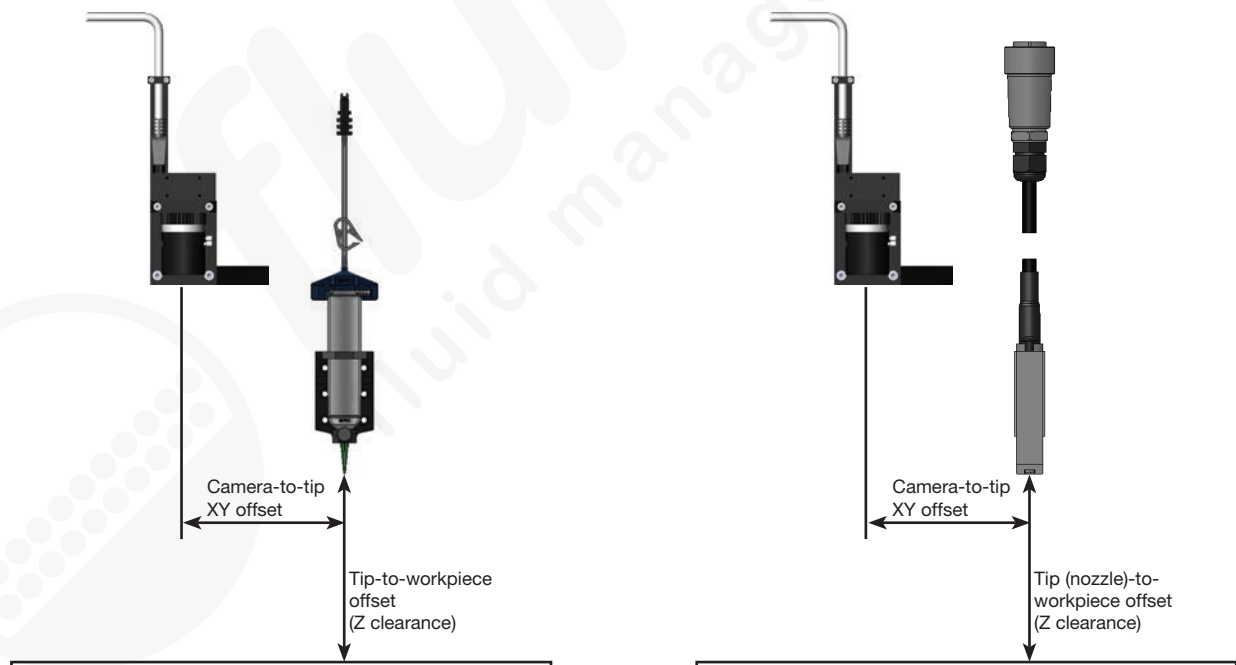

Illustration of camera-to-tip offset (also referred to as XY offset) and tip-to-workpiece offset (also referred to as tip height or Z clearance)

About Marks

To recognize that a workpiece is present or to determine its orientation on the fixture plate, the system uses marks and fiducial marks. Marks are reference images (pictures of a small area on a workpiece) taken by the camera and stored in a location called the Mark Library. The Mark Library appears in the Secondary View screen when the Camera tab is selected. The stored images are shown in sockets in the Mark Library. Picture sockets are blank if they do not contain a stored image.

A mark is a single image that the system uses to find a specific location on a workpiece. Fiducial marks are two mark images that are used conjointly to (1) identify whether a workpiece is present in the proper XY location and (2) to understand its angle of rotation, and then to make automatic adjustments to the program accordingly.



Camera screen shown in the Primary View screen and the Mark Library shown in the Secondary View screen

Best Practices For Selecting a Mark Image

- The selection should be on the actual workpiece (not on the fixture plate) because it is the workpiece position that the system adjusts to.
- The selection should be unique. There should be only one selection of its kind within the camera view. For example, don't choose one of many small circles that are within the camera view.
- Sharp features are best. For example, the intersection of two lines in the capital letter T would be better for a mark image than the center of a circle, which possesses no finite lines.
- An actual dispensing position, such as the corner of a silk-screened solder pad, is more effective than the broken corner edge of a pallet of circuit boards because of the differences in their manufacturing precision.
- The further away fiducial marks are from each other, the more precise the system will be in locating them on a workpiece.

Mark Image Files

You can store 240 mark images in the sockets available in the Mark Library. The Mark Library appears in the Secondary View screen (refer to "Secondary View Screen" on page 28 for more information). These marks are stored as files on the DispenseMotion controller under Documents\mark.

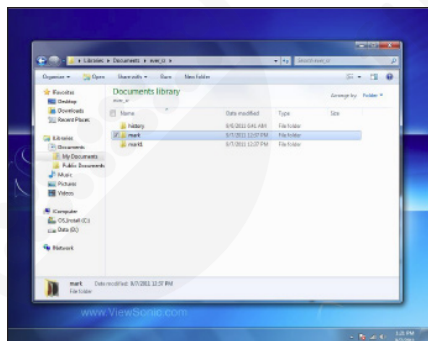

Location of mark image files on the DispenseMotion controller

Overview of the DispenseMotion Software

This section provides an overview of the all the DispenseMotion software screens, windows, and icons. This information is provided for your reference as needed. To set up the system and create dispensing programs, refer to “Setup” on page 36 and “Programming” on page 56. The software opens at the Program screen.

The screenshot shows the main software interface with several callout boxes providing references to other pages:

- Top Left:** Refer to “Horizontal and Vertical Toolbar Icons” on page 29.
- Top Center:** Command address (A): Double-click to open the command drop-down menu; select a command to open its command window. Refer to “Command Windows” on page 26.
- Top Right:** Refer to “Primary View Screen and Tab Bar” on page 27.
- Right Side:** Refer to “Secondary View Screen” on page 28.
- Far Right:** Refer to “Horizontal and Vertical Toolbar Icons” on page 29.
- Bottom Left:** Refer to “Camera Screen, Tab Bar, and Icons” on page 33.
- Bottom Center-Left:** Refer to “System Setup Screen” on page 32.
- Bottom Center-Right:** Refer to “Primary View Screen and Tab Bar” on page 27.
- Bottom Right (Top):** Refer to “Setup and Dispense Command Icons” on page 30.
- Bottom Right (Bottom):** Refer to “Navigation and Jogging Window” on page 31.

Command Windows

When you double-click a command address line on the Program screen, a drop-down menu of all available commands appears. Select any command to open the window for that command. Each command window contains the parameters, if any, that can be set for the command. Refer to “Appendix A, Command Function Reference” on page 80 for detailed information on all commands and associated parameters.

Command address (A):
Double-click to open the
command drop-down menu.

Command edit drop-down menu:
Double-click a command to open
its command window.



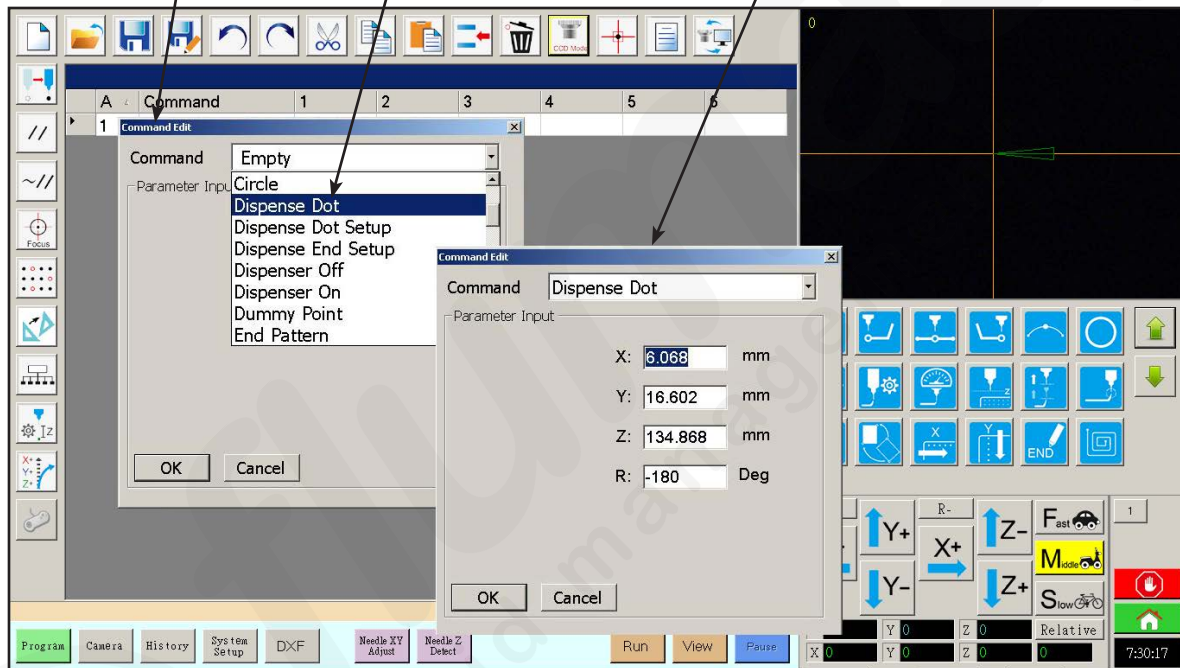





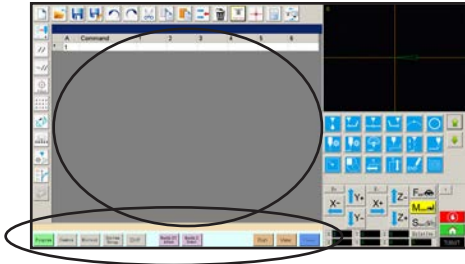

Command window: Enter parameters for
the command in this window. Refer to
“Appendix A, Command Function Reference”
on page 80 for detailed information on all
commands.



Primary View Screen and Tab Bar

The Primary View screen changes depending on the selected tab. All the tabs are visible at all times.



Tab Name	Tab Color When Selected	Function
Program		Shows the command view; used to create programs.
Camera		Shows the actual camera view; used to perform all camera-related functions.
System Setup		Shows the settings screen; used to view or change system-level settings or parameters.
DXF		Allows you to load drawings in DXF format into the DispenseMotion software. Refer to “Appendix C, DXF File Import” on page 100 for more information.
Needle XY Adjust		Automatically checks and adjusts the XY offsets without touching the tip to any surface. This button is present only when Needle XY Adjust is enabled on the System Setup screen. The system must be properly setup as described under “Setting Up and Calibrating the System (Required)” on page 40.
Needle Z Detect		Automatically checks and adjusts the tip-to-workpiece offset (Z clearance) then performs a Needle XY Adjust. This button is present only when Tip Detect Device is enabled on the System Setup screen. The system must be properly setup as described under “Setting Up and Calibrating the System (Required)” on page 40.
Teach		When the optional start / stop box is connected, this indicator appears on the tab bar and flashes when the robot is in the safety bypass mode. When the Teach indication is present, the Run button is disabled.
Run		Runs the selected program.
View		Runs the selected program without dispensing and also centers the camera on the dispense path.
Pause		Pauses the program that is currently running. When you click on Pause, the button changes to Continue.

Secondary View Screen

The Secondary View screen changes depending on the selected tabs and icons.

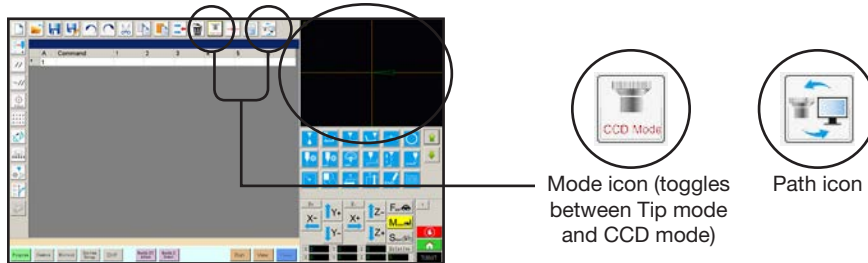

Selected Tab	Tab Color When Selected	Secondary Screen Display	Function
Program		<p>When the Path icon is toggled ON:</p> <p>When the Path icon is toggled OFF:</p>	<p>When the Path icon is toggled on, shows a visual representation of the programmed pattern and the Path mode icons. Refer to “Horizontal and Vertical Toolbar Icons” on page 29 an explanation of the icons.</p> <p>When the Path icon is toggled OFF, shows an actual view of the fixture plate or workpiece surface as seen by the camera.</p>
Camera		<p>Mark Library:</p>	Stores up to 240 mark files.
System Setup		<p>Path view and keypad:</p>	The keypad is used to enter numeric values. Refer to “Keypad” on page 35.

Horizontal and Vertical Toolbar Icons

Use the icons located on the horizontal and vertical toolbars to manage files, insert certain commands, and perform other functions as described below.

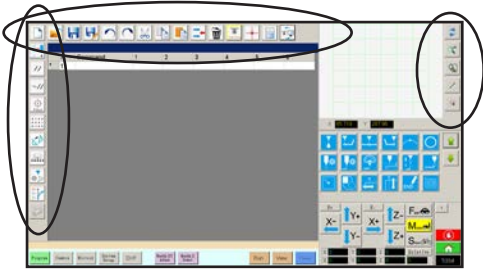

Icon Name	Icon	Function
A New File		Creates a new file
Open a File		Opens a file
Save		Saves the open file
Save as		Saves the open file as a new file name
Undo		Undoes the last command
Redo		Restores the last Undo action
Cut		Cuts a selection
Copy		Copies a selection
Paste		Pastes a selection
Insert		Inserts a memory address
Delete		Deletes the current memory address
CCD Mode		Toggles the system between camera mode and tip mode
Tip Mode		Toggles the system between camera mode and Tip Mode
Match		Centers the camera on a mark selected in the Mark Library (camera must be near the mark on the workpiece)
Example		Provides sample programs that contain examples of the commands you can use to create programs
Path		Switches the Secondary view screen from the Camera view to the Grid view (Path mode)

Icon Name	Icon	Function
Light		(If present) Allows temporary override of the Light settings
Refresh		(Path mode only) Refreshes the Secondary View screen
See all		(Path mode only) Shows all the programmed points on the Secondary View screen
Magnify		(Path mode only) Magnifies an area of the Secondary View screen
Reverse line		(Path mode only) Reverses the direction of the programmed points
Select entity		(Path mode only) Selects a group of points
Move		Moves the tip or camera to the XYZR location of a selected address (if the address has a location value)
Enable Address		Re-enables an address that was previously disabled using Disable Address
Disable Address		Disables a command in the program (re-enable the command by clicking Enable Address while in the selected address)
Focus		Automatically moves the Z position to the focus position based on the initial setup
Step & Repeat Block		For a Step & Repeat command, disables dispensing onto workpieces at selected locations in an array
Transform		Aligns the program points of an uploaded DXF drawing with their actual locations on a workpiece
Extend Step & Repeat		Expands all the commands in a Step & Repeat command (can only be undone using the Undo icon)
Change Z Value		Changes the Z value in a command or in a list of selected commands in a program (mainly used to fine-tune and adjust the dispensing gap)
Point Offset		Changes or moves all program points if the placement of a workpiece was changed

Setup and Dispense Command Icons

Click the dispense and setup command icons to enter the associated command at a numbered address in a program. Use the green arrows to move up and down through the icons Refer to “Appendix A, Command Function Reference” on page 80 for detailed information on all commands.

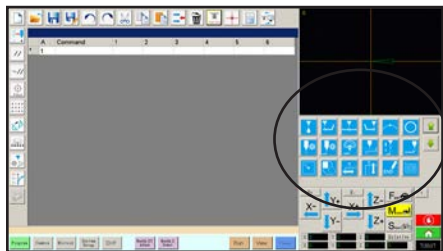

Icon Name	Icon	Function
Dispense Dot		Registers the current location as a Dispense Dot point
Line Start		Registers the current location as a Line Start point
Line Passing		Registers the current location as a Line Passing point
Line End		Registers the current location as a Line End point
Arc Point		Registers the current location as an Arc Point
Circle		Registers the current location as a Circle
Dispense Dot Setup		Sets Dispense Dot parameters
Line Dispense Setup		Sets line dispensing parameters
Line Speed		Sets a line speed (overrides the default speed settings)
Z Clearance Setup		Sets the Z clearance (overrides the default Z clearance setting)
Dispense End Setup		Sets how fast and how high the tip raises after dispensing
Backtrack Setup		Sets how the tip backtracks after dispensing
Find Mark		Registers a Find Mark
Fiducial Mark		Registers a Fiducial Mark (two required)
Step & Repeat X		Sets up Step & Repeat X parameters
Step & Repeat Y		Sets up Step & Repeat Y parameters

Icon Name	Icon	Function
End Program		Ends a program
Fill Area		Fills an area according to the Fill Area parameter settings
Label		Registers a label for a specific location in a program
Acceleration		Changes how the robot accelerates from point to point or along a continuous path
Output		Sends a selected output signal from the robot
Input		Tells the robot to check for an input signal from a selected input channel
Dispenser On		Enables dispensing
Dispenser Off		Disables dispensing
Initialize		Resets stored correction data
Dummy Point		Registers the current location as a Dummy Point
Wait Point		Registers the current location as a Wait Point
Park Position		Sends the robot to the park position
Stop Point		Registers the current location as a Stop Point
Goto Address		Skips to the specified address number in a program
Goto Label		Skips to the specified Label in a program

Navigation and Jogging Window

Use the icons on the navigation and jogging window to move the dispensing tip. Click the 1 button to change the window to an alternate view that allows you to change the jog speed values. These windows also include an actual time / cycle time display, a dispense actuation counter, and coordinate value displays.

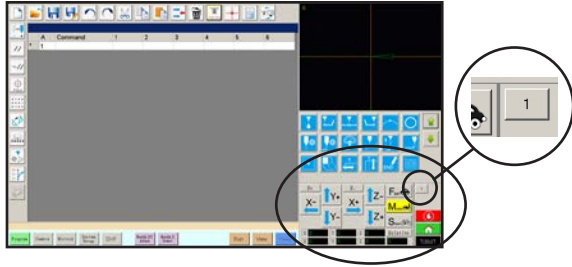

View 1 of the navigation and jogging window

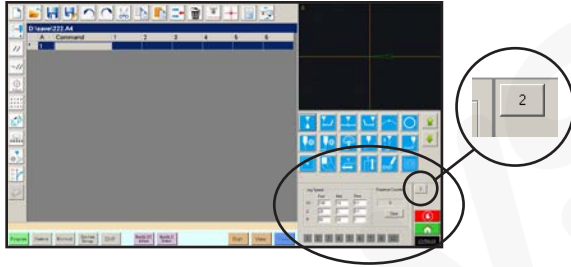

View 2 of the navigation and jogging window

View 1

Icon Name	Icon	Function
X+		Jogs the X axis to the right
X-		Jogs the X axis to the left
Y+		Jogs the Y axis backward (moves the fixture plate forward)
Y-		Jogs the Y axis forward (moves the fixture plate backward)
Z+		Jogs the Z axis down
Z-		Jogs the Z axis up
R+		Jogs the Z axis clockwise.
R-		Jogs the Z axis counterclockwise.
Fast		Fastest jogging speed
Middle		Medium jogging speed
Slow		Slowest jogging speed
Relative		Sets the origin relative to the coordinates of the workpiece. Coordinates are displayed under this button.
Jog button toggle		Toggles the navigation and jogging window between view 1 and view 2

View 2

Field	Screen Area	Function
Jog Speed		Allows you to change the jog speed settings by entering values using the keyboard.
Dispense Counter		Shows how many dispense actuations have occurred. Click CLEAR to reset the counter to zero (0).
Input / output triggers		Allows you to trigger a connected input / output by clicking the input / output number.

Both Views

Icon Name	Icon	Function
Stop		Stops the robot
Home		Sends the robot to the home position (0,0,0)
Counter		Shows the time for the time zone selected in the DispenseMotion controller's operating system OR shows the cycle time of the program (click the box to toggle the display)

System Setup Screen

Click the System Setup tab to go to the System Setup screen. This screen includes fields for system settings and provides access to the Robot Initial Setup wizard. Refer to the sections of the manual referenced below for detailed information on these fields.

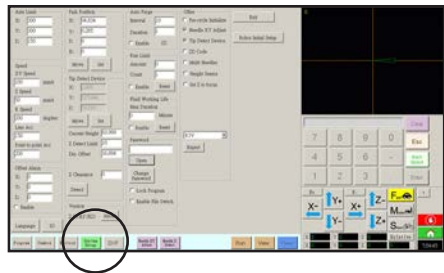

System Setup Screen Area	Function
Axis Limit	Refer to "Setting System Parameters" on page 36.
Speed	Refer to "Setting System Parameters" on page 36.
Line Acc Point to point Acc	Refer to "Setting System Parameters" on page 36.
Offset Alarm	Refer to "Setting System Parameters" on page 36.
Language	Refer to "Setting System Parameters" on page 36.
IO	Refer to "Setting Up Inputs / Outputs" on page 53.
Park Position	Refer to "Setting System Parameters" on page 36.
Tip Detect Device	Used only as needed for manual calibration of the tip-to-workpiece offset in place of using the Robot Initial Setup wizard. Refer to "Appendix B, Non-Wizard Setup Procedures" on page 97.
Version	Shows the current version of the software
Auto Purge	Refer to "How to Set Up Auto Purge, Program Cycle Limits, or Fluid Working Life Limits" on page 69.
Run Limit	
Fluid Working Life	
Password	Refer to "Setting Password Protection" on page 39.
Lock Program Enable File Switch	Refer to "How to Lock or Unlock a Program" on page 61.

System Setup Screen Area	Function
Pre-cycle Initialize	Causes the robot to move to the home position (0,0,0) before starting a dispense cycle.
Needle XY Detect	Enables or disables the Needle XY Adjust capability. When Needle XY Detect is checked, the Needle XY Adjust button appears on the Program screen.
Tip Detect Device	Specifies whether a tip detection device present. When Tip Detect Device is checked, the Needle XY Adjust button appears on the Program screen.
2D Code	Enables or disables QR code scanning capability.
Multi Needles	Enables or disables the multi-needles capability (used if the system includes more than one dispenser).
Height Sensor	Specifies whether the optional height sensor is installed.
Set Z to Focus	Specifies how the system captures Z values in command windows.
Model drop-down menu	Specifies the robot model.
Expert	For Nordson EFD use only.
Exit	Closes the software.
Robot Initial Setup	Opens the system setup and calibration wizard. Refer to "Setting Up and Calibrating the System (Required)" on page 40 for the system setup procedures.
Light	(If present) Refer to "Setting System Parameters" on page 36.

Camera Screen, Tab Bar, and Icons

Click the CAMERA tab to go to the Camera screen. The actual view of what the camera sees appears in the Primary View screen and the Mark Library appears in the Secondary View screen. The tabs at the top of the Camera screen are used for camera setup and mark creation.

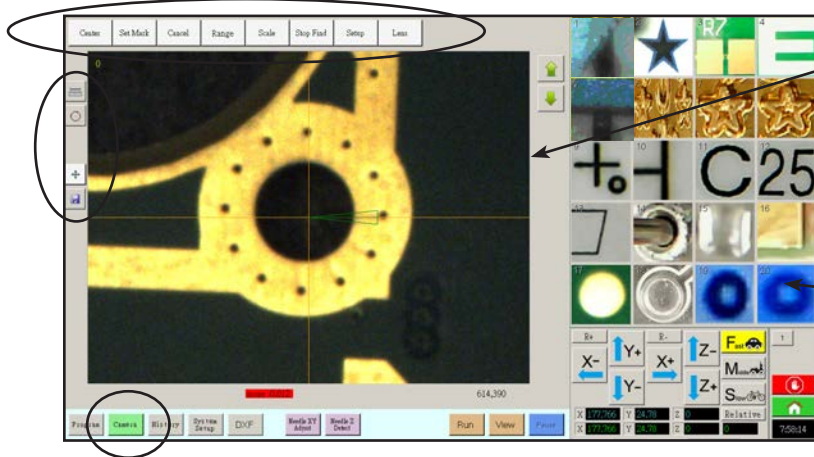

Primary View screen shows the actual camera view when the Camera tab is selected

Secondary View screen shows the Mark Library when the Camera tab is selected

Double-click any image to open the Template Match window. Refer to “Template Match and Area Windows” on page 34 for information about this window.

Camera Screen Tab	Function
Center	Moves the camera focal point to the center of an object
Set Mark	Sets a mark. Refer to “About Marks” on page 24 and to “How to Create a Mark” on page 66.
Cancel	Cancel the last camera-related action
Range	Sets the area within which the system searches for a mark
Scale	Scales the screen to match the camera view scale (occurs during setup).
Stop Find	Stops the attempt to find a mark
Setup	Opens the Camera Setup window that provides access to important setup fields related to the camera. Refer to “Camera Setup Screen” on page 35.
Lens	Adjusts the camera image quality to achieve the sharpest and most useful image.

Icon Name	Icon	Function
Measure Length		Measures the distance between two points. Refer to “How to Measure a Path or Circle on a Workpiece” on page 61.
Measure Circle Diameter		Measures the diameter of a circle. Refer to “How to Measure a Path or Circle on a Workpiece” on page 61.
Touch Move		When toggled, moves the camera to the point clicked and moves the focal point to the center of the viewing screen
Save		Saves the displayed camera image as a bitmap (*.bmp) file.

Template Match and Area Windows

Once a mark is stored in the Mark Library, you can double-click the mark image cell to open the Template Match window. The Template Match window provides access to the Area window, which is used to fine-tune how the camera evaluates a mark.

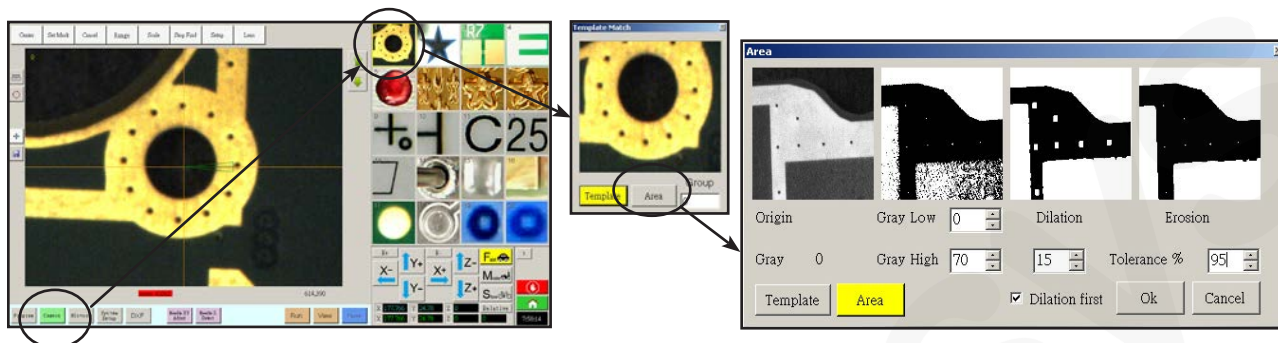

Template Match Area Window Section		Function
Origin	Origin	Displays the open mark image.
Gray	Gray 0	Displays the gray rating for the selected point in the origin image. When a point is selected, the value changes to reflect the gray level at that point. Knowing this value makes it easier to determine the best Gray Low and Gray High values to set.
Gray Low	Gray Low 0	Adjusts the gray low-tolerance value. The lower the value, the more white is tolerated in the image. The higher the value, the less white is tolerated in the image. NOTE: Gray Low values are typically lower than Gray High values. Range: 0–255
Gray High	Gray High 70	Adjusts the gray high-tolerance value. The lower the value, the less white is tolerated in the image. The higher the value, the more white is tolerated in the image. NOTE: Gray High values are typically higher than Gray Low values. Range: 0–255
Dilation	Dilation	Displays how the image appears after the Dilation calculation.
Dilation First counter	15 <input checked="" type="checkbox"/> Dilation first	When Dilation First is checked, the counter above the Dilation First checkbox controls the zoom of the image. When Dilation First is unchecked, the counter controls how much of the non-gray areas in the image are ignored. Range: 0–20
Dilation First checkbox		Sets the order in which the dilation and erosion calculations are performed. If the Dilation First checkbox is checked, the system performs the dilation calculation first. If the checkbox is unchecked, the system performs the erosion calculation first. When Dilation First is unchecked, the Dilation and Erosion labels switch places.
Erosion	Erosion	The image above Erosion shows how much white is filtered from the image.
Tolerance	Tolerance % 95	Sets the tolerance for how similar other mark images can be to the selected image, allowing the system to eliminate similar marks.

Camera Setup Screen

Click the CAMERA SETUP tab to see the Camera setup fields. The actual view of what the camera sees appears in the Primary View screen and the camera setup fields appear in the Secondary View screen.

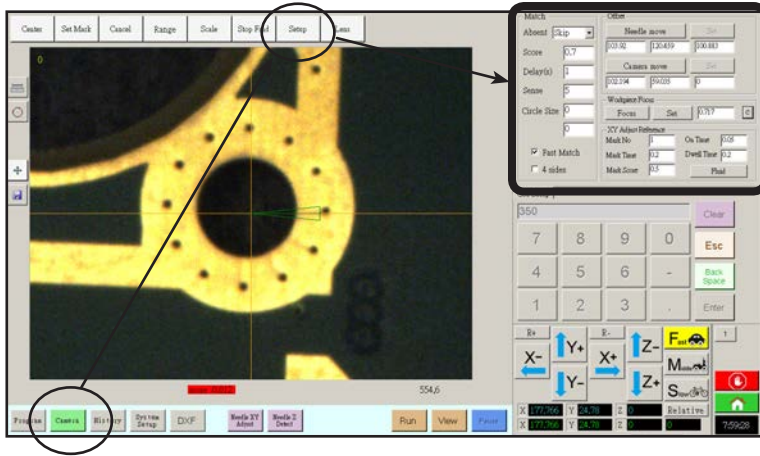

Camera Screen Setup Window Section	Function
Match	Affects how the camera searches for marks. Refer to “Setting How the System Finds Marks (Optional)” on page 54.
Offset	Used only as needed for manual calibration of the tip-to-camera offset in place of using the Robot Initial Setup wizard. Refer to “Appendix B, Non-Wizard Setup Procedures” on page 97.

Keypad

A numeric keypad appears when data entry fields are present. Use the keypad for mouse-click entry of numbers as an alternative to using the numbers on the keyboard. Regardless of how numbers are entered, you must click Enter on the keypad to the system to accept the input.

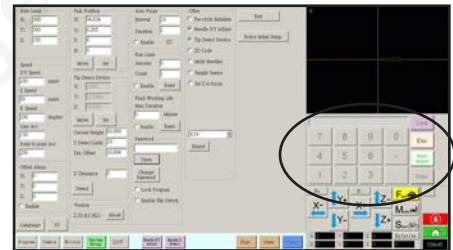

Setup

After installation and before creating any programs, perform these required and optional setup procedures as applicable for your automated dispensing system.

Setting System Parameters



The factory system settings are appropriate for most applications. Use this procedure as needed to view or change system settings. Important system settings include the following:

- **Speed:** The speed at which the dispensing tip moves.
- **Line Acc:** How the robot accelerates from one point to another.

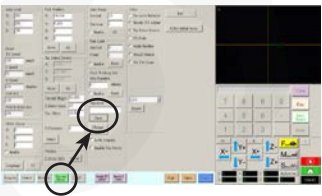
To View or Change System Parameters

#	Click	Step	Reference Image
1		<ul style="list-style-type: none"> • Click the SYSTEM SETUP tab, then click OPEN. 	
2		<ul style="list-style-type: none"> • View or change parameters as appropriate for your application. Refer to “System Setup Screen Fields” below for information on system-level parameters. 	
3		<ul style="list-style-type: none"> • Click another tab to close the System Setup screen. <p>NOTE: Settings are automatically saved except for the Model and Language selections. Changes to these selections take effect after you EXIT and reopen the DispenseMotion software.</p>	

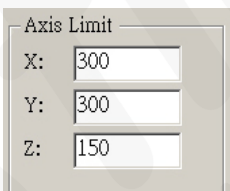
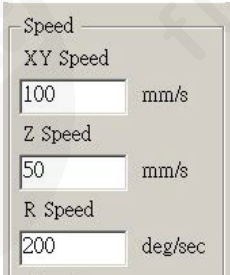



System Setup Screen Fields

Item	Screen Capture	Description
Axis Limit		Sets the range limits within which the robot can move. A value higher than the default settings (shown in the screen capture) cannot be entered.
Speed		<p>Sets the speed (in mm/s) of the axis movement. The default values are shown in the screen capture. For maximum speed specifications, refer to “Specifications” on page 12.</p> <p>NOTE: You can also change the jog speed settings by clicking the 2 next to the navigation and jogging window. Refer to “Navigation and Jogging Window” on page 31 for detailed information.</p>
		 CAUTION
		The robot automatically adjusts its speed depending on the complexity of the pattern. Forcing the robot to run at higher speeds can compromise accuracy and may disrupt system operation.

Continued on next page

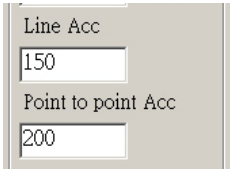
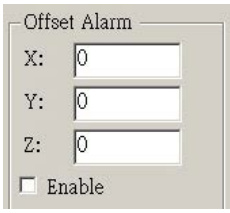
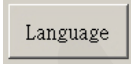
Setting System Parameters (continued)

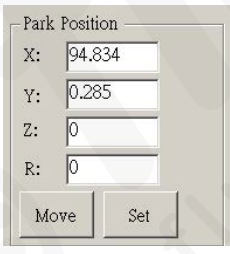
System Setup Screen Fields (continued)

Item	Screen Capture	Description
Line Acc Point to point Acc		<p>Sets the rate of acceleration for line dispensing (Line Acc) or from point to point (Point to point Acc):</p> <ul style="list-style-type: none"> • Line Acc is the dispensing speed within a line command, between the start- to mid-points, the start- to end-points, and the mid- to mid-points or mid- to end-points. • Point to point Acc is the robot movement speed between two dispense points. <p>Default: 200 Range: 20–500</p> <p>NOTE: The higher the acceleration, the faster a program runs. However, higher acceleration settings can also compromise pattern quality.</p> <p style="text-align: center;">⚠ CAUTION</p> <p>The robot automatically adjusts its speed depending on the complexity of the pattern. Forcing the robot to run at higher speeds can compromise accuracy and may disrupt system operation.</p>
Offset Alarm		<p>Sets how much deviation the system allows for offsets. The default settings are shown in the screen capture.</p> <p>EXAMPLE: If Offset Alarm is enabled and the result of an automatic offset performed by clicking Needle Z Detect or Needle XY Adjust is outside the XYZR values specified for Offset Alarm, the system displays an alarm.</p>
Language		Sets the user interface language. Any change takes effect upon system restart.
IO		Refer to “Setting Up Inputs / Outputs” on page 53.
Park Position		<p>Sets the position to which the dispensing tip moves to (1) purge fluid or (2) when the Park Position command occurs in a program.</p> <p>Click MOVE to move the tip to the displayed coordinates set for Park Position. To change the setting, jog the tip to the new location, then click SET to set the location as the new Park Position.</p>
Tip Detect Device		Used only as needed for manual calibration of the tip-to-workpiece offset in place of using the Robot Initial Setup wizard. Refer to “Appendix B, Non-Wizard Setup Procedures” on page 97.

Continued on next page

Setting System Parameters (continued)

System Setup Screen Fields (continued)

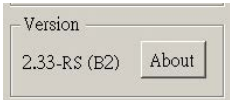
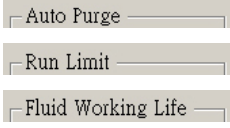
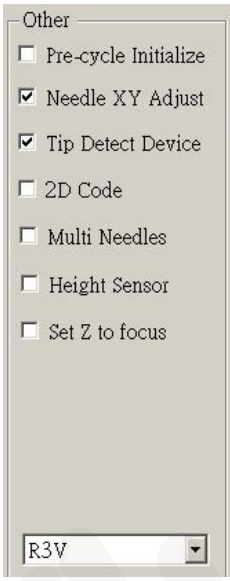
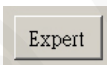
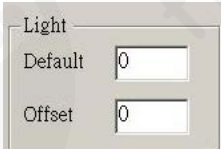
Item	Screen Capture	Description
Version		Shows the current version of the software.
Auto Purge Run Limit Fluid Working Life		To set up automatic purge settings, run limits, or fluid working life limits for a program, refer to “How to Set Up Auto Purge, Program Cycle Limits, or Fluid Working Life Limits” on page 69.
Other		<ul style="list-style-type: none"> • Pre-cycle Initialize: If checked, the robot always moves to the home position (0,0,0) before the start of a dispense cycle. • Needle XY Adjust: Enables or disables the Needle XY Adjust capability. When Needle XY Detect is checked, the Needle XY Adjust button appears on the Program screen and the capability is enabled in the Robot Initial Setup wizard. If unchecked, the capability is disabled in the Robot Initial Setup wizard. • Tip Detect Device: Indicates that the system includes the optional tip detector or tip alignment kit. When Tip Detect Device is checked, the Needle XY Adjust button appears on the Program screen and the capability is enabled in the Robot Initial Setup wizard. If unchecked, the capability is disabled in the Robot Initial Setup wizard. • 2D Code: Check this box to enable or disable QR code scanning capability. Refer to “Appendix D, QR Code Scanning Setup” on page 105 to set up QR code scanning. • Multi Needles: To dispense using more than one dispenser (up to 5 dispensers possible), check this box. Refer to “Appendix E, Multi-Needle Setup and Use” on page 108 to set up a multi-dispenser system. • Height Sensor: Not currently available. • Set Z to Focus: Sets whether the system captures the current Z height value in command windows. For RV systems, uncheck this box. • Model drop-down menu: Sets the dispensing software configuration; this setting must match the system configuration (model).
Expert		For Nordson EFD use only.
Light (if present)		<ul style="list-style-type: none"> • Default: Allows you to control the light intensity if an external switch is used to control the light. • Offset: When the system is in the CCD Mode, automatically changes the light intensity based on the value entered. <p>NOTE: The Light settings are present only if an optional light accessory is installed.</p>

Setting Password Protection

Use the Password portion of the System Setup screen to set or reset a password. The purpose of a password is to protect the system settings from unauthorized editing.

NOTES:

- The default is no password protection.
- If the password is forgotten, contact your Nordson EFD representative for assistance.
- A password is limited to 16 numbers or characters.

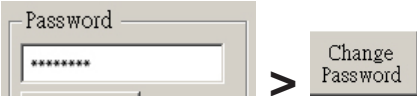
#	Click	Step
1		<ul style="list-style-type: none"> • Click SYSTEM SETUP > OPEN.
2		<ul style="list-style-type: none"> • Under Password, enter a password or make the field blank to remove a password, then click CHANGE PASSWORD. <p>The system confirms the password change, which takes effect after the software is closed and then reopened:</p> <ul style="list-style-type: none"> - If a password was entered, the system will prompt for the password before opening the System Setup screen. - If the Password field was blank, no password will be required to open the System Setup screen.

Setting Up and Calibrating the System (Required)

Before creating any programs or using the automatic offset update capabilities of the system, you must properly set up and calibrate the system. Correct system setup and calibration are critical for proper system operation.

The Robot Initial Setup wizard guides you through the complete setup and calibration process. This process must be performed at initial startup and also after any change to the system.

Examples of system changes include the following:

- Any time a component installed on the Z axis (such as the syringe barrel or camera) is moved.
- Any time a dispensing tip or nozzle is changed.

Setup and calibration includes the following tasks:

- Verifying the robot model, tip detection, and Set Z to Focus selections
- Setting the optional tip alignment kit selection (if applicable)
- Setting up the tip detector* or tip alignment device
- Verifying the 4-axis selection
- Opening the robot initial setup wizard and setting the angle of rotation
- Setting up tip detection and tool centering calibration
- Setting the camera-to-tip offset
- Setting a mark
- Setting the camera scale*
- Setting the tip-to-workpiece offset*
- Testing the system setup and calibration

All required setup and calibration tasks are guided by the Robot Initial Setup wizard. However, the tasks shown above with an asterisk () can be performed individually as needed. Refer to “Appendix B, Non-Wizard Setup Procedures” on page 97 for the procedures.

NOTE: Refer to “About Offsets” on page 23 for an explanation of offsets.

Verifying the Robot Model, Tip Detection, and Set Z to Focus Selections

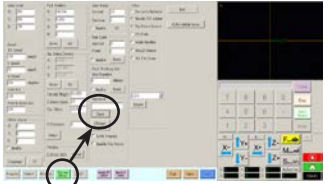
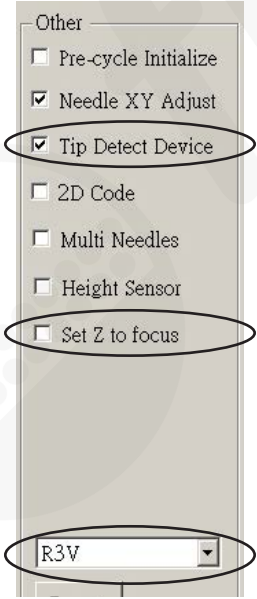
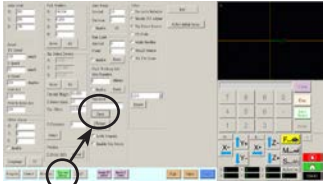





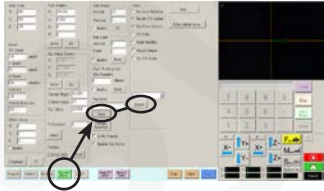

#	Click	Step	Reference Image
1		<ul style="list-style-type: none"> • Click SYSTEM SETUP > OPEN. 	
2		<ul style="list-style-type: none"> • Under Other, verify the following: <ul style="list-style-type: none"> - If your system includes a tip detector or tip alignment kit, Tip Detect Device is checked. - Set Z to Focus is unchecked (not checked). - The correct robot model is shown. If the robot model is not correct, go to “Changing the Robot Model Selection” on page 52 to select the correct model. Return here to continue. • If you made changes, close and reopen the DispenseMotion software for the changes to take effect. 	
3		<ul style="list-style-type: none"> • Continue to “Setting the Optional Tip Alignment Kit Selection” on page 41. 	

Setting Up and Calibrating the System (Required) (continued)

Setting the Optional Tip Alignment Kit Selection

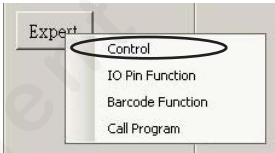

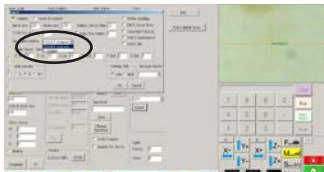





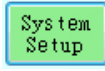

IMPORTANT: If your system includes the optional tip detector, skip to the next procedure.

If you installed the optional tip alignment kit, follow this procedure to specify the kit in the Expert window. A tip alignment kit allows tip-to-workpiece offset setup, or tip height calibration, without the need for the tip to physically touch the sensor. Refer to “Accessories” on page 73 for the optional tip alignment kit part number.

#	Click	Step	Reference Image
1		<ul style="list-style-type: none"> Click SYSTEM SETUP > OPEN > EXPERT. 	
2		<ul style="list-style-type: none"> Enter 11111111, then click OK. 	
3		<ul style="list-style-type: none"> Click EXPERT, then click CONTROL. 	
4		<ul style="list-style-type: none"> In the Expert window, select R ALIGNER. Click OK to save the setting, then click OK again to confirm. 	
5		<ul style="list-style-type: none"> Click EXIT to close, then reopen the DispenseMotion software for the change to take effect. 	
6		<ul style="list-style-type: none"> Continue to “Verifying the 4-Axis Selection” on page 42. 	

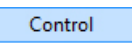
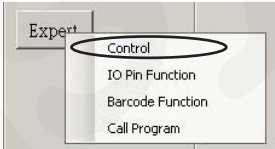
Setting Up and Calibrating the System (Required) (continued)

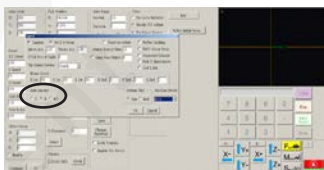
Verifying the 4-Axis Selection

#	Click	Step	Reference Image
1	 >  > 	<ul style="list-style-type: none"> Click SYSTEM SETUP > OPEN > EXPERT. 	
2	11111111 > 	<ul style="list-style-type: none"> Enter 11111111, then click OK. 	
3	 > 	<ul style="list-style-type: none"> Click EXPERT, then click CONTROL. 	
4		<ul style="list-style-type: none"> In the Expert window, select 4 under AXIS AMOUNT. Click OK to save the setting, then click OK again to confirm. 	
5		<ul style="list-style-type: none"> Click EXIT to close, then reopen the DispenseMotion software for the change to take effect. 	
6		<ul style="list-style-type: none"> Continue to “Setting Up the System Using the Robot Initial Setup Wizard” on page 43. 	







Setting Up and Calibrating the System (Required) (continued)

Setting Up the System Using the Robot Initial Setup Wizard

The Robot Initial Setup wizard guides you through all the steps required to properly set up the system, including the calibration and setting of offsets.

Important: The tip will not rotate, either virtually or physically, until the tool centering calibration portion (Step 1) of the Robot Initial Setup wizard has been performed.

Opening the Robot Initial Setup Wizard and Setting the Angle of Rotation

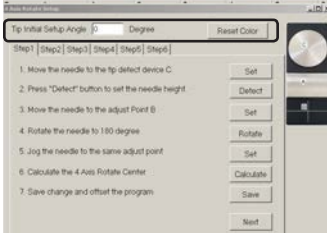
#	Click	Step	Reference Image
1		<ul style="list-style-type: none"> Click SYSTEM SETUP > OPEN. 	
2		<ul style="list-style-type: none"> Click ROBOT INITIAL SETUP. <p>The Robot Initial Setup wizard opens.</p> <p>NOTE: If the optional tip detector or tip alignment kit was installed, the wizard shows an image of the applicable device.</p> <ul style="list-style-type: none"> Perform the actions on tabs 1–6 one at a time. The actions are also provided in this manual for your reference as needed. <p>NOTE: The wizard buttons change to the color blue when clicked. To restart the wizard without closing it, click RESET COLOR to return all selections to their default state.</p>	 <p><i>Robot Initial Setup wizard showing the optional tip detector</i></p>  <p><i>Robot Initial Setup wizard showing the optional tip alignment kit</i></p>
3		<ul style="list-style-type: none"> Enter the desired number of degrees for the Tip Initial Setup Angle. <p>The green arrow on the screen changes based on the entered value. Refer to “Example of the how the green arrow changes based on the value entered for Tip Initial Setup Angle” on page 44 for images.</p> <p>NOTE: Ensure that the angle does not cause the dispensing device to obscure the camera view.</p>	
4		<ul style="list-style-type: none"> Continue to “Robot Initial Setup (Step 1 Tab): Setting Up Tip Detection and Tool Centering Calibration” on page 44. 	

Setting Up the System Using the Robot Initial Setup Wizard (continued)

Opening the Robot Initial Setup Wizard and Setting the Angle of Rotation (continued)

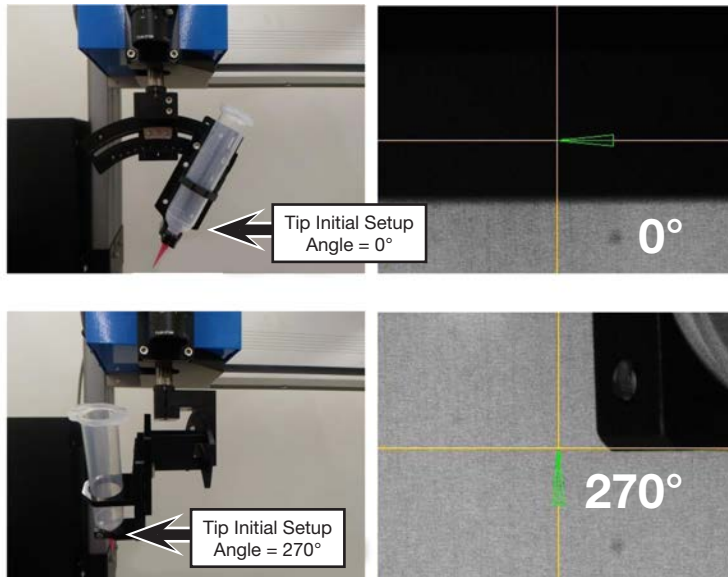

Example of the how the green arrow changes based on the value entered for Tip Initial Setup Angle

Robot Initial Setup (Step 1 Tab): Setting Up Tip Detection and Tool Centering Calibration



Important: The tip will not rotate, either virtually or physically, until the tool centering calibration is done.

#	Click	Step	Reference Image	
1		<ul style="list-style-type: none"> If your system does not include the optional tip detector or tip alignment kit, create a crosshair target. Jog the tip until it is positioned about 2 mm above the following, as applicable for your system (see below for examples): <ul style="list-style-type: none"> The crosshair target you created The sensor on the optional tip detector The crosshairs on the optional tip alignment kit Click SET next to step 1. 		
		<p>Crosshair target created with a removable note</p>	<p>Sensor on the optional tip detector</p>	<p>Crosshairs on the optional tip alignment kit</p>

Continued on next page

Setting Up the System Using the Robot Initial Setup Wizard (continued)

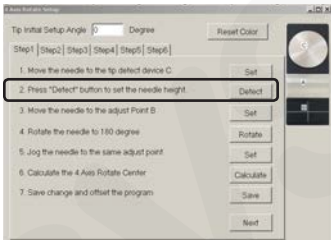
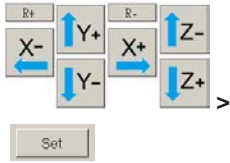
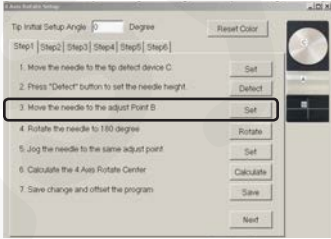
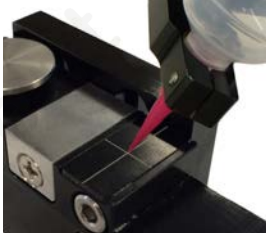

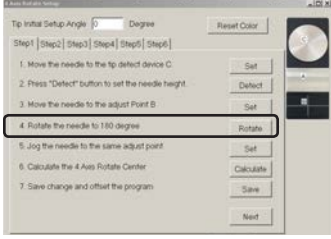
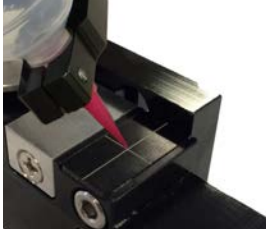
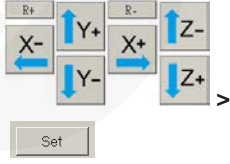
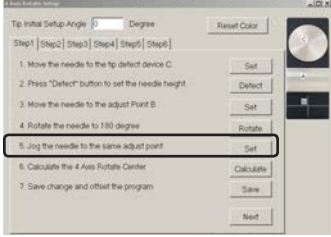
Robot Initial Setup (Step 1 Tab): Setting Up Tip Detection and Tool Centering Calibration (continued)

#	Click	Step	Reference Image
2		<ul style="list-style-type: none"> Click DETECT. <p>The system performs the tip detection or alignment operation.</p>	
3		<ul style="list-style-type: none"> Jog the tip until it is positioned about 2 mm above the crosshairs on the tip detection device. <p>NOTE: The optional tip alignment kit is shown.</p> <ul style="list-style-type: none"> Click SET next to step 3. 	 
4		<ul style="list-style-type: none"> Click ROTATE next to step 3. The tip rotates 180°. 	 
5		<ul style="list-style-type: none"> Jog the tip to the same calibration point used in step 3. Click SET. 	

Continued on next page



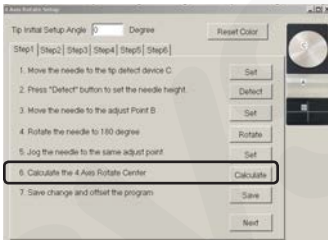

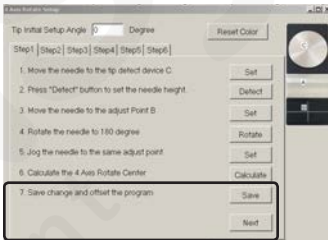

Setting Up the System Using the Robot Initial Setup Wizard (continued)

Robot Initial Setup (Step 1 Tab): Setting Up Tip Detection and Tool Centering Calibration (continued)

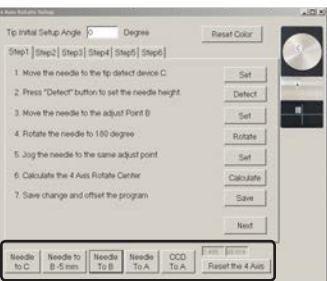
#	Click	Step	Reference Image
6		<ul style="list-style-type: none"> Click CALCULATE. <p>The system performs the tool centering calibration. This calibration ensures that the tip stays centered over the same point while rotation occurs, even as the X and Y axes adjust the location of the workpiece.</p> <p>NOTE: To test the setup, use the buttons at the bottom of the wizard. Refer to “Function of the Test-Move Buttons in the Robot Initial Setup Wizard” below for detailed information.</p>	
7	 > 	<ul style="list-style-type: none"> Click SAVE. Click NEXT. 	
8		<ul style="list-style-type: none"> Continue to “Robot Initial Setup (Step 2 Tab): Setting the Camera-to-Tip Offset” on page 47. 	







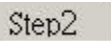
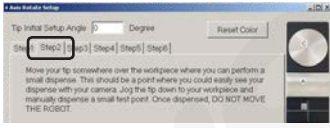
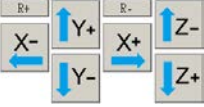
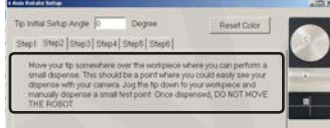

Function of the Test-Move Buttons in the Robot Initial Setup Wizard

Use the buttons at the bottom of the Robot Initial Setup window to verify settings at any time during the setup process.

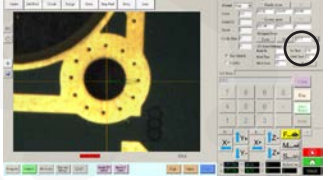
Button	Function	Reference Image
Needle to C 	Moves the tip to the calibration point that was 2 mm above the tip detection device.	
Needle to B-5 mm 	Moves the tip to 5 mm above the point used for the tool centering calibration.	
Needle to B 	Moves the tip to the point used for the tool centering calibration.	
Needle to A 	Moves the tip to the test deposit location.	
CCD to A 	Centers the camera over the test deposit location.	
Reset the 4 Axis 	Resets the tool centering calibration calculation.	

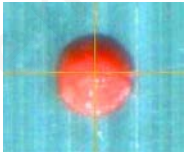

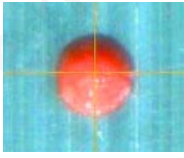
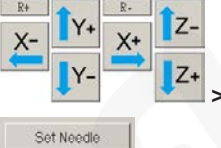
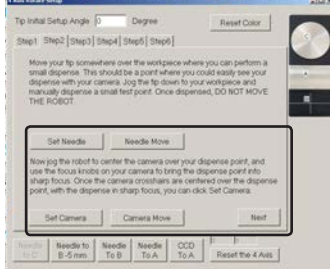
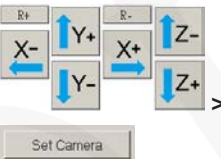

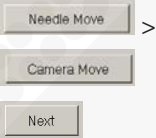







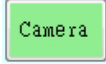
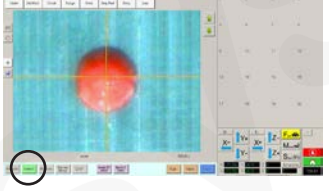

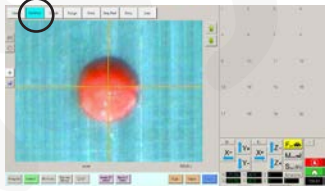
Setting Up the System Using the Robot Initial Setup Wizard (continued)

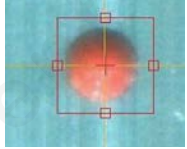
Robot Initial Setup (Step 2 Tab): Setting the Camera-to-Tip Offset

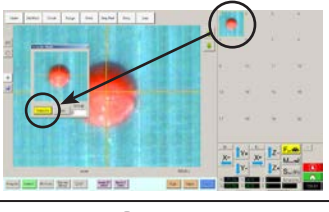
#	Click	Step	Reference Image
1		<ul style="list-style-type: none"> Ensure that the STEP2 tab is open. 	
2		<ul style="list-style-type: none"> Jog the tip to a good location on the work surface to deposit a test dot of fluid. 	
3		<ul style="list-style-type: none"> Click the CAMERA tab and then click SETUP at the top of the Camera screen. <p>You will use the fields under XY Adjust Reference to deposit a test dot of fluid.</p>	
4		<ul style="list-style-type: none"> Use the keypad to enter the following recommended dispense dot parameters: <ul style="list-style-type: none"> - ON TIME: 0.5 - DWELL TIME: 0.2 	 
5		<ul style="list-style-type: none"> Click FLUID to dispense a dot of fluid. 	
6		<ul style="list-style-type: none"> Jog the tip until it is positioned about 2 mm above the dispense dot. Click SET NEEDLE. 	
7		<ul style="list-style-type: none"> Jog the camera until the camera crosshairs are centered over the dispense dot. Focus the camera until the image of the dispense dot is clear. Refer to “Camera” on page 16 as needed for instructions on focusing the camera. Click SET CAMERA. 	
8		<ul style="list-style-type: none"> Click NEEDLE MOVE to test the setup. <p>The system should deposit a dispense dot at the same dispense location used for step 5.</p> <ul style="list-style-type: none"> Click CAMERA MOVE to further test the setup. <p>The camera should center its crosshairs over the test dot dispensed in step 5.</p> <ul style="list-style-type: none"> Click NEXT. 	
9		<ul style="list-style-type: none"> Continue to “Robot Initial Setup (Step 3 Tab): Setting a Mark” on page 48. 	

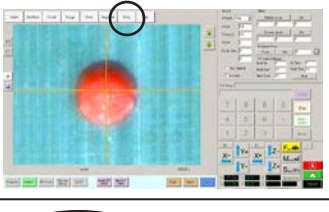

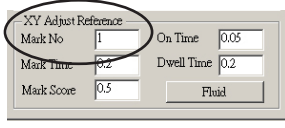





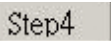

Setting Up the System Using the Robot Initial Setup Wizard (continued)

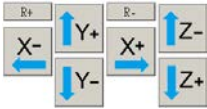
Robot Initial Setup (Step 3 Tab): Setting a Mark

#	Click	Step	Reference Image
1		<ul style="list-style-type: none"> Ensure that the STEP3 tab is open. 	
2		<ul style="list-style-type: none"> Click the CAMERA tab. <p>The actual camera view appears in the Primary View screen and the Mark Library appears in the Secondary View screen.</p>	
3		<ul style="list-style-type: none"> Click SET MARK. <p>A red box appears.</p>	
4		<ul style="list-style-type: none"> Click and hold the center of the red box, drag it over the dispense dot, and then click and drag the four box handles such that they outline the dot. 	
5		<ul style="list-style-type: none"> Click a socket in the Mark Library to save the mark as a Mark No., then click TEMPLATE when the Template Match window appears. <p>The system saves the image in the Mark Library.</p> <p>NOTE: Be sure to remember the Mark No.</p>	
6		<ul style="list-style-type: none"> Click SETUP to go back to the Camera window Offset fields. 	
7		<ul style="list-style-type: none"> Use the keypad to enter the Mark number in the Mark No field under XY Adjust Reference. <p>NOTES:</p> <ul style="list-style-type: none"> Make sure you click ENTER on the keypad to enter the Mark number. Mark Time sets the time allowed for the system to find the mark. 	
8		<ul style="list-style-type: none"> Click NEXT. 	
9		<ul style="list-style-type: none"> Continue to “Robot Initial Setup (Step 4 Tab): Setting the Camera Scale” on page 49. 	

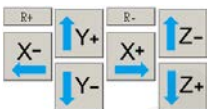

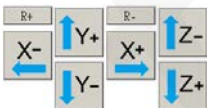
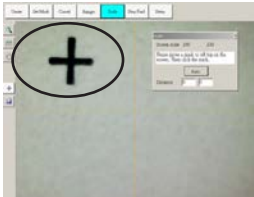
Setting Up the System Using the Robot Initial Setup Wizard (continued)

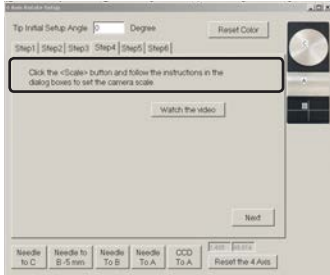
Robot Initial Setup (Step 4 Tab): Setting the Camera Scale

#	Click	Step	Reference Image
1		<ul style="list-style-type: none"> Ensure that the STEP4 tab is open. 	
2		<ul style="list-style-type: none"> Click the CAMERA tab. 	
3		<ul style="list-style-type: none"> Jog the camera to a point of reference that is located on the lower right corner of the workpiece. Bring the reference point into focus. Refer to “Camera” on page 16 as needed for instructions on focusing the camera. 	
4	 > 	<ul style="list-style-type: none"> Click the CAMERA tab and then click SCALE. <p>The Scale window opens.</p> <p>NOTE: When the camera views an object, it converts the pixels to a true measurement. For the camera to make this conversion accurately, you must “teach” the camera what the size of an object is in comparison to pixels per inch by setting the camera scale.</p>	
5		<ul style="list-style-type: none"> Choose a point of reference on the workpiece and jog the camera so that the reference point is located in the lower right quadrant of the camera screen, then click the point. 	
6		<ul style="list-style-type: none"> Jog the camera again until the same reference point is located in the upper left quadrant of the camera screen, then click the point. <p>The camera scale is now set.</p>	
7		<ul style="list-style-type: none"> Click NEXT. 	
8		<ul style="list-style-type: none"> Continue to “Robot Initial Setup (Step 5 Tab): Setting the Tip-to-Workpiece Offset” on page 50. 	



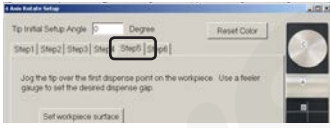
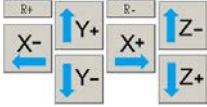
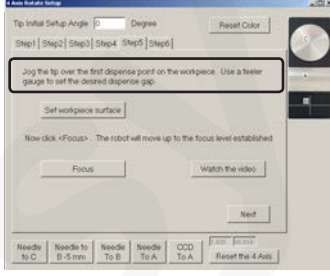
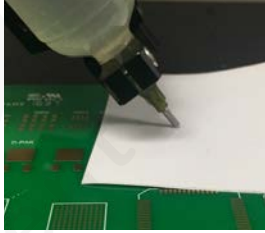

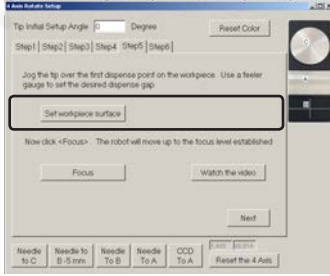
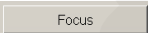
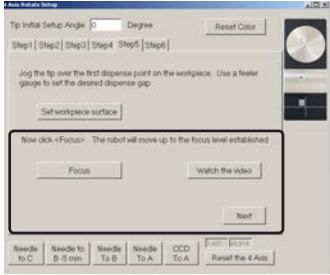

Setting Up the System Using the Robot Initial Setup Wizard (continued)

Robot Initial Setup (Step 5 Tab): Setting the Tip-to-Workpiece Offset

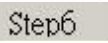
#	Click	Step	Reference Image
1		<ul style="list-style-type: none"> Ensure that the STEP5 tab is open. 	
2		<ul style="list-style-type: none"> Jog the tip to a good reference point on the workpiece. Jog the tip down until it is as close to the workpiece as possible without touching the surface. 	
3		<ul style="list-style-type: none"> Using a feeler gauge, set the desired distance between the bottom of the tip and the workpiece. 	
4		<ul style="list-style-type: none"> Click SET WORKPIECE SURFACE. 	
5		<ul style="list-style-type: none"> Click FOCUS. The tip moves to the correct focus height. Click NEXT. 	
6		<ul style="list-style-type: none"> Continue to "Robot Initial Setup (Step 6 Tab): Testing the System Setup and Calibration" on page 51. 	

Setting Up the System Using the Robot Initial Setup Wizard (continued)

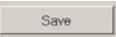
Robot Initial Setup (Step 6 Tab): Testing the System Setup and Calibration

#	Click	Step	Reference Image
1		<ul style="list-style-type: none"> Ensure that the STEP6 tab is open. 	
2		<ul style="list-style-type: none"> Click NEEDLE Z DETECT to test the setup. Click YES/OK when prompted for confirmations. <p>NOTES:</p> <ul style="list-style-type: none"> When the system performs a Needle Z Detect, it automatically performs a Needle XY Adjust directly after performing the Needle Z Detect. Refer to “How the System Responds to Needle Z Detect or Needle XY Adjust” on page 52 for a detailed description of the system response to a Needle Z Detect selection. 	
3	 > 	<ul style="list-style-type: none"> Click SAVE. Click FINISH. 	

The system is now properly set up and calibrated. Refer to “Programming” on page 56 to create programs.

How the System Responds to Needle Z Detect or Needle XY Adjust

NOTE: On systems with the optional tip detector or tip alignment kit, both the Needle XY Adjust and Needle Z Detect buttons are present. On systems without these devices, only the Needle XY Adjust button is present.

When you click NEEDLE Z DETECT, the system performs the following actions:







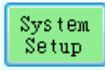

- Moves the dispensing tip over the Tip Detector sensor and lowers it until it touches the sensor.
- Measures and compares the difference between the last measurement and the current measurement.
- Requests confirmation for any change in the tip-to-workpiece offset (Z clearance).
- Realigns all points in the currently open program to the new tip-to-workpiece offset (Z clearance).
- Automatically performs a Needle XY Adjust sequence (shown below).

When you click NEEDLE XY ADJUST, the system performs the following actions:

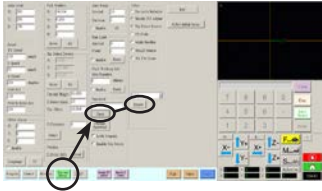
- Moves the dispensing tip to a preset location on the workpiece.
- Dispenses a dot of fluid.
- Moves the camera over the deposited dot of fluid.
- Compares the alignment of the dot with the mark image saved in the Mark Library.
- Requests confirmation for any change in the camera-to-tip offset (XY offsets).
- Realigns all points in the currently open program to the new XY offsets.

Changing the Robot Model Selection

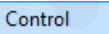
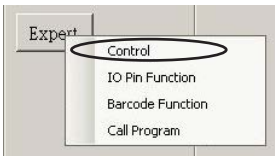
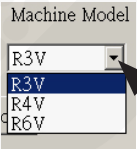
The correct robot model must be selected for the system to operate properly. Follow this procedure to change the robot model selection as needed.

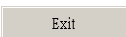
#	Click	Step	Reference Image
1	 >  > 	<ul style="list-style-type: none"> • Click SYSTEM SETUP > OPEN > EXPERT. 	
2	11111111 > 	<ul style="list-style-type: none"> • Enter 11111111, then click OK. 	
3	 > 	<ul style="list-style-type: none"> • Click EXPERT, then click CONTROL. 	
4		<ul style="list-style-type: none"> • Select the correct robot model from the Machine Model drop-down menu. 	
5		<ul style="list-style-type: none"> • Click EXIT to close, then reopen the DispenseMotion software for the change to take effect. 	

Setting Up Inputs / Outputs

If you connected inputs / outputs, follow this procedure to test input / output connections.

NOTE: All automated dispensing systems provide 8 standard inputs and 8 standard outputs. A kit to expand to 16 inputs and 16 outputs is available. Refer to “Accessories” on page 73.

PREREQUISITES

- ❑ The system is properly installed and set up. Refer to “Installation” on page 17 and “Setup” on page 36.
- ❑ Input / output wiring is properly connected. Refer to “I/O Port” on page 78 for wiring diagrams.

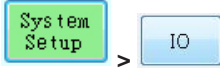
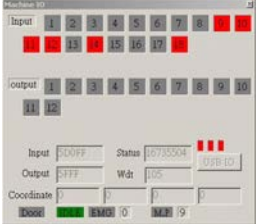
#	Click	Step
1		<ul style="list-style-type: none"> • Click SYSTEM SETUP > IO.
2		<ul style="list-style-type: none"> • Click the outputs you want turn ON or OFF, then click the X to close the window. <p>NOTES:</p> <ul style="list-style-type: none"> • Inputs flash red when they are turned ON. • Use only inputs / outputs 1 through 8. The remaining I/Os are reserved for the system.

Configuring Input / Outputs for a Special Purpose

The IO Pin Function feature provides a set of user-configurable conditions that affect the operation of the robot. Refer to “Appendix F, I/O Pin Function Setup” on page 113.

Setting How the System Finds Marks (Optional)



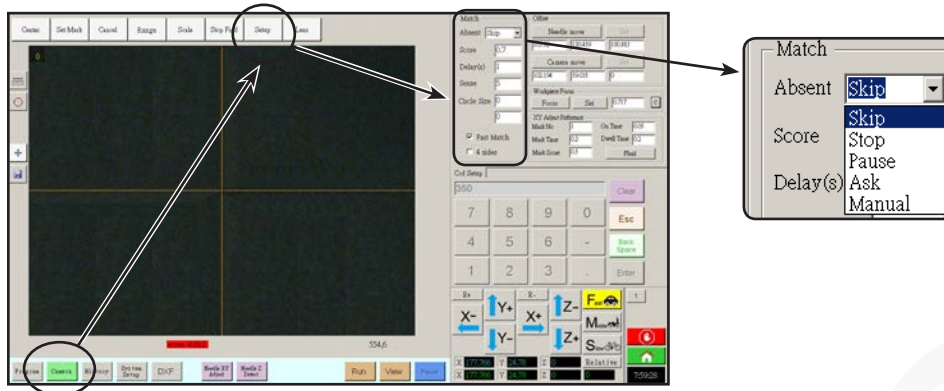





Use the fields under CAMERA > SETUP > MATCH to adjust how the system functions when it searches for marks.

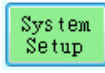

Item	Function	
Absent	Specifies how the system responds when it is unable to recognize a mark.	
	Parameter	Description
	Skip	The robot skips to the next program address.
	Stop	The robot stops.
	Pause	The robot pauses.
	Ask	The system asks if you want to: Find Again, Find Next, Stop Find, or use the Manual mode.
Manual	The system asks you to jog the camera to the next mark and then select PAUSE to continue the program. In this context, PAUSE means to skip the failure to recognize the mark and continue on.	
Score	Specifies how accurately the camera finds a mark based on a value from 0.1 to 1. A higher value results in more precise matching. A lower value results in less precise matching.	
Delay(s)	Sets how the long system delays (in seconds) searching for a mark when it reaches the mark area.	
Sense	Specifies how accurately the camera aligns with the pixels of a mark based on a value from 1 to 200. When the Sense value is low, the camera is slower to align with the mark because it repeatedly checks the position of the mark to achieve high accuracy. When the Sense value is higher, the camera aligns with the mark faster, but with less accuracy. For example, a Sense value of 1 means the deviation cannot be more than one pixel. When the Sense value is 200, the deviation can be up to 200 pixels. NOTE: For a slower find speed but better accuracy, enter lower Sense and Score values; for a faster find speed but less accuracy, enter higher Score and Sense values.	
Circle Size	Sets the size of the yellow and green circles on the Camera screen. A higher value results in a larger circle.	
Fast Match	If this box is checked, the camera searches for mark more quickly but with less accuracy.	
4 sides	Sets the area within which the camera searches for a mark. If 4 sides is NOT checked, the camera looks only within the specified range (set under Range). If 4 sides is checked, the camera overrides the range settings and performs a full-screen search for the mark. This increases the chances of finding the mark, but is slower.	

Setting the Units of Measure

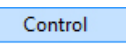
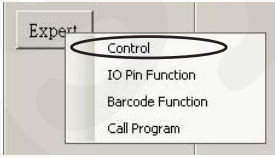
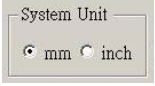
By default, the system displays units of measure using the metric system. Follow this procedure to change how the system displays units of measure.

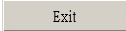
#	Click	Step	Reference Image
1	 >  > 	<ul style="list-style-type: none"> Click SYSTEM SETUP > OPEN > EXPERT. 	
2	11111111 > 	<ul style="list-style-type: none"> Enter 11111111, then click OK. 	
3	 > 	<ul style="list-style-type: none"> Click EXPERT, then click CONTROL. 	
4		<ul style="list-style-type: none"> In the Expert window, select the desired unit of measure under System Unit. Click OK to save the setting, then click OK again to confirm. 	
5		<ul style="list-style-type: none"> Click EXIT to close, then reopen the DispenseMotion software for the change to take effect. 	

Restoring the System to the Factory Default Settings

To restore all settings to their factory default values, open and then close the following file located on the C:\ drive: C:\ever_sr\Initial Setup.

Programming

This section provides how-to procedures for the most commonly performed programming tasks. Refer to “How to Create and Run a Program” on page 59 for an example of how to use the dispensing software to create a complete program. If you have difficulty creating a program for your application, contact your Nordson EFD representative. Before using this section:

- Complete all applicable installation tasks. Refer to “Installation” on page 17.
- Complete all required setup tasks. Refer to “Setup” on page 36.
- Refer to “Concepts” on page 22 for important robot programming concepts and for an overview of the dispensing software screens and icons.

How to Rotate the Tip and Set the Angle of Rotation

To set the angle of tip rotation, you must first rotate the tip to the desired position, then open the command window into which the value should be entered. You cannot directly enter the angle of tip rotation in a command window. Follow these procedures to rotate the tip and to set the angle of rotation for a command window.

IMPORTANT:

- The tip will not rotate, either virtually or physically, until the tool centering calibration portion of the Robot Initial Setup wizard has been performed. This calculation is Step 1 of the wizard.
- To physically rotate the dispense valve installed on the robot Z axis head, the system must be in the Tip mode. The dispense valve will not physically rotate if the system is in the CCD mode.
- You cannot set the rotation angle of the tip inside a command window. To enter the tip rotation angle in a command window, you must first rotate the tip to the desired position, then open a command window. The system automatically populates the R field with the current angle of rotation.

⚠ CAUTION

Failure to set the angle of tip rotation as described in this section will compromise the integrity of the dispense pattern. Set the desired angle of tip rotation before opening a command window.

DispenseMotion Screen Elements Used to Show Tip Rotation

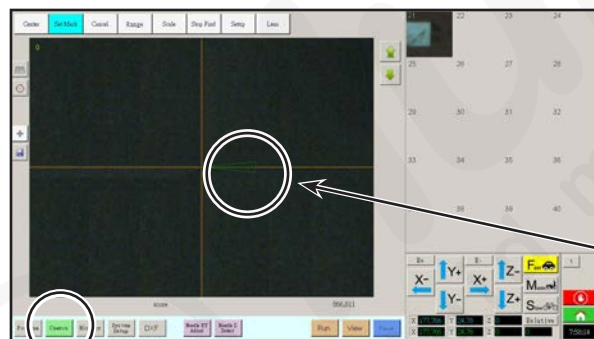

Camera tab selected

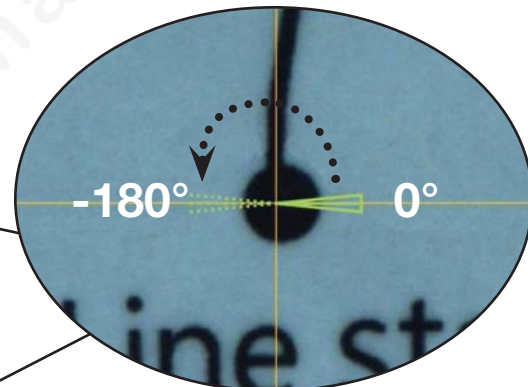

The green arrow on the camera screens shows the angle of tip rotation.

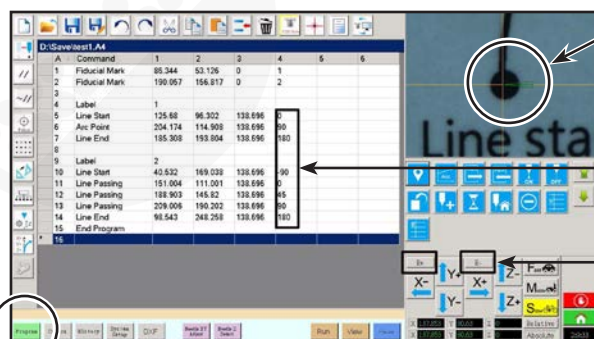

Program tab selected

Column 4 of the dispensing program shows the angle of tip rotation in degrees.

Use the R+ and R- keys to rotate the tip

How to Rotate the Tip and Set the Angle of Rotation (continued)

Setting the Tip Rotation Angle in the Tip Mode

Follow this procedure to physically rotate the tip to the desired angle of rotation.

Important: The tip will not rotate, either virtually or physically, until the tool centering calibration portion of the Robot Initial Setup wizard has been performed. This calculation is Step 1 of the wizard.

PREREQUISITES

- The system is properly set up. Refer to “Setting Up and Calibrating the System (Required)” on page 40.

#	Click	Step	Reference Image
1		<ul style="list-style-type: none"> Click the MODE icon to place the system in the Tip mode. <p>NOTE: When the system is in the Tip mode, the dispense valve and tip installed on the Z axis head will rotate; the green arrow on the camera view screen will also rotate.</p>	
2		<ul style="list-style-type: none"> Click R+ to rotate the tip clockwise. Click R- to rotate the tip counterclockwise. <p>Observe the dispense valve on the robot Z axis head to see the rotation, or</p> <p>observe the green arrow in the Secondary View screen to see the tip rotation.</p>	 
3		<ul style="list-style-type: none"> Double-click a command address line to open the command edit drop-down menu and then open the desired command. <p>The system automatically populates the R field with the current angle of rotation.</p> <p>In addition, the values in column 4 of the command address lines show the tip rotation angle. Refer to “DispenseMotion Screen Elements Used to Show Tip Rotation” on page 56 for an illustration.</p>	

How to Rotate the Tip and Set the Angle of Rotation (continued)





Setting the Tip Rotation Angle in the CCD Mode

Follow this procedure to rotate the tip virtually (not physically) to the desired angle of rotation by viewing the green arrow on the camera view screen.

Important: The tip will not rotate, either virtually or physically, until the tool centering calibration portion of the Robot Initial Setup wizard has been performed. This calculation is Step 1 of the wizard.

PREREQUISITES

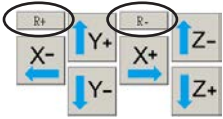
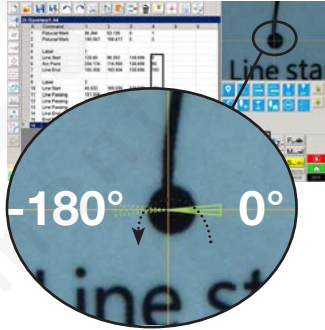
- The system is properly set up. Refer to “Setting Up and Calibrating the System (Required)” on page 40.

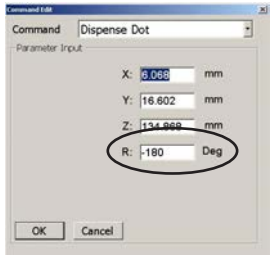





#	Click	Step	Reference Image
1		<ul style="list-style-type: none"> Click the MODE icon to place the system in the CCD mode. <p>NOTE: When the system is in the CCD mode, the dispensing valve installed on the Z axis head will NOT rotate.</p>	
2		<ul style="list-style-type: none"> Click R+ to rotate the tip clockwise. Click R- to rotate the tip counterclockwise. <p>Observe the green arrow on the Secondary View screen to see the tip rotation.</p>	
3		<ul style="list-style-type: none"> Double-click a command address line to open the command edit drop-down menu and then open the desired command. <p>The system automatically populates the R field with the current angle of rotation.</p> <p>In addition, the values in column 4 of the command address lines show the tip rotation angle. Refer to “DispenseMotion Screen Elements Used to Show Tip Rotation” on page 56 for an illustration.</p>	

How to Create and Run a Program

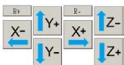
The procedure provides the basic steps for creating and running a program. Every program is different. Use these basic steps and refer to “How to Create Patterns” on page 62 and “Appendix A, Command Function Reference” on page 80 to create the desired application pattern for the workpiece or group of workpieces.

PREREQUISITES

- ❑ The system is properly set up. Refer to “Setting Up and Calibrating the System (Required)” on page 40.
- ❑ If the tip or any element of the Z axis head was changed, repeat system setup and calibration using the Robot Initial Setup wizard. Refer to “Setting Up the System Using the Robot Initial Setup Wizard” on page 43.
- ❑ The system is in the correct mode (Tip or CCD).
- ❑ A workpiece is properly positioned on the fixture plate.



#	Click	Step
1		<ul style="list-style-type: none"> • Click the PROGRAM tab. <p>Address 1 is available to insert a command.</p>
2		<ul style="list-style-type: none"> • Jog the dispensing tip to a desired XYZR location by clicking the navigation icons.
3		<ul style="list-style-type: none"> • Insert a setup or dispense command that tells the robot what to do. Click a command icon, or double-click anywhere in the address line to select a command from the drop-down menu.
4		<ul style="list-style-type: none"> • Edit the command parameter settings. Refer to the following sections of this manual for information to help you create programs: <ul style="list-style-type: none"> - “About Programs and Commands” on page 22 (includes best practices) - “How to Create Patterns” on page 62 - “How to Create a Mark” on page 66 - “Appendix A, Command Function Reference” on page 80 (provides detailed information on all commands)
5		<ul style="list-style-type: none"> • Repeat steps 2 through 4 until the program is complete.
6		<ul style="list-style-type: none"> • To delete a command, click the command and then click the Delete icon.
7		<ul style="list-style-type: none"> • Click END PROGRAM to end the program.
8		<ul style="list-style-type: none"> • Click VIEW or RUN to test the program and make adjustments until the program runs correctly. <p>NOTE: VIEW runs a program without dispensing fluid. RUN runs the actual program, including dispensing.</p>
9		<ul style="list-style-type: none"> • Click A NEW FILE. • Click SAVE. If the file is not already named, enter a name for the file. • Click YES/OK when prompted for confirmations.

How to Add Comments to a Program

You can add your own comments to any command address line in a program.

PREREQUISITES

- ❑ The program you want to add comments to is open.

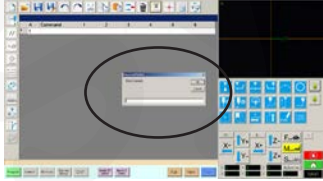
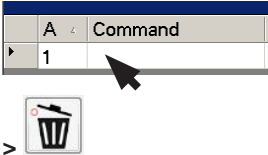
#	Click	Step	Reference Image
1		<ul style="list-style-type: none"> Select a blank command address line. <p>NOTE: Comments must be entered on a blank line. If you try to enter a comment on a line that includes a command, you will disable the command.</p>	
2		<ul style="list-style-type: none"> Click DISABLE ADDRESS. Enter your comment in the Enter Comment window. Close the window. 	
3		<ul style="list-style-type: none"> To delete a comment, select the comment and then click DELETE. 	



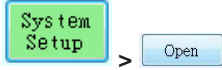
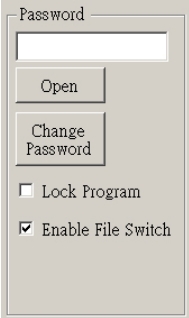

How to Lock or Unlock a Program

Use the Lock Program checkbox on the System Setup screen to protect a program from unauthorized editing. When Lock Program is checked, operators can only RUN, VIEW, or PAUSE the currently open program.

#	Click	Step
1		<ul style="list-style-type: none"> Open the program you want to lock. It should be visible when the Program tab is selected.
2		<ul style="list-style-type: none"> Click SYSTEM SETUP > OPEN. If requested, enter the password.
3		<ul style="list-style-type: none"> Under Password, check LOCK PROGRAM to lock or unlock a program: <ul style="list-style-type: none"> - If LOCK PROGRAM is checked, the currently open program will be locked from editing and cannot be changed. - If LOCK PROGRAM is NOT checked, the currently open program will be unlocked and can be changed. - If ENABLE FILE SWITCH is checked, the operator can switch programs when LOCK PROGRAM is checked.

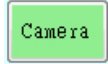
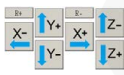
How to Measure a Path or Circle on a Workpiece

The system can measure the distance between two points or the diameter of a circle on a workpiece.

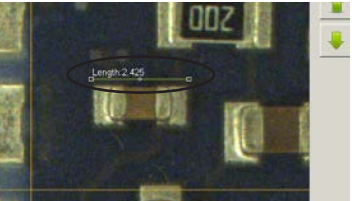
#	Click	Step	Reference Image
1		<ul style="list-style-type: none"> Click CAMERA to go to the camera screen. 	
2		<ul style="list-style-type: none"> Jog the camera until the area on the workpiece to be measured is in the camera view and then focus the camera if needed. 	
3	 	<ul style="list-style-type: none"> To measure a line, click the MEASURE LENGTH icon. To measure the diameter of a circle, click the MEASURE CIRCLE DIAMETER icon. 	
4		<ul style="list-style-type: none"> To remove the measuring tool, right click the center of Measure Length or Measure Circle and then click DELETE. 	

How to Create Patterns

The vision-guided automated dispensing software give you the ability to create patterns many ways. This part of the manual provides example programming for some of the most common command sequences. Use these examples as a guideline for making other patterns. Refer to “Appendix A, Command Function Reference” on page 80 for detailed information on all commands. Refer to “How to Use the Example Icon” on page 63 for some pre-programmed example programs already created in the DispenseMotion software.

Dispense Dot Sample Program

A	Command	1	2	3	4	5	6
1	Z Clearance Setup	10	1				
2	Dispense Dot Setu	0.5	0.1				
3	Dispense End Setu	100	5	5			
4	Dispense Dot	0	0	0	0		
5	Dispense Dot	50	50	0	90		
6	Dispense Dot	20	0	0	180		
7	End Program						



Lines and Arcs Sample Program

A	Command	1	2	3	4	5	6
1	Z Clearance Setup	5	1				
2	Line dispense Setu	0	0	0	0	0	0
3	Line Speed	1					
4	Line Start	0	0	0	0		
5	Line Passing	50	0	0	0		
6	Arc Point	75	25	0	0		
7	Line Passing	50	50	0	0		
8	Line End	0	50	0	0		
9	End Program						

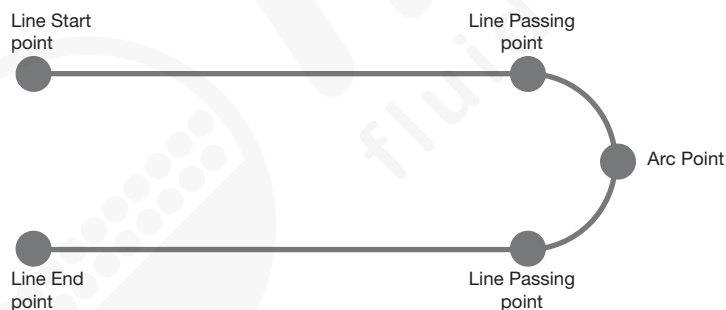

How to Create Patterns (continued)

Circle Sample Program

NOTES:

- The X and Y parameters are the center of the circle.
- The diameter of the circle on the workpiece was measured as 5.5 mm. Click the Measure Circle Diameter icon on the Camera screen to measure the diameter of a circle on a workpiece. Refer to “How to Measure a Path or Circle on a Workpiece” on page 61.
- Do not use a non-zero rotation angle in a circle command; doing so will cause the rotation angle to reset to 0 when the command occurs.

A	Command	1	2	3	4	5	6
1	Z Clearance Setup	0	0				
2	Label	1					
3	Fiducial Mark	0	100	40	19		
4	Fiducial Mark	200	100	40	19		
5	Step & Repeat X	5	5	5	5	1	10001
6	Label	2					
7	Fiducial Mark Adjus						
8	Dispense Dot	113.389	38.39	50.938			
9	Circle	113.389	38.39	50.938	40	0	360
10	Step & Repeat X	5	5	5	5	1	10002
11	End Program						

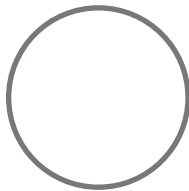

How to Use the Example Icon

A selection of pre-programmed sets of commands are available when you click the Example icon. You can use these programs as a starting point for any program.

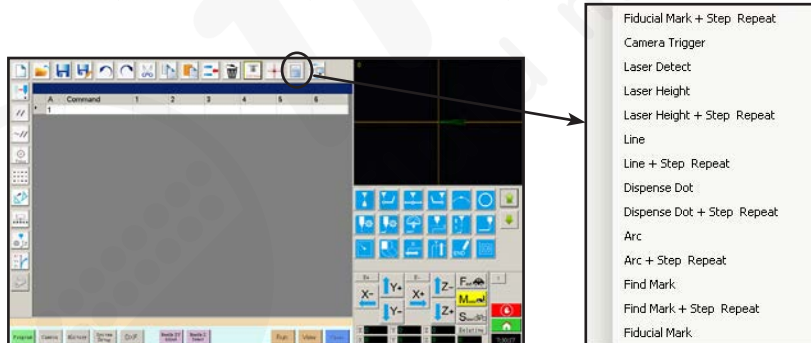



How to Dispense on Multiple Workpieces in an Array

Use the Step & Repeat commands to dispense the same pattern on multiple workpieces in an array.

NOTE: You can use the Step & Repeat Block icon to disable dispensing for workpieces not present. Refer to “How to Disable Dispensing for Specific Workpieces in an Array” on page 65.

PREREQUISITES

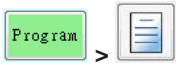
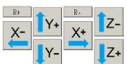
- ❑ The system is properly set up. Refer to “Setting Up and Calibrating the System (Required)” on page 40.
- ❑ If the tip or any element of the Z axis head was changed, repeat system setup and calibration using the Robot Initial Setup wizard. Refer to “Setting Up the System Using the Robot Initial Setup Wizard” on page 43.
- ❑ The system is in the CCD Mode.
- ❑ Multiple workpieces are properly positioned on the fixture plate.

#	Click	Step
1		<ul style="list-style-type: none"> Click the PROGRAM tab, then click the Example icon and select FIND MARK + STEP REPEAT. Click YES when prompted for confirmation. <p>A sample Step & Repeat X program appears.</p> <p>NOTE: You can also use Step & Repeat Y to dispense onto multiple pieces in an array. Refer to “Appendix A, Command Function Reference” on page 80 for detailed information on both Step & Repeat commands.</p>
2		<ul style="list-style-type: none"> Jog the dispensing tip to the first workpiece in the array and create a mark. Refer to “How to Create a Mark” on page 66 as needed.
3		<ul style="list-style-type: none"> Double-click the FIND MARK command and enter the number of the mark created in step 2.
4		<ul style="list-style-type: none"> Double-click the remaining commands and enter the parameters that will work for your array. Refer to “Appendix A, Command Function Reference” on page 80 for detailed information on commands.
5		<ul style="list-style-type: none"> Click END PROGRAM to end the program.
6		<ul style="list-style-type: none"> Test the program and make adjustments until the program runs correctly.

A	Command	1	2	3	4	5	6
1	Z Clearance Setup	20	1				
2	Label	1					
3	Fiducial Mark	0	0	0	1		
4	Fiducial Mark	0	0	0	2		
5	Line dispense Setu	0.5	2	0.6	1.5	3	0.7
6	Dispense End Setu	100	5	5			
7	Line Speed	10					
8	Line Start	0	0	0			
9	Line Passing	10	0	0			
10	Line End	0	10	0			
11	Step & Repeat X	10	10	2	2	1	10001
12	End Program						



How to Disable Dispensing for Specific Workpieces in an Array

You can use the Step & Repeat Block icon to disable or enable dispensing for specific workpieces in an array.





NOTE: Use the Step & Repeat commands to create a program that dispenses the same pattern on multiple workpieces in an array. Refer to “How to Dispense on Multiple Workpieces in an Array” on page 64.

PREREQUISITES

- ❑ The system is properly set up. Refer to “Setting Up and Calibrating the System (Required)” on page 40.
- ❑ The system is in the CCD Mode.
- ❑ Multiple workpieces are properly positioned on the fixture plate.
- ❑ The correct Step & Repeat program for the array on the fixture plate is open.

#	Click	Step
1		<ul style="list-style-type: none"> • Make sure the Program screen is open.
2		<ul style="list-style-type: none"> • Click the STEP & REPEAT BLOCK icon. <p>The Run Block Select window appears.</p>
3		<ul style="list-style-type: none"> • To disable dispensing for specific workpieces, click the workpiece locations in the window. Selections turn black when disabled. <ul style="list-style-type: none"> - Gray: Enabled - Black: Disabled • Leave the Run Block Select window open during dispensing. <p>NOTE: Refer to “Function of the Icons in the Run Block Select Window” below for the function of the Run Block Select window icons.</p>
4		<ul style="list-style-type: none"> • When dispensing is complete, close the Run Block Select window. The system clears all disabled selections.

Function of the Icons in the Run Block Select Window







Icon Name	Icon	Function
Refresh		Refreshes the window.
Select Entity		Selects a group of blocks.
Cancel Select		Cancels any selections
Toggle Select		Toggles a selected block between enabled and disabled.
Run Block Select		Runs the currently selected and enabled blocks.

How to Create a Mark

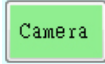
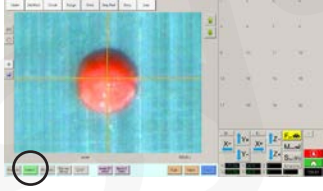
Refer to “About Marks” on page 24 for an explanation of marks. If you want to use fiducial marks in a program to check workpiece orientation, create at least two marks.

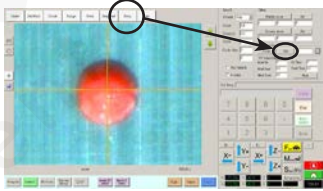
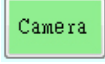
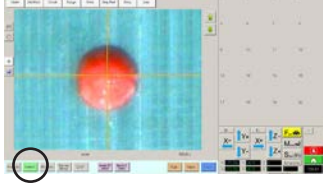
PREREQUISITES

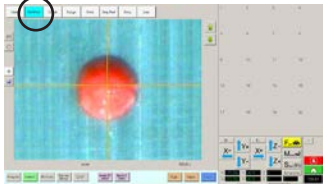
- ❑ The system is properly set up. Refer to “Setting Up and Calibrating the System (Required)” on page 40.
- ❑ If the tip or any element of the Z axis head was changed, repeat system setup and calibration using the Robot Initial Setup wizard. Refer to “Setting Up the System Using the Robot Initial Setup Wizard” on page 43.
- ❑ The system is in the CCD Mode.

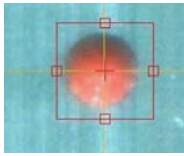
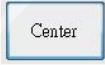
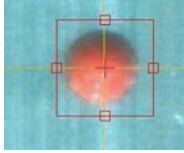
#	Click	Step	Reference Image
1		<ul style="list-style-type: none"> • Click CAMERA to go to the camera screen. 	
2		<ul style="list-style-type: none"> • Bring the image into focus. Refer to “Camera” on page 16 as needed for instructions on focusing the camera. 	
3		<ul style="list-style-type: none"> • Click SETUP to go back to the Camera window Offset fields. • Click SET next to Focus in the Offset portion of the Camera Setup screen. 	
4		<ul style="list-style-type: none"> • Click the CAMERA tab. 	
5		<ul style="list-style-type: none"> • Click SET MARK. A red box appears. 	
6		<ul style="list-style-type: none"> • Click and hold the center of the red box, drag it over the dispense dot, and then click and drag the four box handles such that they outline the dot. 	
7		<ul style="list-style-type: none"> • Click CENTER to center the red cross mark on the target. 	

Continued on next page

How to Create a Mark (continued)

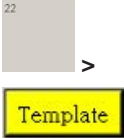
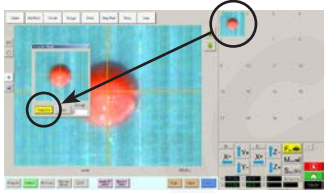
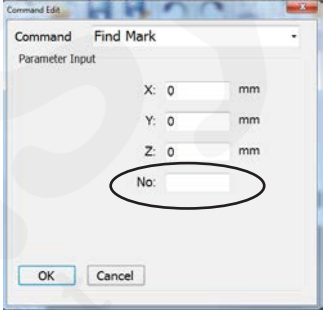

#	Click	Step	Reference Image
8		<ul style="list-style-type: none"> Click a socket in the Mark Library to save the mark, then click TEMPLATE when the Template Match window appears. <p>The system saves the image in the Mark Library.</p> <p>NOTE: If there are many areas on the workpiece that resemble the mark you saved, you can fine-tune how the camera finds and evaluates the mark. Click AREA and refer to “How to Improve the Accuracy of Mark Searches” below for detailed information.</p>	
		<p>You can specify any mark in the Mark Library within a Find Mark or Fiducial Mark command by entering the mark number (No.) in the Parameter Input window. Refer to “How to Use Marks or Fiducial Marks in a Program” on page 68.</p>	

How to Improve the Accuracy of Mark Searches

If there are many areas on a workpiece that resemble a mark you saved, you can use the Area function of the Template Match window to fine-tune how the camera evaluates these areas against the saved mark image. Doing so increases the find-mark accuracy of the system.

PREREQUISITES

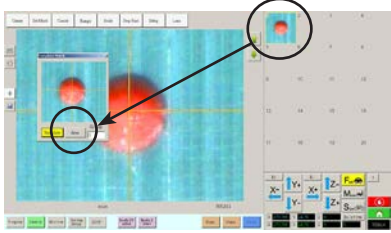
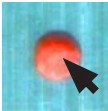
- The system is in the CCD Mode.
- The mark you want to fine-tune is saved in the Mark Library.

#	Click	Step	Reference Image
1		<ul style="list-style-type: none"> Click CAMERA to go to the camera screen. 	
2		<ul style="list-style-type: none"> Double-click any image in the Mark Library. <p>The Template Match window appears.</p>	
3		<ul style="list-style-type: none"> Click AREA. Refer to “Template Match and Area Windows” on page 34 to use the Area window to fine-tune how the camera searches for and evaluates the image against other similar areas on the workpiece. 	

How to Use Marks or Fiducial Marks in a Program

Use the Mark command in a program as follows:

- To confirm the presence or absence of a workpiece.
- To confirm that the correct workpiece is present.
- To check the XY position of a workpiece.

Use two Fiducial Marks in a program as follows:

- To move the dispensing tip to a specific target area on the workpiece.
- To check the XY orientation of a workpiece. The system automatically adjusts the program to compensate for any changes in orientation.

PREREQUISITES

- The system is properly set up. Refer to “Setting Up and Calibrating the System (Required)” on page 40.
- The system is in the CCD Mode.

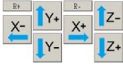
#	Click	Step
1		<ul style="list-style-type: none"> • Determine whether you need to create one mark or two and then create the marks. Refer to “How to Create a Mark” on page 66 for the procedure for creating marks.
2		<ul style="list-style-type: none"> • Enter a Find Mark command or two Find Fiducial Mark commands near the beginning of a program.
3		<ul style="list-style-type: none"> • If the program includes a Step & Repeat command, use the Mark Adjust or Fiducial Mark Adjust commands.
4		<ul style="list-style-type: none"> • Refer to the sample program below as a guideline.

A	Command	1	2	3	4	5	6
1	Z Clearance Setup	0	0				
2	Label	1					
3	Find Mark	158.896	30.442	46.555	19		
4	Step & Repeat X	5	5	5	5	1	10001
5	Label	2					
6	Mark Adjust						
7	Dispense Dot	113.389	38.39	50.938			
8	Dispense Dot	113.224	38.394	50.938			
9	Step & Repeat X	5	5	5	5	1	10002
10	End Program						

A	Command	1	2	3	4	5	6
1	Z Clearance Setup	20	1				
2	Label	1					
3	Fiducial Mark	0	0	0	1		
4	Fiducial Mark	0	0	0	2		
5	Line dispense Setu	0.5	2	0.6	1.5	3	0.7
6	Dispense End Setu	100	5	5			
7	Line Speed	10					
8	Line Start	0	0	0			
9	Line Passing	10	0	0			
10	Line End	0	10	0			
11	Step & Repeat X	10	10	2	2	1	10001
12	End Program						
13							

How to Set Up Auto Purge, Program Cycle Limits, or Fluid Working Life Limits





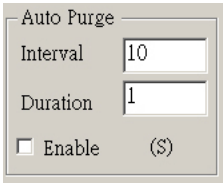
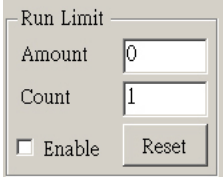
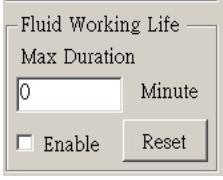

The System Setup screen includes the following automatic functions that can be applied to any program. These functions operate correctly only when the following conditions are met:

- The Enable checkbox for the function is checked.
- The program is locked (refer to “How to Lock or Unlock a Program” on page 61).

Function	Screen Capture	Description
Auto Purge		<p>If Auto Purge is enabled, the system performs an automatic purge at the Park Position using the values entered for Interval and Duration:</p> <ul style="list-style-type: none"> • Interval: How long the system must be idle (robot START button not pressed) before Auto Purge begins. • Duration: How long the system purges in intervals of 1 second. <p>EXAMPLE: If Auto Purge is enabled with the values shown at left, the system automatically dispenses fluid for 1 second every 10 seconds at the specified Park Position.</p>
Run Limit		<p>If Run Limit is enabled for a program, the number of times the system runs a program (called a program cycle) is limited according to the values entered for Amount and Count:</p> <ul style="list-style-type: none"> • Amount: Sets the number of times a program can run. • Count: Shows how many times a program has run. <p>To reset Amount and Count to 0, click RESET.</p>
Fluid Working Life		<p>If Fluid Working Life is enabled, sets the maximum number of minutes that a fluid should be in the system (also known as pot life). When the value entered for Max Duration is reached, the system provides an indication but does not disable operation.</p> <p>To reset Max Duration to 0, click RESET.</p>

PREREQUISITES

- ❑ The system is properly set up. Refer to “Setting Up and Calibrating the System (Required)” on page 40.
- ❑ The program to which you want to apply Auto Purge, Run Limit, or Fluid Working Life settings is complete and operating properly.





#	Click	Step
1	 > 	<ul style="list-style-type: none"> • Click PROGRAM > OPEN to open the program to be updated.
2	 > 	<ul style="list-style-type: none"> • Click SYSTEM SETUP, then click OPEN.
3		<ul style="list-style-type: none"> • Refer to the table above to enter settings for Auto Purge, Run Limit, or Fluid Working Life.
4		<ul style="list-style-type: none"> • Click the ENABLE checkbox for the function you want to enable for the open program.
5		<ul style="list-style-type: none"> • Lock the program (refer to “How to Lock or Unlock a Program” on page 61).
6		<ul style="list-style-type: none"> • To restart a program cycle after Run Limit or Fluid Working Life values are exceeded, repeat steps 1–2, enter the password, and click RESET.

How to Use Point Offset to Adjust All Points in a Program

You can click the Point Offset icon to update all points in a program when the position of a workpiece has changed.

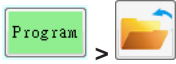
PREREQUISITES

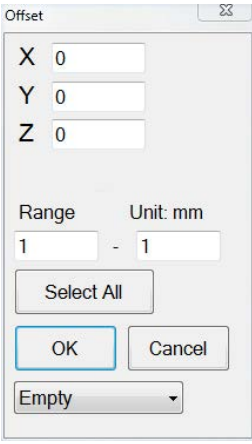
- ❑ The system is properly set up. Refer to “Setting Up and Calibrating the System (Required)” on page 40.
- ❑ The program to be updated was correct and working properly before the workpiece position was changed.

#	Click	Step
1		<ul style="list-style-type: none"> • Click PROGRAM > OPEN to open the program to be updated.
2		<ul style="list-style-type: none"> • Click the POINT OFFSET icon. <p>The Offset window appears.</p>
3		<ul style="list-style-type: none"> • Compare the previous XYZR position of one point in the program to its new XYZR position and determine the amount of offset for each XYZR value.
4		<ul style="list-style-type: none"> • Enter the offset values in the X, Y, and Z fields of the Offset window and update the other fields in this window as follows: <ul style="list-style-type: none"> - To limit the XYZR offset changes to a specific range of addresses in the program, enter the address number range under RANGE. - To select all the addresses in the program, click SELECT ALL. - To select only a specific type of command, use the drop-down menu. Otherwise, leave this selection as EMPTY. <p>EXAMPLE: The XYZR coordinates of a point were 1, 2, and 3. The new XYZR coordinates of that same point are now 6, 7, and 8. The amount of offset for each point equals 5, so you enter “5” in the X, Y, and Z fields in the Offset window.</p> <p>NOTE: “Unit: mm” indicates the unit of measure used in commands. This item is not editable.</p>
5		<ul style="list-style-type: none"> • Click OK.

Operation

After the system is installed and programmed, the only actions required from the operator are to switch on the system, run the program for the workpiece, and shut down the system at the end of the work period.

Starting the System and Running a Program

1. Switch on the DispenseMotion controller, monitor, and robot.
2. Double-click the DispenseMotion icon to open the dispensing software.
3. Click HOME.
The robot moves the camera to the home position (0,0,0) and the system is ready.

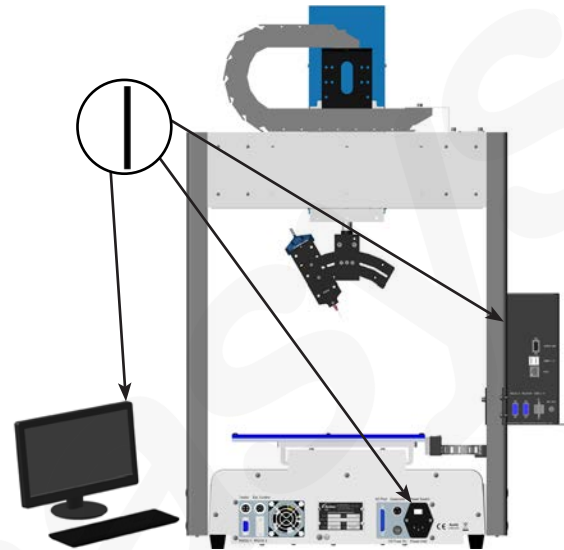

4. Enable the dispensing system, including the valve controller. Refer to the dispensing equipment manuals as needed.
5. Open the program file for your application.
6. Place the workpiece in the correct location on the fixture plate.
7. Press the START button on the front of the robot, or click RUN on the monitor.
8. When necessary, refer to the dispensing system manuals to refill the dispenser.
9. If an emergency occurs, press the EMERGENCY STOP button.

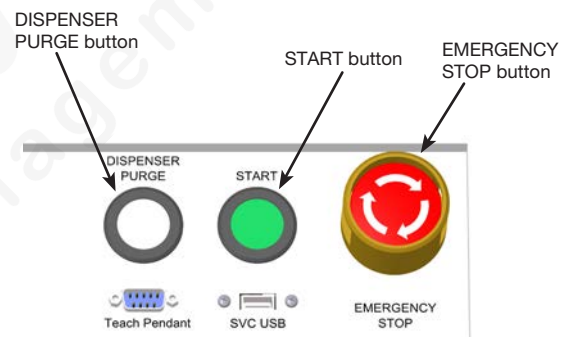

Running a Program by Scanning a QR Code

PREREQUISITES

- ❑ QR code scanning is enabled. Refer to “Appendix D, QR Code Scanning Setup” on page 105 to enable QR code scanning.
- ❑ A QR code is present on the robot work surface and is associated with a program. Refer to “Appendix D, QR Code Scanning Setup” on page 105 to associate a QR code with a program.

1. Position the workpiece on the fixture plate.
2. Press the START button on the front of the robot, or click RUN on the monitor.

The system jogs to the predefined location where a QR code is located, scans the QR code, opens the associated program, and executes the program.

Pausing During a Dispense Cycle

Press START at any time to pause the system during a dispense cycle; the pauses at its current position.

NOTE: If the system is paused when the dispenser is open, pattern integrity will be compromised.

Purging the System

To purge the system, press the DISPENSER PURGE button.

NOTE: You can set up the system to purge automatically. Refer to “How to Set Up Auto Purge, Program Cycle Limits, or Fluid Working Life Limits” on page 69.

Updating Offsets

Needle Z Detect

After running a program repeatedly for several hours, click NEEDLE Z DETECT (systems with tip detection) or NEEDLE XY ADJUST (systems without a tip detection) to update the system to compensate for minute changes that can occur after long periods of operation.

Refer to “How the System Responds to Needle Z Detect or Needle XY Adjust” on page 52 for a detailed description of the system response to a Needle XY Adjust selection.

Shutting Down the System

1. Click SYSTEM SETUP > EXIT to close the DispenseMotion software. If prompted to save a file, select YES or NO.
2. Switch off the following components:
 - DispenseMotion controller
 - Monitor
 - Robot
3. Refer to the dispensing system manuals for any special shutdown instructions.

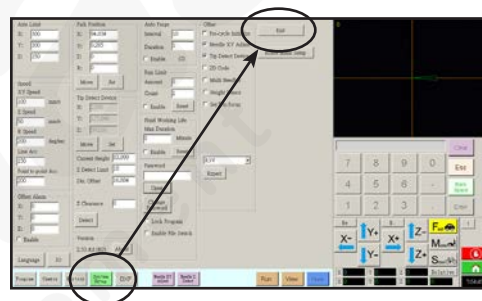

Part Numbers

Part # / Model	R3V	R4V	R6V
Part # (robot with fixed-mount camera*)	7363556	7363557	7363558
Part # (robot with rotating-mount camera)	7363673 (base robot, no vision) 7364066 (vision kit)	7363675 (base robot, no vision) 7364066 (vision kit)	7363677 (base robot, no vision) 7364066 (vision kit)
Order all part #s listed. Vision kit includes camera, PC, monitor, keyboard, and mouse.			
Part # Europe* (robot with fixed-mount camera)	7361913	7361915	7361917
Part # Europe* (robot with rotating-mount camera)	7363674 (base robot, no vision) 7364067 (vision kit) 7727235 (keyboard and mouse)	7363676 (base robot, no vision) 7364067 (vision kit) 7727235 (keyboard and mouse)	7363678 (base robot, no vision) 7364067 (vision kit) 7727235 (keyboard and mouse)
Order all part #s listed. Vision kit includes camera, PC, and monitor.			

*Complies with European safety regulations.

Accessories

NOTE: For replacement parts, refer to the maintenance and parts guide, available at www.nordsonefd.com/RobotMaintenanceGuide.

Safety Enclosures



Nordson EFD guarded safety enclosures integrate seamlessly with our complete line of automated dispensing systems. Featuring external dispensing controls, a safety light curtain, and an internal electrical control box and wireways for faster, safer setup, these CE-compliant enclosures also fully comply with EU Machinery Directive 2006/42/EC.

Part #	Description	Compatible Robot Models
7362738	Small safety enclosure	R3V
7362766	Small safety enclosure, Europe	
7362739	Large safety enclosure	R4V
7362767	Large safety enclosure, Europe	

Pre-Configured Output Cables

Item	Part #	Description
	7360551	Standard cable to connect the dispenser and the robot
	7360761	Single voltage initiate cable to connect the dispenser and the robot (provides different pigtails to connect to different dispensers / controllers)
	7360554	Dual voltage initiate cable to connect up to two dispensers / controllers to the robot
	7362573	I/O interface cable between the ValveMate™ 8000 and the robot when the use of all four (4) ValveMate 8000 channels are required
	7360558	Dual-connector cable to connect up to two PICO® DCON Drivers or two PICO Touch™ controllers to the robot
	7362356	Dual-connector cable to connect up to two Liquidyn® V10 controllers to the robot
	7362357	Dual-connector cable to connect up to two Liquidyn V200 controllers to the robot
	7362373	Single-connector cable to connect a Liquidyn V200 controller to the robot

Accessories (continued)

Fixture Plates

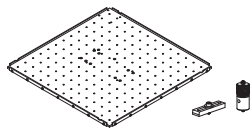

All plates include four edge levelers and four leveling mounts.

Part #	Description
7362547	300 mm fixture plate
7362548	400 mm fixture plate
7362549	600 mm fixture plate

Start / Stop Box

The start / stop box accessory facilitates input / output connections for remote functions, such as an start or emergency stop button. Refer to “Example Input / Output Connections” on page 79 for schematics.

Part #	Description
7363285	Start / stop accessory box and I/O checker, standard The I/O checker allows a user / programmer to simulate either (1) input signals from external devices or (2) outputs from the automation before physically installing any external devices.
7360865	Start / stop accessory box, European Community







Tip Detection Kits

The optional tip detector or tip alignment devices allow you to automatically update both the XY offsets and the Z height by clicking on Needle Z Detect. The Needle Z Detect button is present only on systems that include a tip detection device. Refer to “Setting Up the Optional Tip Detector or Tip Alignment Device” on page 98 to set up the tip detector.

Item	Part #	Description
	7360893	Tip detector accessory kit, EV, RV Series
	7362353	Tip alignment accessory kit, R, RV Series The tip alignment device performs the same function as the standard tip detector, but without requiring the tip to touch a sensor. This device should be installed if the workpiece is 15 mm (0.6"), or more, higher than the tip detector.
	7363940	Top mount / under mount accessory kit This kit allows you to mount the tip detector in the center of the robot fixture plate, either on top of the plate or under the plate, to facilitate multi-needle or other applications.

Accessories (continued)

Mounting Brackets

Item	Part #	Description	Item	Part #	Description
	7360610	Syringe barrel mounting bracket		7363518	Mounting bracket for 794-TC Series valves
	7361815	Mounting bracket for PICO <i>Pulse</i> ™ valves		7361114	Mounting bracket for xQR41 and 745 Series valves
	7360613	Mounting bracket for all valves with mounting holes (752, 725, 741, 736, 781, 787, and 782 Series valves)		7362177	Mounting bracket for Liquidyn P-Jet and P-Dot valves
	7361758	Universal valve mounting bracket for all valves without mounting holes (702, 754, 794, and 784S-SS Series valves)			

Technical Data

Dimensions

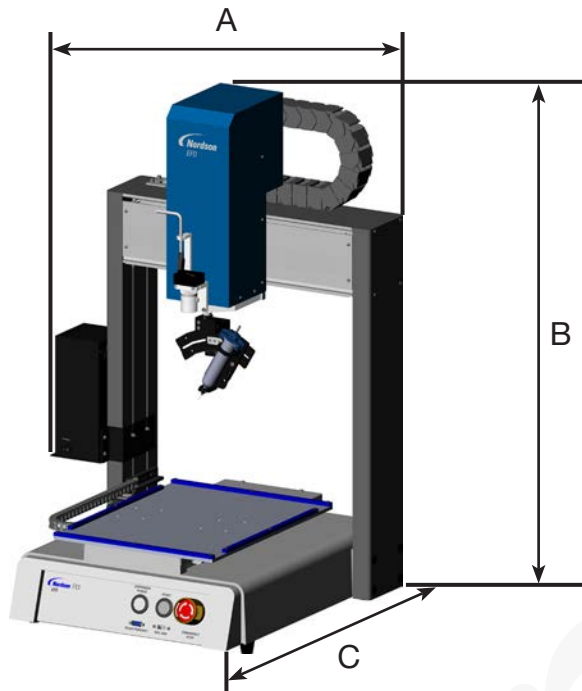

Dimension	R3V	R4V	R6V
A (width)	645 mm (25")	745 mm (29")	965 mm (38")
B (height)	914 mm (36")	914 mm (36")	914 mm (36")
C (depth)	552 mm (22")	652 mm (26")	752 mm (30")

Robot Feet Mounting Hole Template

Use these dimensions to drill mounting holes for the robot feet.

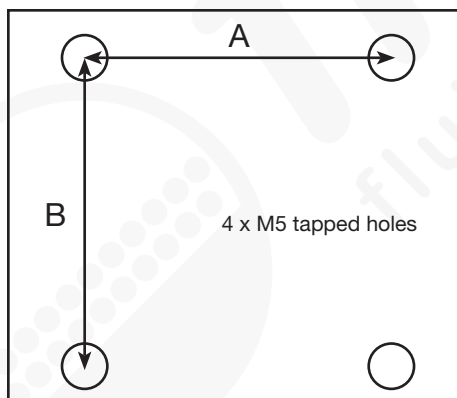

Dimension	R3V	R4V	R6V
A	400 mm (15.75")	500 mm (19.69")	500 mm (19.69")
B	410 mm (16.14")	510 mm (20.08")	510 mm (20.08")

Technical Data (continued)

Wiring Diagrams

Dispenser Port

Pin#	Description
1	NOM (Normally open)
2	COM (Common)
3	EARTH (Ground)

Maximum Voltage	Maximum Current
125 VAC	15A
250 VAC	10A
28 VDC	8A

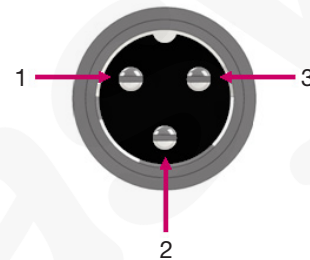
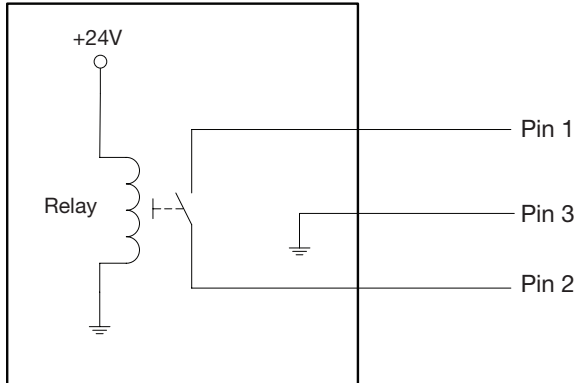

Ext. Control Port

NOTES:

- Inputs are not polarity-sensitive.
- The optional start / stop box accessory facilitates input / output connections to this port. Refer to “Start / Stop Box” on page 74 for part numbers.

Pin	Description
1	Ground
2	Start signal
3	Motor power
4	Motion idle
5	Run / Teach
6	Emergency stop
7	Emergency stop

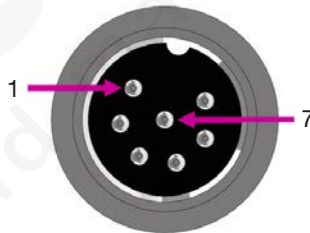

Technical Data (continued)

I/O Port

NOTES:

- Outputs are rated at 125 mA.
- Courtesy +24 VDC output is rated at 3.0 Amp.

Pin	Description	Pin	Description	Pin	Description
1	Input 1	10	Not connected	19	Output 6
2	Input 2	11	GND	20	Output 7
3	Input 3	12	GND	21	Output 8
4	Input 4	13	GND	22	Not connected
5	Input 5	14	Output 1	23	Not connected
6	Input 6	15	Output 2	24	+24 VDC
7	Input 7	16	Output 3	25	+24 VDC
8	Input 8	17	Output 4		
9	Not connected	18	Output 5		

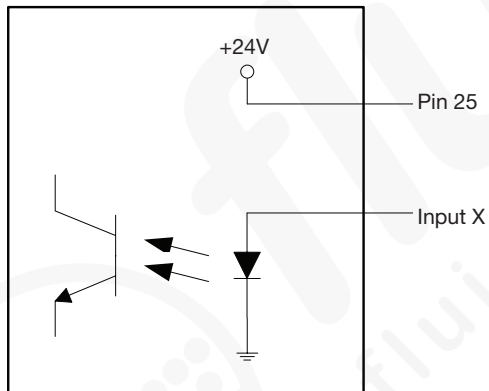
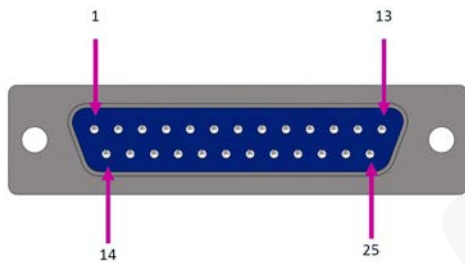

Input schematic

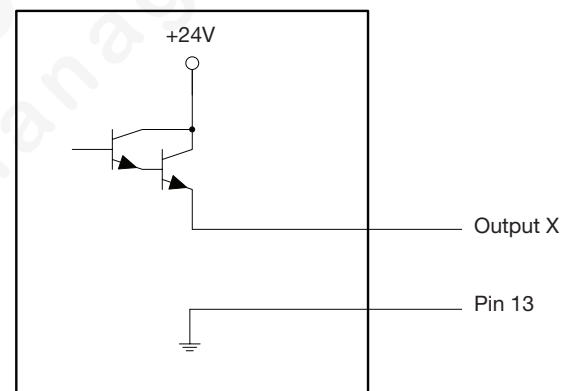

Output schematic

Technical Data (continued)

Example Input / Output Connections

You can use the I/O Port and Ext. Control port on the back of the robot to connect a variety of inputs and outputs. A spare connector is also provided with the system. The following schematics show typical examples of input / output connections to a robot.

Inputs

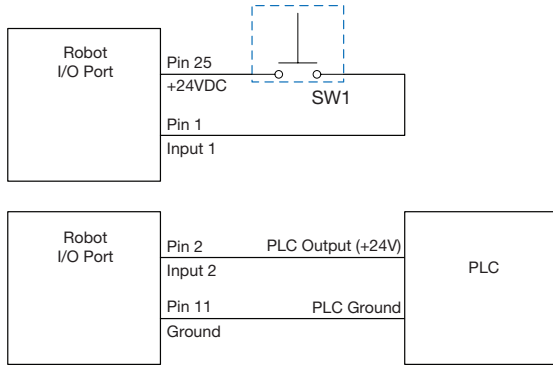

Outputs

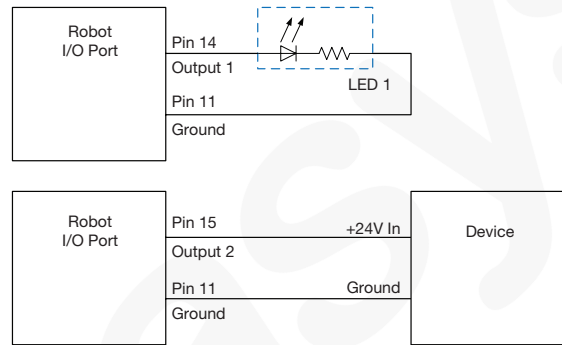

Outputs are rated at 125 mA.

External Device Powered by the Robot

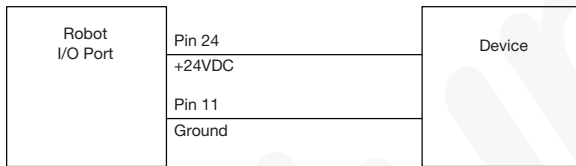

Courtesy +24 VDC output is rated at 3.0 Amp.

Start and Emergency Stop (ESTOP) Connections to Ext. Control

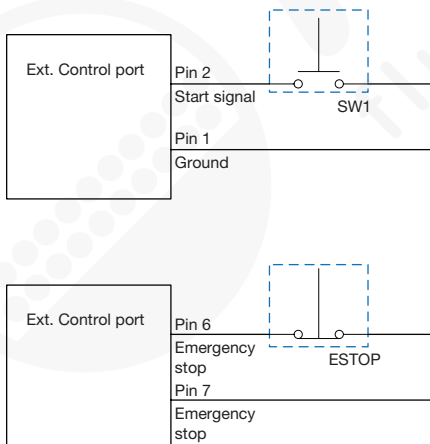



Appendix A, Command Function Reference

This appendix provides detailed information for each setup and dispense command. Commands are in alphabetical order.

The following rules apply to all commands:

- A command is in effect until it is superseded by another command.
- Command settings override system settings.

Acceleration		
Click	Function	
	Controls the acceleration of the robot from point to point (ptp) or along a continuous path (cp). In general, the value of this parameter is inversely related to the robot's acceleration.	
	Parameter	Description
	0:ptp 1:cp	Toggles the acceleration control between point to point (ptp) or continuous path (cp).
	Value	Sets the rate of acceleration from point to point or on a continuous path. Range: 20–500

Arc Point	
Click	Function
	Registers the current XYZR location as an Arc Point. Arc Points dispense fluid along an arched path.

Backtrack Setup		
Click	Function	
	Sets how the dispensing tip raises at the end of line dispensing. This is useful for high-viscosity or stringy fluids to control where the fluid tail falls. The illustrations on the next page provide visual a representation of the Backtrack Setup selections.	
	Parameter	Description
	Backtrack Length	Distance the dispensing tip travels away from the Line End point.
	Backtrack Gap	Distance the dispensing tip raises as it moves away from the Line End point. This value must be less than the Z Clearance value for that point.
	Backtrack Speed	Speed at which the dispensing tip moves either (1) back and up along the retract path to reverse direction after line dispensing or (2) forward and up at an angle after line dispensing.
	Type	<p>0 or blank (Normal) The dispensing tip moves straight up for the height entered for Backtrack Gap.</p> <p>1 (Back) The dispensing tip moves backward at an angle for the distance and height entered for Backtrack Length and Backtrack Gap.</p> <p>2 (Square Back) The dispensing tip moves up and then back at the distance and height entered for Backtrack Length and Backtrack Gap.</p> <p>3 (Forward) The dispensing tip moves forward at an angle for the distance and height entered for Backtrack Length and Backtrack Gap.</p> <p>4 (Square Forward) The dispensing tip moves up and then forward for the distance and height entered for Backtrack Length and Backtrack Gap.</p>

Appendix A, Command Function Reference (continued)

Backtrack Setup (continued)

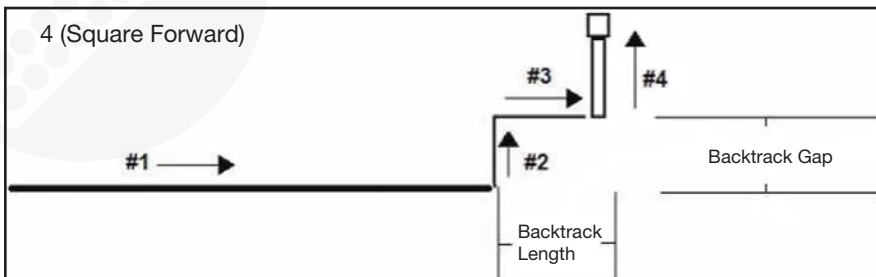
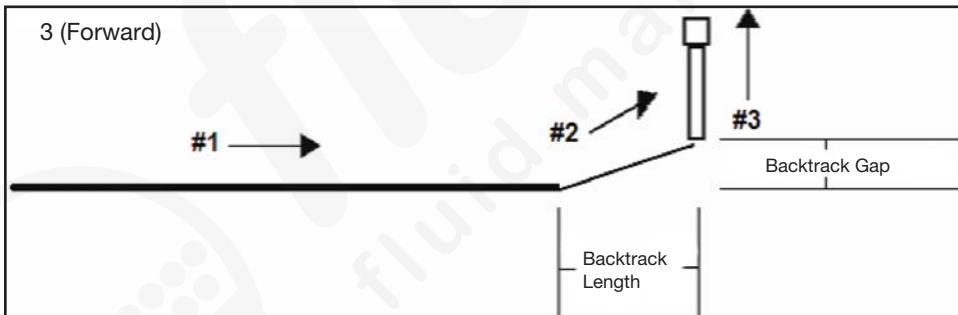
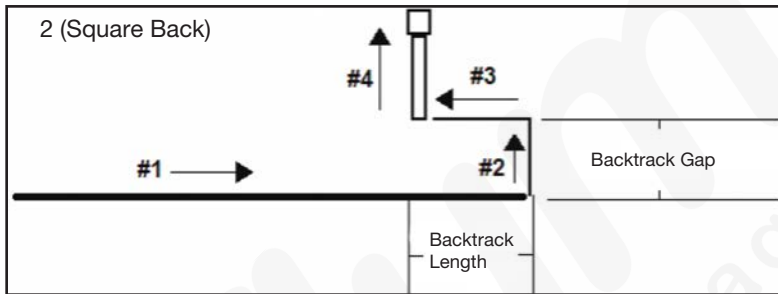
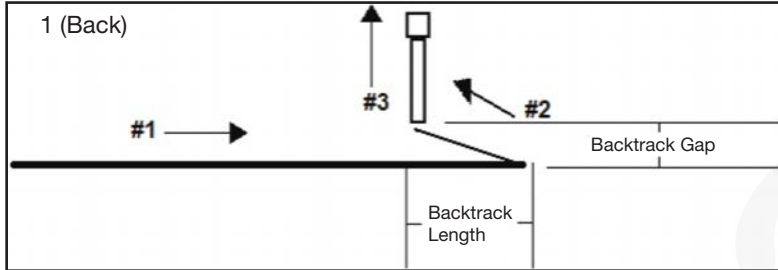

Example illustrations of Backtrack Setup

Appendix A, Command Function Reference (continued)

Call Pattern																																																																																																
Click	Function																																																																																															
Double-click address and select from drop-down menu	Causes the system to dispense in a pattern that is like another pattern in the program, but at the location in the program where the Call Pattern command occurs. The called pattern must have a Label assigned to it. The system stops dispensing the called pattern when it reaches an End Pattern command.																																																																																															
<table border="1"> <thead> <tr> <th>A</th> <th>Command</th> <th>1</th> <th>2</th> <th>3</th> <th>4</th> <th>5</th> </tr> </thead> <tbody> <tr> <td>1</td> <td>Call Pattern</td> <td>62.097</td> <td>85.371</td> <td>47.45</td> <td>1</td> <td></td> </tr> <tr> <td>2</td> <td>Call Pattern</td> <td>62.097</td> <td>85.371</td> <td>27.45</td> <td>1</td> <td></td> </tr> <tr> <td>3</td> <td>End Program</td> <td></td> <td></td> <td></td> <td></td> <td></td> </tr> <tr> <td>4</td> <td></td> <td></td> <td></td> <td></td> <td></td> <td></td> </tr> <tr> <td>5</td> <td>Label</td> <td>1</td> <td></td> <td></td> <td></td> <td></td> </tr> <tr> <td>6</td> <td>Line Start</td> <td>83.055</td> <td>151.983</td> <td>47.45</td> <td></td> <td></td> </tr> <tr> <td>7</td> <td>Line Passing</td> <td>123.129</td> <td>151.874</td> <td>47.45</td> <td></td> <td></td> </tr> <tr> <td>8</td> <td>Line Passing</td> <td>123.05</td> <td>192.069</td> <td>47.45</td> <td></td> <td></td> </tr> <tr> <td>9</td> <td>Line Passing</td> <td>83.091</td> <td>191.932</td> <td>47.45</td> <td></td> <td></td> </tr> <tr> <td>10</td> <td>Line End</td> <td>83.055</td> <td>151.983</td> <td>47.45</td> <td></td> <td></td> </tr> <tr> <td>11</td> <td>End Pattern</td> <td></td> <td></td> <td></td> <td></td> <td></td> </tr> <tr> <td>12</td> <td></td> <td></td> <td></td> <td></td> <td></td> <td></td> </tr> </tbody> </table>						A	Command	1	2	3	4	5	1	Call Pattern	62.097	85.371	47.45	1		2	Call Pattern	62.097	85.371	27.45	1		3	End Program						4							5	Label	1					6	Line Start	83.055	151.983	47.45			7	Line Passing	123.129	151.874	47.45			8	Line Passing	123.05	192.069	47.45			9	Line Passing	83.091	191.932	47.45			10	Line End	83.055	151.983	47.45			11	End Pattern						12						
A	Command	1	2	3	4	5																																																																																										
1	Call Pattern	62.097	85.371	47.45	1																																																																																											
2	Call Pattern	62.097	85.371	27.45	1																																																																																											
3	End Program																																																																																															
4																																																																																																
5	Label	1																																																																																														
6	Line Start	83.055	151.983	47.45																																																																																												
7	Line Passing	123.129	151.874	47.45																																																																																												
8	Line Passing	123.05	192.069	47.45																																																																																												
9	Line Passing	83.091	191.932	47.45																																																																																												
10	Line End	83.055	151.983	47.45																																																																																												
11	End Pattern																																																																																															
12																																																																																																
<i>Example of a program that includes a Call Pattern command</i>																																																																																																

Call Subroutine																																																																																																																																																																						
Click	Function																																																																																																																																																																					
Double-click address and select from drop-down menu	A subroutine is a set of commands that is located after the end of the program. Call Subroutine causes the program to jump to the subroutine at a specified address and then to execute the commands at that address. When the End Subroutine command (which is inside the subroutine) is reached, the program continues at the address that immediately follows the Call Subroutine command. Call Subroutine is most useful for repeating a pattern anywhere on the same workpiece (as opposed to the Step & Repeat command, in which a pattern is repeated on separate workpieces that are arranged in straight lines and at fixed distances from each other).																																																																																																																																																																					
<table border="1"> <thead> <tr> <th>A</th> <th>Command</th> <th>1</th> <th>2</th> <th>3</th> <th>4</th> <th>5</th> <th>6</th> </tr> </thead> <tbody> <tr> <td>1</td> <td>Dispense Dot Setu</td> <td>0.1</td> <td>0</td> <td></td> <td></td> <td></td> <td></td> </tr> <tr> <td>2</td> <td>Line dispense Setu</td> <td>0.2</td> <td>0</td> <td>0</td> <td>0</td> <td>0.1</td> <td>0.1</td> </tr> <tr> <td>3</td> <td>Z Clearance Setup</td> <td>5</td> <td>0</td> <td></td> <td></td> <td></td> <td></td> </tr> <tr> <td>4</td> <td></td> <td></td> <td></td> <td></td> <td></td> <td></td> <td></td> </tr> <tr> <td>5</td> <td>Line Start</td> <td>63.224</td> <td>22.953</td> <td>82.5</td> <td></td> <td></td> <td></td> </tr> <tr> <td>6</td> <td>Arc Point</td> <td>63.282</td> <td>22.812</td> <td>82.5</td> <td></td> <td></td> <td></td> </tr> <tr> <td>7</td> <td>Line Passing</td> <td>63.424</td> <td>22.753</td> <td>82.5</td> <td></td> <td></td> <td></td> </tr> <tr> <td>8</td> <td>Call Subroutine</td> <td>100</td> <td></td> <td></td> <td></td> <td></td> <td></td> </tr> <tr> <td>9</td> <td></td> <td></td> <td></td> <td></td> <td></td> <td></td> <td></td> </tr> <tr> <td>10</td> <td>Line Passing</td> <td>65.274</td> <td>22.753</td> <td>82.5</td> <td></td> <td></td> <td></td> </tr> <tr> <td>11</td> <td>Arc Point</td> <td>65.415</td> <td>22.812</td> <td>82.5</td> <td></td> <td></td> <td></td> </tr> <tr> <td>12</td> <td>Line End</td> <td>65.474</td> <td>22.953</td> <td>82.5</td> <td></td> <td></td> <td></td> </tr> <tr> <td>13</td> <td>End Program</td> <td></td> <td></td> <td></td> <td></td> <td></td> <td></td> </tr> <tr> <td>14</td> <td>Label</td> <td>100</td> <td></td> <td></td> <td></td> <td></td> <td></td> </tr> <tr> <td>15</td> <td>Dispense Dot</td> <td>64</td> <td>23</td> <td>82.5</td> <td></td> <td></td> <td></td> </tr> <tr> <td>16</td> <td>Dispense Dot</td> <td>64.145</td> <td>23</td> <td>82.5</td> <td></td> <td></td> <td></td> </tr> <tr> <td>17</td> <td>Dispense Dot</td> <td>64.25</td> <td>23.5</td> <td>82.5</td> <td></td> <td></td> <td></td> </tr> <tr> <td>18</td> <td>End Subroutine</td> <td></td> <td></td> <td></td> <td></td> <td></td> <td></td> </tr> <tr> <td>19</td> <td></td> <td></td> <td></td> <td></td> <td></td> <td></td> <td></td> </tr> </tbody> </table>							A	Command	1	2	3	4	5	6	1	Dispense Dot Setu	0.1	0					2	Line dispense Setu	0.2	0	0	0	0.1	0.1	3	Z Clearance Setup	5	0					4								5	Line Start	63.224	22.953	82.5				6	Arc Point	63.282	22.812	82.5				7	Line Passing	63.424	22.753	82.5				8	Call Subroutine	100						9								10	Line Passing	65.274	22.753	82.5				11	Arc Point	65.415	22.812	82.5				12	Line End	65.474	22.953	82.5				13	End Program							14	Label	100						15	Dispense Dot	64	23	82.5				16	Dispense Dot	64.145	23	82.5				17	Dispense Dot	64.25	23.5	82.5				18	End Subroutine							19							
A	Command	1	2	3	4	5	6																																																																																																																																																															
1	Dispense Dot Setu	0.1	0																																																																																																																																																																			
2	Line dispense Setu	0.2	0	0	0	0.1	0.1																																																																																																																																																															
3	Z Clearance Setup	5	0																																																																																																																																																																			
4																																																																																																																																																																						
5	Line Start	63.224	22.953	82.5																																																																																																																																																																		
6	Arc Point	63.282	22.812	82.5																																																																																																																																																																		
7	Line Passing	63.424	22.753	82.5																																																																																																																																																																		
8	Call Subroutine	100																																																																																																																																																																				
9																																																																																																																																																																						
10	Line Passing	65.274	22.753	82.5																																																																																																																																																																		
11	Arc Point	65.415	22.812	82.5																																																																																																																																																																		
12	Line End	65.474	22.953	82.5																																																																																																																																																																		
13	End Program																																																																																																																																																																					
14	Label	100																																																																																																																																																																				
15	Dispense Dot	64	23	82.5																																																																																																																																																																		
16	Dispense Dot	64.145	23	82.5																																																																																																																																																																		
17	Dispense Dot	64.25	23.5	82.5																																																																																																																																																																		
18	End Subroutine																																																																																																																																																																					
19																																																																																																																																																																						
<i>Example of a program that includes a Call Subroutine command</i>																																																																																																																																																																						

Appendix A, Command Function Reference (continued)



Circle		
Click	Function	
	Registers a circle with the circle's center at the current XYZ location	
	Parameter	Description
	Diameter	The diameter of the circle (in mm)
	Start Angle	The angle (in degrees) from the center of the circle where the start of the circle begins. The default of 0 degrees equates to the 3:00 position. Default: 0 (degrees) Range: 0 to 360 NOTE: You can enter a negative value. For example, if you enter -90, the circle start point will be the 12:00 position.
End Angle	The angle (in degrees) after the Start Angle value at which dispensing stops. Default: 0 (degrees) To dispense in a counterclockwise direction, enter a negative value.	

Dispense Dot		
Click	Function	
	Registers the current XYZR location as a Dispense Dot point.	

Dispense Dot Setup		
Click	Function	
	Sets how the system dispenses a dot of fluid.	
	Parameter	Description
	Valve On Time	How long the dispenser stays open (in seconds).
	Dwell Time	Delay time (in seconds) that occurs at the end of dispensing to allow the pressure to equalize before the tip moves to the next point.
Head Time	Delay time (in seconds) that occurs at the beginning of dispensing.	

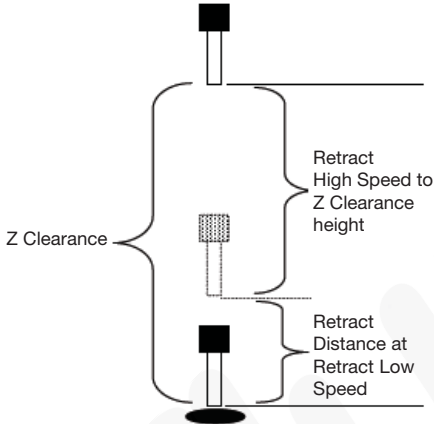
Appendix A, Command Function Reference (continued)

Dispense End Setup		
Click	Function	
	After dispensing a dot or line, it is often required to raise the tip a short distance at a slow speed. This allows the fluid to cleanly break free from the tip to prevent it from being incorrectly applied. The parameters for Dispense End Setup affect how far and how fast the tip raises after dispensing.	
	Parameter	Description
	Retract Low Speed	The speed (in mm/s) at which the tip raises after dispensing. Range: 0–150 mm/s
	Retract High Speed	After the tip raises the amount specified by Retract Distance at the speed specified by Retract Low Speed, the tip continues raising to the Z-clearance height at the speed (in mm/s) specified by this setting. The purpose of specifying a Z-clearance height is to allow the tip to raise high enough to clear any obstacles it encounters on the way to the next point. Range: 0–150 mm/s
Retract Distance	The distance (in mm) the tip raises after dispensing.	
 <p><i>Example illustration of Dispense End Setup</i></p>		

Dispenser Off / Dispenser On	
Click	Function
 	Turns the dispenser OFF or ON at the current address.

Dummy Point		
Click	Function	
	Registers the current XYZR location as a Dummy point. The dispensing tip passes through this point. A dummy point is useful for avoiding obstacles on the workpiece.	
	Parameter	Description
	Speed	The speed (in mm/s) at which the tip moves toward the dummy point. Range: 0–150 mm/s

Appendix A, Command Function Reference (continued)

End Pattern	
Click	Function
Double-click address and select from drop-down menu	Used in tandem with Call Pattern to return the program to the address that occurs just after a Call Pattern command.

End Program	
Click	Function
	Registers the current address as the end of the program. End Program returns the dispensing tip to the home position (0,0,0).

End Subroutine	
Click	Function
Double-click address and select from drop-down menu	Used in tandem with Call Subroutine to return the program to the address that occurs just after a Call Subroutine command.

Fiducial Mark	
Click	Function
	<p>Causes the system to search for the two fiducial marks specified in the No. (number) field of each Fiducial Mark command. The two fiducial marks are then used by the Fiducial Mark Adjust command to adjust the dispensing program accordingly for any orientation changes between workpieces.</p> <p>NOTES:</p> <ul style="list-style-type: none"> • For the best results, enter Fiducial Mark commands before any dispense or setup commands. • Two Fiducial Mark commands must be present in a program for the system to perform this adjustment function correctly. • A Fiducial Mark is different from a Find Mark. A Find Mark is used only to check the XY position of a workpiece whereas a Fiducial Mark is used to check the orientation of a workpiece. • Refer to “About Marks” on page 24 for more information on marks.

Fiducial Mark Adjust	
Click	Function
Double-click address and select from drop-down menu	<p>Adjusts the program (from one workpiece to another) for any XY orientation changes in workpiece placement. The system determines orientation correctness by finding two Fiducial Marks. Refer to “Fiducial Mark” on page 85.</p> <p>NOTES:</p> <ul style="list-style-type: none"> • This command is used only in conjunction with a Step & Repeat command. • Two Fiducial Mark commands must be present in a program for the system to perform this adjustment function correctly. • Refer to “About Marks” on page 24 for more information on marks.

Appendix A, Command Function Reference (continued)

Fill Area									
Click	Function								
	Fills a defined area in a specific way using the specified Width and Band parameters. Refer to the explanations below this table for an example of each Fill Area type. NOTE: In any Fill Area command, the Z and R values for Line Start and Line End must match.								
	<table border="1"> <thead> <tr> <th>Parameter</th> <th>Description (see illustration examples)</th> </tr> </thead> <tbody> <tr> <td>Type (see below for an example of each)</td> <td> <ol style="list-style-type: none"> 1. Rectangle (S path) 2. Circle 3. Rectangle (outer to inner) 4. Rectangle Band 5. Circle Band 6. Rectangle (inner to outer) 7. Circle (inner to outer) </td> </tr> <tr> <td>Width</td> <td>The distance (in mm) between the center of the bead being dispensed and the bead that spirals next to it.</td> </tr> <tr> <td>Band</td> <td>The width (in mm) the completed fill must be (from one end to the other).</td> </tr> </tbody> </table>	Parameter	Description (see illustration examples)	Type (see below for an example of each)	<ol style="list-style-type: none"> 1. Rectangle (S path) 2. Circle 3. Rectangle (outer to inner) 4. Rectangle Band 5. Circle Band 6. Rectangle (inner to outer) 7. Circle (inner to outer) 	Width	The distance (in mm) between the center of the bead being dispensed and the bead that spirals next to it.	Band	The width (in mm) the completed fill must be (from one end to the other).
	Parameter	Description (see illustration examples)							
	Type (see below for an example of each)	<ol style="list-style-type: none"> 1. Rectangle (S path) 2. Circle 3. Rectangle (outer to inner) 4. Rectangle Band 5. Circle Band 6. Rectangle (inner to outer) 7. Circle (inner to outer) 							
Width	The distance (in mm) between the center of the bead being dispensed and the bead that spirals next to it.								
Band	The width (in mm) the completed fill must be (from one end to the other).								

Fill Area: 1. Rectangle (S path)

This command fills the defined area by passing the tip back and forth along the X axis (in an S-shaped path) at the specified Band distance while moving the Y axis the specified Width distance after each pass along the X axis. After entering a Fill Area Rectangle command, enter a Line Start point at the top left corner of the area to be filled and a Line End point at the bottom right corner of that area.

NOTE: In any Fill Area command, the Z and R values for Line Start and Line End must match.

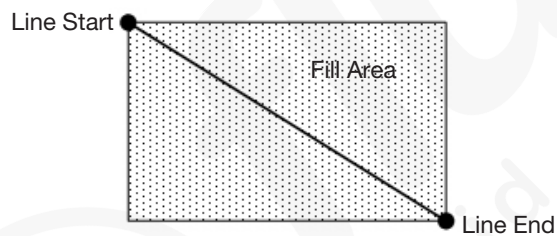

EXAMPLE: if a Width of 5 mm is entered, the tip makes the following path:

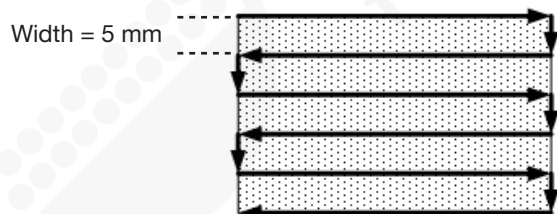

Appendix A, Command Function Reference (continued)

Fill Area: 2. Circle

This command fills the defined area by moving the tip along a spiral path from the outside of the circle to the center. After entering a Fill Area Circle command, jog the tip to a point on the outside limit of the circle to be filled and enter that location as a Line Start point. Then jog the tip directly across to the center of the circle and enter that location as a Line End point.

NOTE: In any Fill Area command, the Z and R values for Line Start and Line End must match.

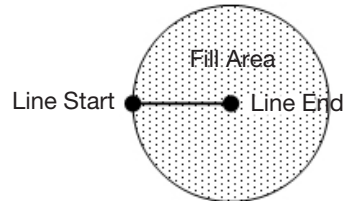

EXAMPLE: if a Width of 5 mm is entered, the tip makes the following path:

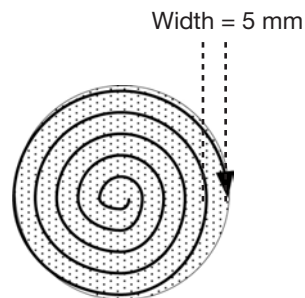

Fill Area: 3. Rectangle (Outer to Inner)

This command fills the defined area by moving the tip along a square, spiral-shaped path from the outside of the rectangle to the center. After entering a Fill Area Rectangle command, enter a Line Start point at the top left corner of the area to be filled and a Line End point at the bottom right corner of that area.

NOTE: In any Fill Area command, the Z and R values for Line Start and Line End must match.

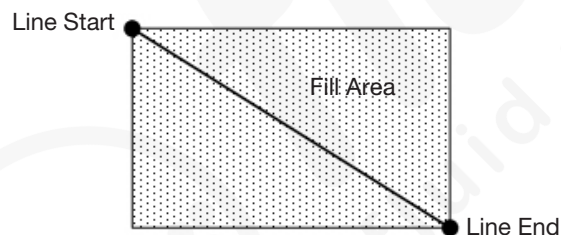

EXAMPLE: If a Width of 5 mm is entered, the tip makes the following path:

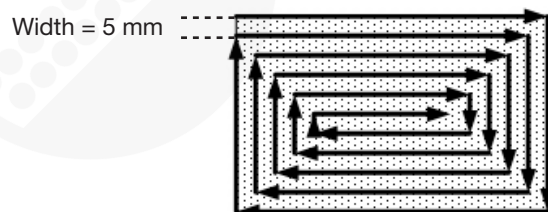

Appendix A, Command Function Reference (continued)

Fill Area: 4. Rectangle Band

This command fills a rectangular band area by moving the tip along a square, spiral-shaped path from the outside of the rectangle to the center. After entering a Fill Area Rectangle Band command, enter a Line Start point at the top left corner of the area to be filled and a Line End point at the bottom right corner of that area.

NOTE: In any Fill Area command, the Z and R values for Line Start and Line End must match.

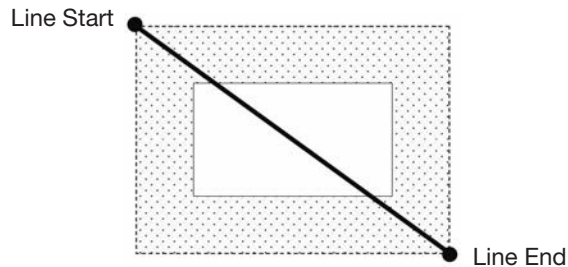

EXAMPLE: If a Width of 5 mm and a Band of 15 mm are entered, the tip makes the following path:

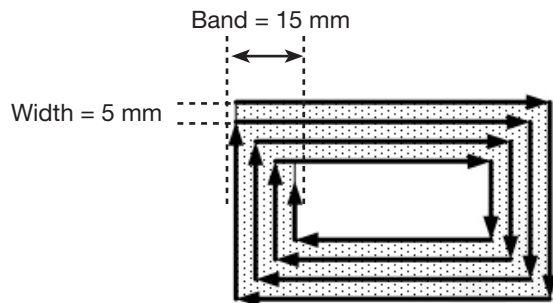

Fill Area: 5. Circle Band

This command fills a defined circular band area by moving the tip along a spiral path from the outside of the circle to the center. After entering a Fill Area Circle Band command, jog the tip to a point on the outside limit of the circle to be filled and enter that location as a Line Start point. Then jog the tip directly across to the center of the circle and enter that location as a Line End point.

NOTE: In any Fill Area command, the Z and R values for Line Start and Line End must match.

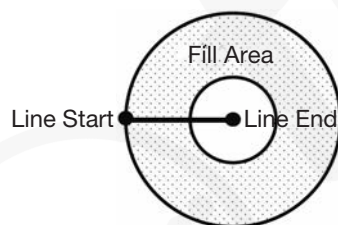

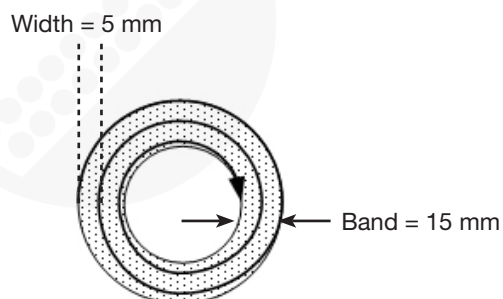

EXAMPLE: If a Width of 5 mm and a Band of 15 mm are entered, the tip makes the following path:



Appendix A, Command Function Reference (continued)

Find Angle Mark		
Click	Function	
Double-click address and select from drop-down menu	Used in tandem with Fiducial Marks to cause the system to search for a change in the XY orientation of a workpiece by searching in an angle-shaped area on the workpiece. If a change is found, the system adjusts the dispensing program accordingly. EXAMPLE: If Start Angle = 0 and End Angle = 90, the system searches for marks within the specified angle-shaped area. If a workpiece differs from the previous workpiece within that area, the system adjusts the dispensing program accordingly. If the system cannot find the marks within the specified angle-shaped area, it skips the workpiece.	
	Parameter	Description
	Start Angle	The angle (in degrees) at which the systems starts searching.
	End Angle	The angle (in degrees) at which the system stops searching.

Find Mark		
Click	Function	
	Causes the system to search for the mark specified in the No. (number) field of a Find Mark command. The mark is then used by the Mark Adjust command to adjust the dispensing program accordingly for any XY position changes between workpieces. NOTES:	
	<ul style="list-style-type: none"> • Only one Find Mark is required in a program for the system to perform this function correctly. • A Find Mark is different from a Fiducial Mark. A Find Mark is used only to check the XY position of a workpiece whereas a Fiducial Mark is used to check the orientation of a workpiece. • Refer to “About Marks” on page 24 for more information on marks. 	

Goto Address		
Click	Function	
	Causes the program to jump to the specified address.	

Goto Label		
Click	Function	
	Causes the program to jump to the address in the program that has the specified label.	

Appendix A, Command Function Reference (continued)

Height Sensor	
Click	Function
Double-click address and select from drop-down menu	Measures the height of an object on a workpiece where a dispense dot is to be placed; the measured data is then used to adjust dispensing accordingly for any height changes between workpieces. NOTE: This function is not currently available.

Initialize	
Click	Function
	Causes the robot to perform an initialization. The dispensing tip moves to the home position (0,0,0) and the robot relocates the home position using the home position sensors.

Input									
Click	Function								
	Causes the program to check for an input signal at the specified port and to turn the input ON or OFF.								
	<table border="1"> <thead> <tr> <th>Parameter</th> <th>Description</th> </tr> </thead> <tbody> <tr> <td>Port(1~8)</td> <td>Sets the input port number.</td> </tr> <tr> <td>0 Off, 1 On</td> <td>Turns the input OFF or ON.</td> </tr> <tr> <td>Address or Label</td> <td>Causes the program to check the input at the specified address or label. Click Change to toggle between Address and Label.</td> </tr> </tbody> </table>	Parameter	Description	Port(1~8)	Sets the input port number.	0 Off, 1 On	Turns the input OFF or ON.	Address or Label	Causes the program to check the input at the specified address or label. Click Change to toggle between Address and Label.
	Parameter	Description							
	Port(1~8)	Sets the input port number.							
0 Off, 1 On	Turns the input OFF or ON.								
Address or Label	Causes the program to check the input at the specified address or label. Click Change to toggle between Address and Label.								

Jet Step							
Click	Function						
Double-click address and select from drop-down menu	Used in tandem with two Dispense Dot commands to cause the system to dispense a stitched series of dots between the Dispense Dot commands at the specified length (Jet Step) and for the specified amount of time (Pulse Width). This command is useful for jetting applications in which extremely quick dispensing is required. NOTE: This command is not recommended for RV systems.						
	<table border="1"> <thead> <tr> <th>Parameter</th> <th>Description</th> </tr> </thead> <tbody> <tr> <td>Jet Step</td> <td>The distance (in mm) between the stitched dots deposited between two Dispense Dot commands.</td> </tr> <tr> <td>Pulse Width</td> <td>How long the dispenser stays open (in ms) for each dot deposited between two Dispense Dot commands.</td> </tr> </tbody> </table>	Parameter	Description	Jet Step	The distance (in mm) between the stitched dots deposited between two Dispense Dot commands.	Pulse Width	How long the dispenser stays open (in ms) for each dot deposited between two Dispense Dot commands.
Parameter	Description						
Jet Step	The distance (in mm) between the stitched dots deposited between two Dispense Dot commands.						
Pulse Width	How long the dispenser stays open (in ms) for each dot deposited between two Dispense Dot commands.						

Label	
Click	Function
	Registers a numeric label that can be used as a reference in the Goto Address, Goto Label, Loop Address, Step & Repeat X, Step & Repeat Y, and Call Subroutine commands. Using a Label is a good alternative to using an address number because a Label does not change when commands are inserted or removed. A maximum of 64 labels is allowed per program; each label can have up to 8 characters.

Appendix A, Command Function Reference (continued)

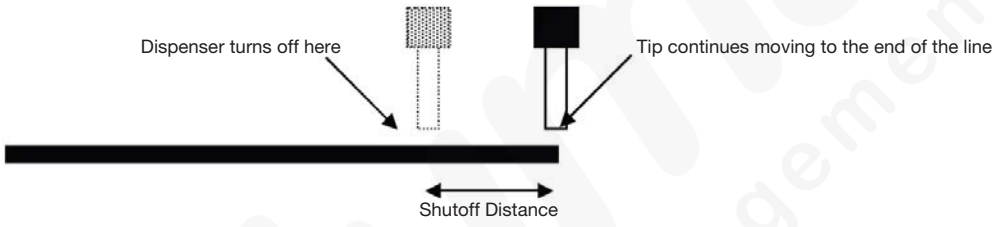
Line Dispense Setup		
Click	Function	
	Sets how the system dispenses a line of fluid. When dispensing high-viscosity fluids, there is often a delay between when the dispenser opens and when fluid begins to flow. Use the Line Dispense Setup parameters to compensate for this delay.	
	Parameter	Description
	Pre-move Delay	The time the dispenser stays open at the start of a line before moving. This delay time prevents the tip from moving along the line until fluid is flowing.
	Settling Distance	The distance the robot moves from the beginning of a Line Start before the dispenser turns on. This distance allows the robot sufficient time to build speed and is used primarily to eliminate the deposit of too much fluid at the beginning of a line.
	Dwell Time	Delay time that occurs at the end of a line after the dispenser closes to allow the pressure to equalize before the tip moves to the next point.
	Node Time	Delay time that occurs only for a Line Passing command. The dispensing tip passes through the Line Passing point and waits at the Line Passing point, with the dispenser activated, for the specified time period.
	Shutoff Distance	The distance before the end of a line when the dispenser closes to prevent excess fluid from being deposited at the end of the line, as shown in the illustration below.
	Shutoff Delay	The time the dispenser stays open after it stops at the end of a line.
 <p><i>Illustration of the Shutoff Distance parameter</i></p>		

Line End	
Click	Function
	Registers the current XYZR location as a Line End point. NOTE: The correct sequence of commands for a line is as follows: (1) Line Start, (2) Line Passing, (3) Line End.

Line Passing	
Click	Function
	Registers the current XYZR location as a Line Passing point. This is a location on a line where the dispensing tip changes direction, such as at the corner of a rectangle. NOTES: <ul style="list-style-type: none"> The correct sequence of commands for a line is as follows: (1) Line Start, (2) Line Passing, (3) Line End. Also use a Line Passing point before and after an Arc Point command.

Appendix A, Command Function Reference (continued)

Line Speed	
Click	Function
	Sets the speed (in mm/s) at which the dispensing tip travels at the location in the program where this command is inserted, thus overriding the default system line speed setting.

Line Start	
Click	Function
	Registers the current XYZR location as a Line Start point for line dispensing. NOTE: The correct sequence of commands for a line is as follows: (1) Line Start, (2) Line Passing, (3) Line End.

Loop Address		
Click	Function	
Double-click address and select from drop-down menu	Loops the program back to a specific Address (A) or Label for the number of times set for Count.	
	Parameter	Description
	Address	The Address (A) or Label number the program jumps to. The jump-to Address (A) or Label must occur before the current address.
	Count	The number of times to execute the loop.

Mark Adjust	
Click	Function
Double-click address and select from drop-down menu	When used in tandem with the Find Mark command, causes the system to search for the mark specified in the No. (number) field of the Find Mark command. When the system finds the mark, it checks the XY position of the workpiece and adjusts the dispensing path accordingly.

Multi Needle	
Click	Function
Double-click address and select from drop-down menu	In multiple dispenser installations, specifies the dispenser (called Needle Number) to execute the commands that follow this command. Currently up to five dispensers can be installed, so the Needle Number parameter can be 1-5. NOTE: For this function to operate correctly, the additional dispensers must be installed and set up. Refer to "Appendix E, Multi-Needle Setup and Use" on page 108.

Output		
Click	Function	
	Causes the program to send an output signal from the specified output port.	
	Parameter	Description
	Port(1~8)	Sets the output port number.
	0 Off, 1 On	Turns the output OFF or ON.

Appendix A, Command Function Reference (continued)

Park Position	
Click	Function
	Moves the dispensing tip to the park position specified by the Park Position settings on the System Setup screen.

Ptp (Point to point) Speed	
Click	Function
Double-click address and select from drop-down menu	Sets the acceleration (as a percentage) of the robot from point to point at the location in the program where this command is inserted, thus overriding the default system point-to-point speed setting.

QA Capture	
Click	Function
Double-click address and select from drop-down menu	Saves the image seen by the camera at the XYZR coordinates specified for the command. Images are saved under D:\ever_sr\history. Each time a QA Capture command is executed, the system creates a subdirectory (under D:\ever_sr\history) that is named for the day the command was executed. The file path for the saved QA images is: D:\ever_sr\history \eXXXX_YY\QAIimage_ZZ, where XXXX = year, YY = month, and ZZ = day of month

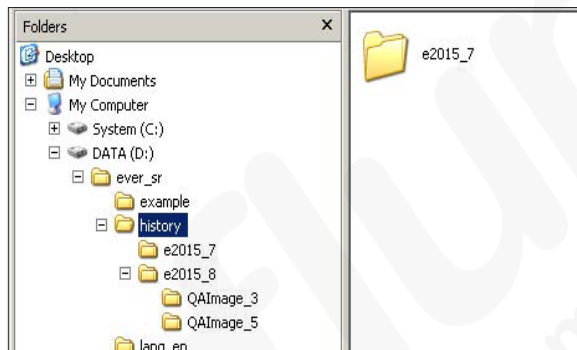

Directory structure created by the QA Capture command

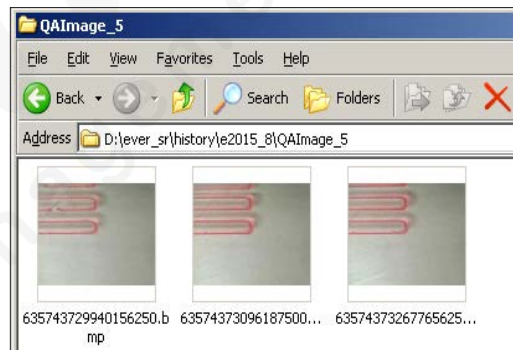

Example of saved QA Capture images

Rectangle Adjust	
Click	Function
Double-click address and select from drop-down menu	This command is not used on RV Series systems.

Setup Dispense Port	
Click	Function
Double-click address and select from drop-down menu	Allows you to turn on multiple output ports at the same time. For example, to turn on ports 1, 2, and 3, enter "1.2.3" (with periods between the port numbers, no spaces). The default setting is port 0.

Appendix A, Command Function Reference (continued)

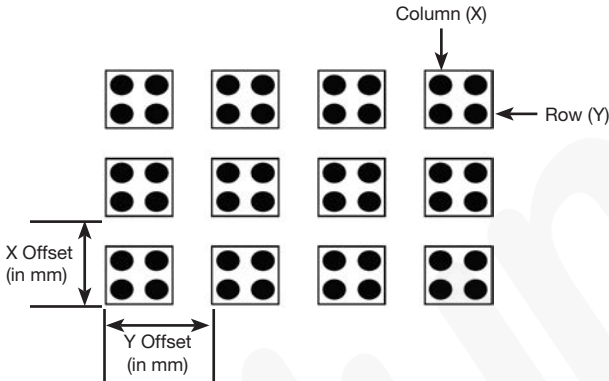
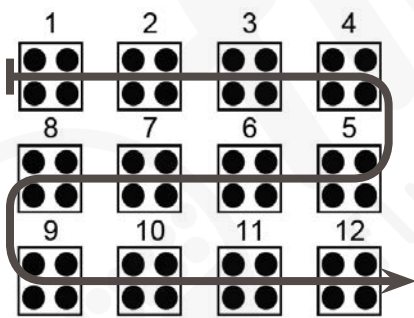
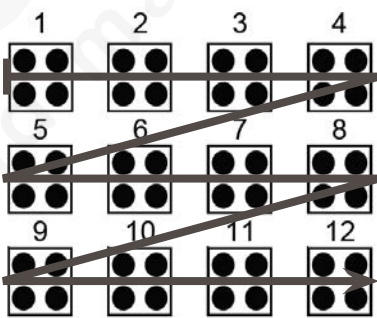
Step & Repeat X		
Click	Function	
	Enables the repeat of the dispensing pattern onto many identical workpieces that are mounted on a fixture and aligned in rows and columns.	
	Parameter	Description (see illustrations below)
	X Offset	The distance (in mm) between each workpiece in the X direction.
	Y Offset	The distance (in mm) between each workpiece in the Y direction.
	Columns (X)	The number of columns in the X direction.
	Rows (Y)	The number of rows in the Y direction.
	1.S Path or 2.N Path	The path of pattern travel. Select "1.S Path" for an S-shaped pattern or "2.N Path" for an N-shaped pattern.
	Label (default) or Address	The label or address where the Step & Repeat X command begins.
 <p>Example of X and Y offsets in a Step & Repeat command</p>		
<div style="display: flex; justify-content: space-around;"> <div style="text-align: center;"> <p>Step & Repeat X, S Path</p>  </div> <div style="text-align: center;"> <p>Step & Repeat X, N Path</p>  </div> </div> <p>Difference between the "1.S Path" and "2.N Path" selections</p>		

Appendix A, Command Function Reference (continued)

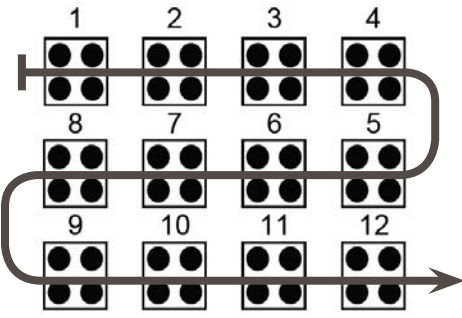
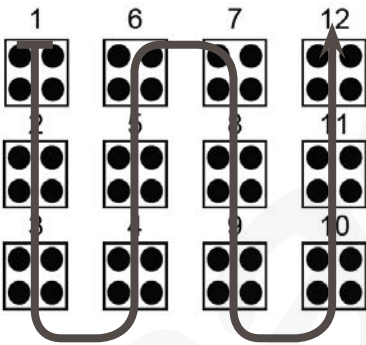
Step & Repeat Y	
Click	Function
	Works exactly like Step & Repeat X except that priority is given to the Y axis instead of to the X axis, as shown below.
<div style="display: flex; justify-content: space-around;"> <div style="text-align: center;"> <p>Step & Repeat, X Axis Direction</p>  </div> <div style="text-align: center;"> <p>Step & Repeat, Y Axis Direction</p>  </div> </div> <p><i>Difference between Step & Repeat X and Step & Repeat Y</i></p>	

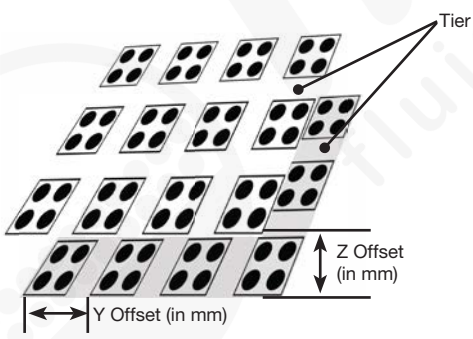
Step & Repeat Z									
Click	Function								
Double-click address and select from drop-down menu	Enables the repeat of the dispensing pattern onto many identical workpieces that are mounted on a fixture plate and aligned in rows and columns.								
	<table border="1"> <thead> <tr> <th>Parameter</th> <th>Description</th> </tr> </thead> <tbody> <tr> <td>Z Offset</td> <td>The distance (in mm) between each workpiece tier in the Z direction. Range: 0.1–100 (mm)</td> </tr> <tr> <td>Tier</td> <td>The number of tiers in the Z direction: <ul style="list-style-type: none"> • A positive Z value moves the tip down towards the work surface. • A negative Z value moves the tip up away from the work surface. Range: 1–9999 </td> </tr> <tr> <td>Label</td> <td>The address where the Step & Repeat Z command begins.</td> </tr> </tbody> </table>	Parameter	Description	Z Offset	The distance (in mm) between each workpiece tier in the Z direction. Range: 0.1–100 (mm)	Tier	The number of tiers in the Z direction: <ul style="list-style-type: none"> • A positive Z value moves the tip down towards the work surface. • A negative Z value moves the tip up away from the work surface. Range: 1–9999	Label	The address where the Step & Repeat Z command begins.
	Parameter	Description							
	Z Offset	The distance (in mm) between each workpiece tier in the Z direction. Range: 0.1–100 (mm)							
Tier	The number of tiers in the Z direction: <ul style="list-style-type: none"> • A positive Z value moves the tip down towards the work surface. • A negative Z value moves the tip up away from the work surface. Range: 1–9999								
Label	The address where the Step & Repeat Z command begins.								
									
<p><i>Diagram of the Z Offset and Tier Parameters</i></p>									

Appendix A, Command Function Reference (continued)

Stop Point	
Click	Function
	Registers a Stop Point at the current XYZR location. When this command occurs, the dispensing tip moves to the registered location and waits until the START button is pressed.

Trig Mark	
Click	Function
Double-click address and select from drop-down menu	This command is not used on RV Series systems.

Wait Point	
Click	Function
	Registers a Wait Point to occur immediately after the previous command. When this command occurs, the dispensing tip waits at the end point of the previous command for the specified Wait Time (in seconds).

Z Clearance Setup	
Click	Function
	<p>Specifies the height to which the dispensing tip raises after each dispense command. The purpose of Z Clearance is to raise the tip high enough so that it clears all obstacles as it moves from one point to another. If there are no obstacles between any of the points, a small Z Clearance value, such as 5 mm, can be used to minimize the program cycle time.</p> <p>Z Clearance is further defined as an absolute value (0) or a relative value (1). When specified as a relative value, it is the distance the tip raises relative to the taught point location. When it is specified as an absolute value, it is the distance from the Z axis zero position to which the tip raises regardless of the Z-axis value of the taught point location.</p> <p>Nordson EFD recommends inserting a Z Clearance command at the beginning of a program.</p>
Parameter	Description (see illustrations below)
Value	The distance (in mm) the tip raises after dispensing.
0(Abs), 1(Rel)	How the tip raises: 0(Abs) = absolute, 1(Rel) = relative.

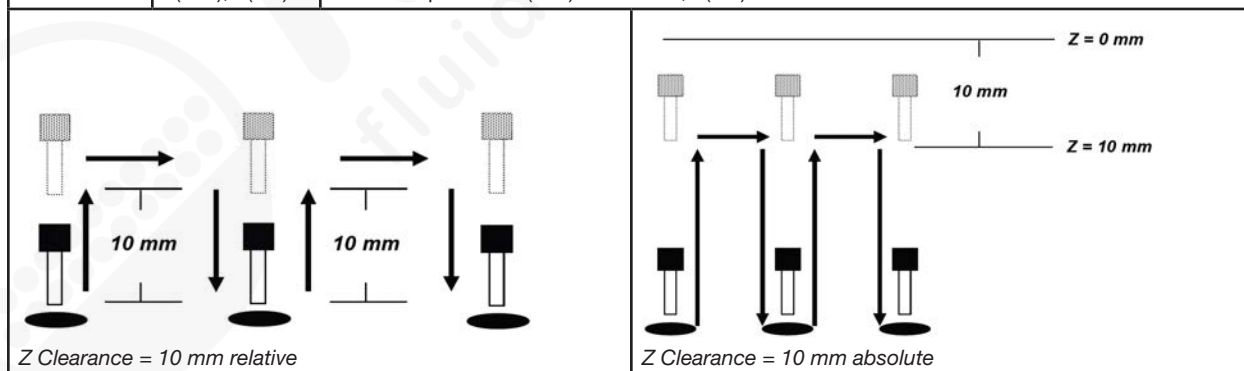







Appendix B, Non-Wizard Setup Procedures

All setup and calibration procedures are guided by the Robot Initial Setup wizard, which should be used after any system change, including tip change-out. However, the procedures in this appendix can be performed individually and are provided here for your reference as needed.

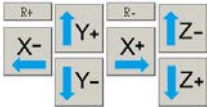
Setting the Camera Scale







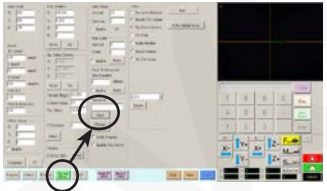
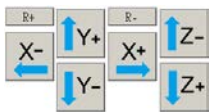

PREREQUISITES

- ❑ The system is fully installed (including the dispensing valve) and includes fluid.
- ❑ The bottom of the tip is lower than the bottom of the camera.
- ❑ The workpiece is present on the fixture plate.

#	Click	Step	Reference Image
1		<ul style="list-style-type: none"> • Click the CAMERA tab. 	
2		<ul style="list-style-type: none"> • Jog the camera to a point of reference that is located on the lower right corner of the workpiece. • Bring the image into focus. Refer to “Camera” on page 16 as needed for instructions on focusing the camera. 	
3	 > 	<ul style="list-style-type: none"> • Click the CAMERA tab and then click SCALE. <p>The Scale window opens.</p> <p>NOTE: When the camera views an object, it converts the pixels to a true measurement. For the camera to make this conversion accurately, you must “teach” the camera what the size of an object is in comparison to pixels per inch by setting the camera scale.</p>	
4		<ul style="list-style-type: none"> • Choose a point of reference on the workpiece and jog the camera so that the reference point is located in the lower right quadrant of the camera screen, then click the point. 	
5		<ul style="list-style-type: none"> • Jog the camera again until the same reference point is located in the upper left quadrant of the camera screen, then click the point. <p>The camera scale is now set.</p>	

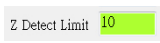





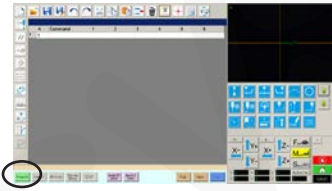

Appendix B, Non-Wizard Setup Procedures (continued)

Setting Up the Optional Tip Detector or Tip Alignment Device

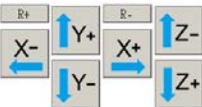
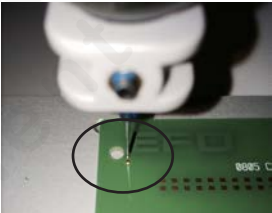
#	Click	Step	Reference Image
1		<ul style="list-style-type: none"> Click SYSTEM SETUP > OPEN. 	
2		<ul style="list-style-type: none"> Jog the tip until it is positioned about 2 mm above the sensor on the tip detector or the crosshairs on the tip alignment device. 	<div style="display: flex; justify-content: space-around;"> <div style="text-align: center;">  <p><i>Sensor on the optional tip detector</i></p> </div> <div style="text-align: center;">  <p><i>Crosshairs on the optional tip alignment kit</i></p> </div> </div>
3		<ul style="list-style-type: none"> Under Tip Detect Device, click SET (next to Move). Click YES/OK when prompted for confirmations. 	
4		<ul style="list-style-type: none"> Under Tip Detect Device, enter a value of 10 (mm) Z Detect Limit. Click YES/OK when prompted for confirmations. 	
5		<ul style="list-style-type: none"> Under Tip Detect Device, click DETECT. Click YES/OK when prompted for confirmations. <p>The robot raises the tip to Z = 0, then lowers the tip onto the sensor to detect the tip offset.</p>	

Appendix B, Non-Wizard Setup Procedures (continued)

Setting the Tip-to-Workpiece Offset (Z Clearance) Using the Camera Focus

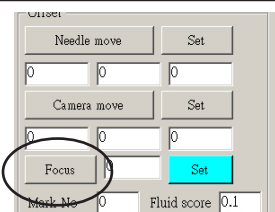
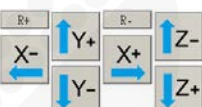
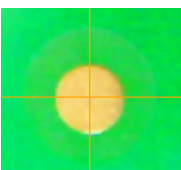





#	Click	Step	Reference Image
1		<ul style="list-style-type: none"> Click the PROGRAM tab. 	
2		<ul style="list-style-type: none"> Click the CCD Mode icon to change to the Tip MODE. 	
3		<ul style="list-style-type: none"> Jog the tip to a good reference point on the workpiece. 	
4		<ul style="list-style-type: none"> Jog the tip down until it is as close to the workpiece as possible without touching the surface. 	
5		<ul style="list-style-type: none"> Click CAMERA > SETUP to return to the Offset fields. 	
6		<ul style="list-style-type: none"> Click SET next to Focus. <p>NOTE: The Set button should be bright blue.</p>	
7		<ul style="list-style-type: none"> Click FOCUS next to Set. 	
8		<ul style="list-style-type: none"> Jog the camera until the camera crosshairs are centered over the dispense dot you created earlier. Focus the camera until the image of the dispense dot is clear. Refer to "Camera" on page 16 as needed for instructions on focusing the camera. 	

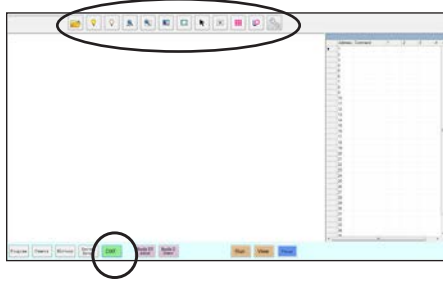





Appendix C, DXF File Import

This appendix provides an overview of the DXF screen components and the procedure for importing DXF files.

Overview of the DXF Screen



Icon Name	Icon	Function
Open a File		Opens a file
Show All Layers		Shows all layers of the open DXF file
Hide All Layers		Hides all layers of the open DXF file
See All		Compresses or resizes the display so that all points of the open DXF file are displayed in the viewing area of the screen
Zoom		Zooms to the selected area
Select All		Selects all the points in the DXF file

Icon Name	Icon	Function
Range of Select		Selects only the points within the area of the rectangle
Select Directly		Selects one element
Cancel Select		Cancel any selections
Point Dispense		Inserts Dispense Dot commands for all the selected points on an imported DXF image
Line Dispense		Inserts line dispense commands for all the selected shapes on an imported DXF image
Option		Refer to "Setting DXF Import Preferences" on page 101.

Appendix C, DXF File Import (continued)

Setting DXF Import Preferences

Click the OPTION icon on the DXF screen to set DXF import preferences.

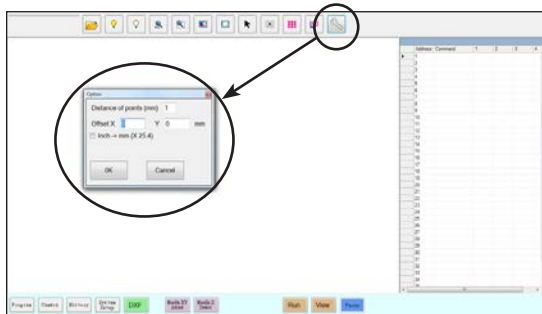









Item	Description
Distance of points (mm)	Specifies the distance between any two points on a curve when the curve is converted to coordinates. For example, when this value is set to 1 and a 10-mm long curve is converted to commands, the result will be a series of Line Start, Line Passing, and Line End commands that will produce a curve with a total of 11 points.
Offset X, Y	After you create program commands using Point Dispense or Line Dispense, the resulting XY values may be negative numbers. This causes the imported points to display off the grid when viewed on the Secondary View screen. To resolve this issue, enter X and / or Y values in the offset fields of the Option window such that the imported XY values change to positive values. For example, if an imported XY value is -150, -150, 0, then enter 200 for Offset X and 200 for offset Y, click OK, and then click the Point Dispense or Line Dispense icon again to refresh the values. The new values will be 50, 50, 0 and the points will be visible on the Secondary View screen grid when you go to the Program screen.
Inch > mm (X 25.4)	Toggles the display of units between metric and English. Check if you want to display units in mm.

Appendix C, DXF File Import (continued)

Importing a DXF File

PREREQUISITES



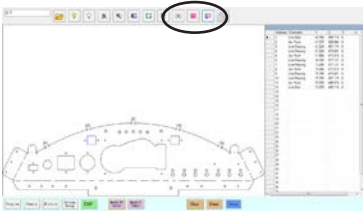

- ❑ The system is properly set up. Refer to “Setting Up and Calibrating the System (Required)” on page 40.
- ❑ If the tip or any element of the Z axis head was changed, repeat system setup and calibration using the Robot Initial Setup wizard. Refer to “Setting Up the System Using the Robot Initial Setup Wizard” on page 43.
- ❑ The system is in the correct mode (Tip or CCD).
- ❑ The DXF file for the workpiece is located on the DispenseMotion controller.
- ❑ The actual workpiece is properly positioned on the fixture plate.

#	Click	Step	Reference Image
1		<ul style="list-style-type: none"> • Click DXF. <p>The DXF screen appears in the Primary View screen.</p>	
2		<ul style="list-style-type: none"> • Open the DXF file you want to convert to a program. <p>The file appears in the Primary View screen.</p>	
3	 or 	<ul style="list-style-type: none"> • To hide or show layers, click HIDE ALL LAYERS or SHOW ALL LAYERS. 	
4		<ul style="list-style-type: none"> • Select the points and / or lines onto which you want to dispense material. Refer to “Overview of the DXF Screen” on page 100 for an explanation of all the selection icons. 	
5	 or 	<ul style="list-style-type: none"> • Click POINT DISPENSE (for dispense dots) or LINE DISPENSE (for lines, arcs, and circles). <p>The system generates the program commands that will create the selected pattern.</p>	

Continued on next page

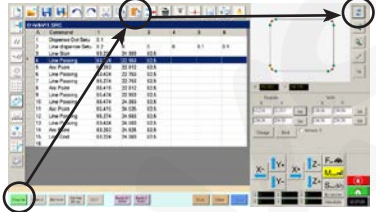
Appendix C, DXF File Import (continued)

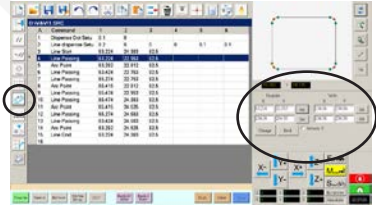

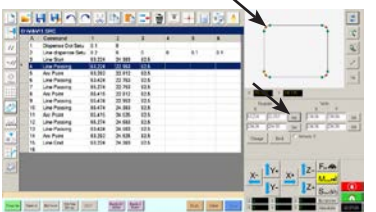
Importing a DXF File (continued)

#	Click	Step	Reference Image
6		<ul style="list-style-type: none"> Click the PROGRAM tab, select an empty Address line, then click PASTE. <p>The commands appear in the Program screen.</p>	
7		<ul style="list-style-type: none"> Click REFRESH next to the Secondary View screen to show the imported points and lines and make changes as needed to the program. <p>The next step is to match the program commands to the actual workpiece.</p>	
<p>NOTES:</p> <ul style="list-style-type: none"> After making any change to the program, click REFRESH to update the view in the Secondary View screen to show the changes. You may need to zoom out to see the points. This can be avoided by entering offset values in the DXF screen Option window. Refer to Option X, Y under "Setting DXF Import Preferences" on page 101. 			
8		<ul style="list-style-type: none"> Click TRANSFORM. <p>The Program and Table fields appear.</p>	
9		<ul style="list-style-type: none"> Click on a point at the far left side of the points shown in the Secondary View screen, then click the top SET button under Program. 	

Continued on next page

Appendix C, DXF File Import (continued)

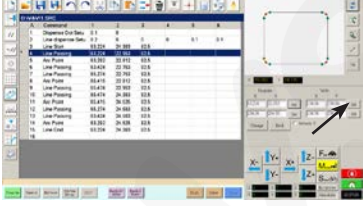
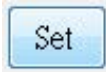
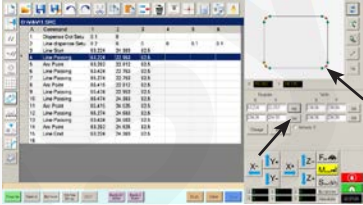
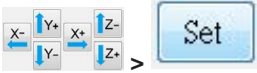
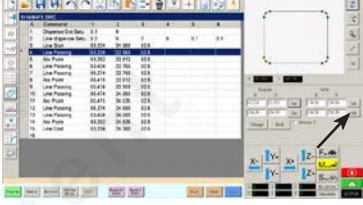
Importing a DXF File (continued)

#	Click	Step	Reference Image
10		<ul style="list-style-type: none"> Jog the tip to the same point on the actual workpiece and then click the top SET button under Table. 	
11		<ul style="list-style-type: none"> Click on a point at the far right side of the points shown in the Secondary View screen, then click the bottom SET button under Program. 	
12		<ul style="list-style-type: none"> Jog the tip to the same point on the actual workpiece and then click the bottom SET button under Table. 	
13		<ul style="list-style-type: none"> Click CHANGE. The system updates all XY locations in the program so they align with same XY locations on the actual workpiece. 	







Appendix D, QR Code Scanning Setup

Programs can be executed using a QR code scan. For the system to execute a program using a QR code, the following must occur:

- A QR code for the workpiece must be present on the robot fixture plate surface (for example, on the workpiece itself or on the workpiece fixture).
- QR code scanning must be enabled and each QR code must be associated with a program. Refer to the procedure below.

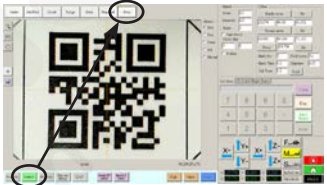
NOTE: Bar codes are not supported.

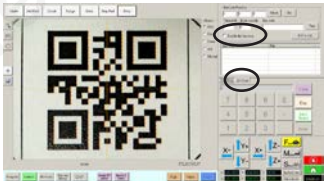
To Enable QR Code Scanning

#	Click	Step	Reference Image
1	 > 	<ul style="list-style-type: none"> • Click the SYSTEM SETUP tab, then click OPEN. 	
2	<input checked="" type="checkbox"/> 2D Code	<ul style="list-style-type: none"> • Check 2D CODE to enable QR code scanning. 	
3	 > 	<ul style="list-style-type: none"> • Click the CAMERA tab and then click SETUP at the top of the Camera screen. The camera setup fields appear. 	
4	 > <input checked="" type="checkbox"/> Enable the function	<ul style="list-style-type: none"> • Click the 2D CODE tab to open the code setup fields, then check ENABLE THE FUNCTION. 	

Appendix D, QR Code Scanning Setup (continued)



To Associate a QR Code with a Program

#	Click	Step	Reference Image
1		<ul style="list-style-type: none"> • Jog the camera until it is centered over the QR code you want to associate with a program. 	
2		<ul style="list-style-type: none"> • Click SET to record the location. <p>The QR code location coordinates appear in the BarCode Position fields.</p>	
3		<ul style="list-style-type: none"> • With the QR code in view and in focus, click TEST to scan the QR code. <p>If the system cannot identify the QR code, the Nan pop-up window appears.</p>	
4		<ul style="list-style-type: none"> • Adjust the THRESHOLD and EDGE SMOOTH values: <ul style="list-style-type: none"> - THRESHOLD: Range = 0–255 - EDGE SMOOTH: Range = 0–5 	
5		<ul style="list-style-type: none"> • Click TEST again. <p>When the system properly identifies the QR code, a window like the one at right appears.</p> <ul style="list-style-type: none"> • Repeat steps 4 and 5 until the system recognizes the QR code. After the QR code is recognized, continue with the next steps to associate it with a program. 	
6		<ul style="list-style-type: none"> • Click ADD TO LIST. <p>The Open file window appears.</p>	
7		<ul style="list-style-type: none"> • Select the dispense program to associate with the QR code, the click OPEN. <p>The dispense program is now associated with the QR code.</p>	

Continued on next page

Appendix D, QR Code Scanning Setup (continued)

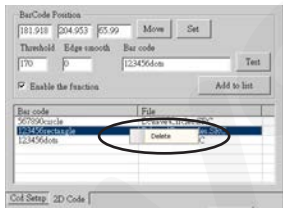
To Associate a QR Code with a Program (continued)

#	Click	Step	Reference Image
8		<ul style="list-style-type: none"> Continue to add additional QR codes as needed. To remove a QR code, right-click on the QR code and then click DELETE. 	
9	 	<ul style="list-style-type: none"> Return to PROGRAM screen and then click RUN to test the program. <p>The system finds the QR code, scans it, opens the associated program, and executes the program.</p>	Refer to the screen captures .

The system is now set up for QR code scanning. Refer to "Running a Program by Scanning a QR Code" on page 71 for an operating procedure.

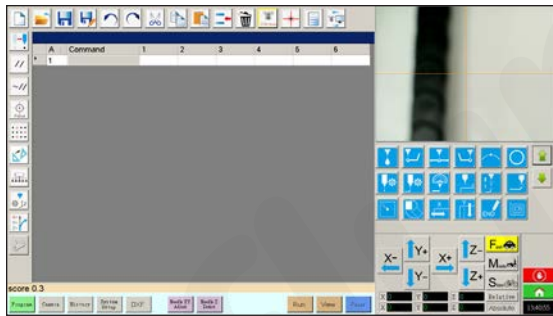

1. Clicking PROGRAM and then RUN to test the program.

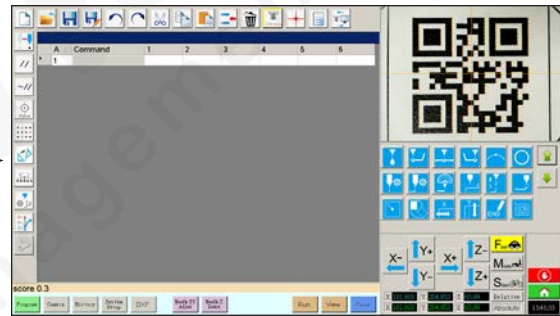

2. The system moves to the QR code and scans it.

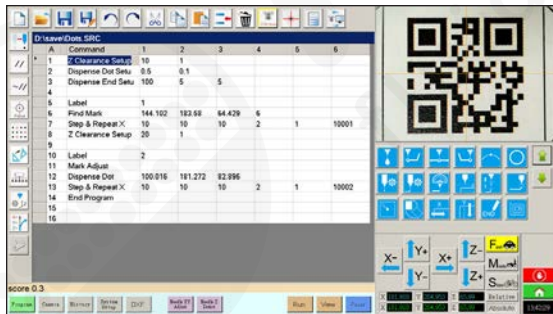

The system opens the program and executes it.

Appendix E, Multi-Needle Setup and Use

A multi-dispenser bracket can be installed on the Z axis to accommodate up to five dispensers. When more than one dispenser is installed, the camera-to-tip offset must be set for each dispenser. After the system is set up for multi-needle operation, you can insert the Multi Needle dispense command to specify which dispenser executes the commands that follow the Multi-Needle command.

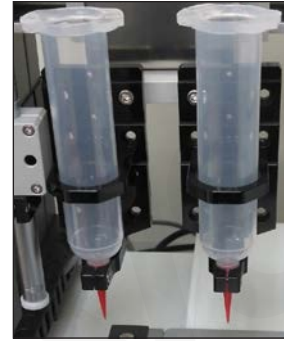

NOTE: For contact dispensing applications with multiple dispensers, an additional toggle assembly is required for the multi-dispenser bracket.



PREREQUISITES

- ❑ The required additional dispensers are installed on the robot. Contact your Nordson EFD representative for assistance as needed.
- ❑ The system is properly set up. Refer to “Setting Up and Calibrating the System (Required)” on page 40.
- ❑ A test workpiece is positioned on the fixture plate or work surface.

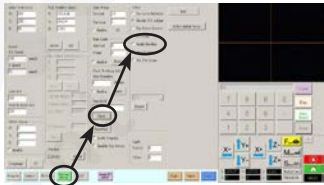
To Enable Multi-Needles Dispensing

#	Click	Step	Reference Image
1		<ul style="list-style-type: none"> • Click the SYSTEM SETUP tab, then click OPEN. 	
2		<ul style="list-style-type: none"> • Check MULTI NEEDLES. 	

To Set the Camera-to-Tip Offsets for Multiple Dispensers



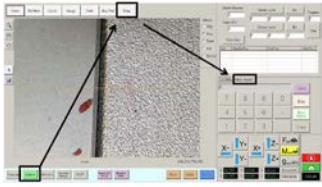
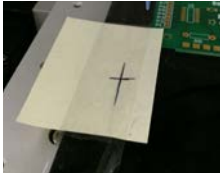





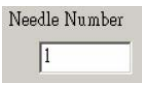
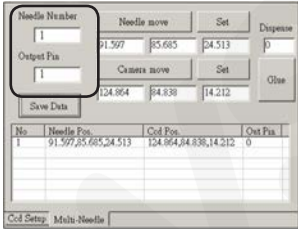

NOTE: This procedure explains the setup process for two dispensers. Repeat steps as needed to set up the system for additional dispensers (up to five dispensers can be installed).

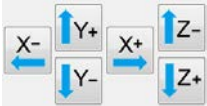
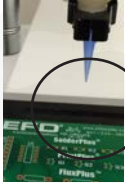
#	Click	Step	Reference Image
1		<ul style="list-style-type: none"> • Click the CAMERA tab, click SETUP at the top of the Camera screen, and then click the MULTI-NEEDLE tab. The Multi Needle fields appear. 	
2		<ul style="list-style-type: none"> • If your system does not include the tip detector, create a crosshair target point close to the workpiece. 	

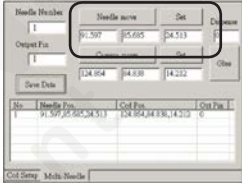
Continued on next page

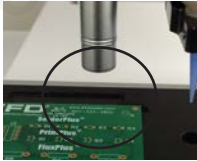
Appendix E, Multi-Needle Setup and Use (continued)

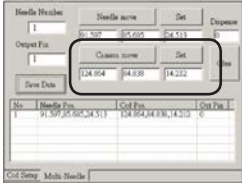

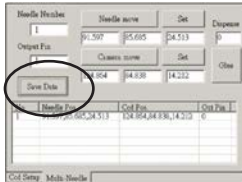



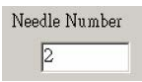
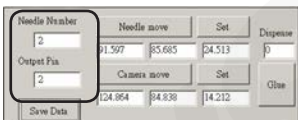

To Set the Camera-to-Tip Offsets for Multiple Dispensers (continued)

#	Click	Step	Reference Image
3		<ul style="list-style-type: none"> Click inside the NEEDLE NUMBER field and enter the dispenser number (in this example, Needle Number 1 for Dispenser 1). 	
4		<ul style="list-style-type: none"> Click inside the OUTPUT PIN field and enter the I/O Port pin that the dispenser is connected to (in this example, 1 for Dispenser 1). 	
5		<ul style="list-style-type: none"> Use the jog keys to position the tip over the crosshair target (on either the tip detector or the one you created). Jog the tip down until it is as close to the crosshair target as possible without touching the target. 	
6		<ul style="list-style-type: none"> Click SET next to Needle Move. <p>This sets the XYZR coordinates for the dispense calibration point. The system enters the dispensing tip coordinates in the fields under Needle Move and Set.</p>	
7		<ul style="list-style-type: none"> Jog the camera until the camera crosshairs are centered over the crosshair target, then focus the camera until the image of the crosshair target is clear. 	
8		<ul style="list-style-type: none"> Click SET next to Camera Move. <p>This sets the camera position. The system enters the camera coordinates in the fields under Camera Move and Set.</p>	
9		<ul style="list-style-type: none"> Click SAVE DATA. <p>The system populates the Needle 1 data fields.</p>	

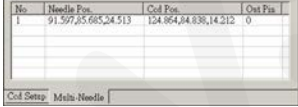
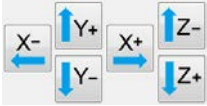
Continued on next page

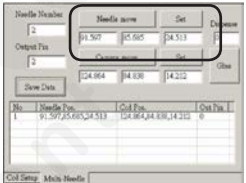
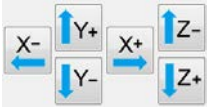
Appendix E, Multi-Needle Setup and Use (continued)

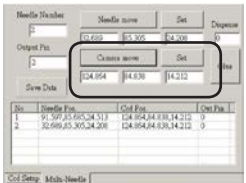
To Set the Camera-to-Tip Offsets for Multiple Dispensers (continued)

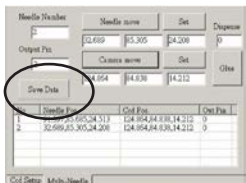
#	Click	Step	Reference Image
10		<ul style="list-style-type: none"> Click inside the NEEDLE NUMBER field and enter the number for the second dispenser (in this example, Needle Number 2 for Dispenser 2). 	
11		<ul style="list-style-type: none"> Click inside the OUTPUT PIN field and enter the I/O Port pin that the second dispenser is connected to (in this example, 2 for Dispenser 2). 	
12		<ul style="list-style-type: none"> Use the jog keys to position the second tip over the crosshair target (on either the tip detector or the one you created). Jog the tip down until it is as close to the crosshair target as possible without touching the target. 	
13		<ul style="list-style-type: none"> Click SET next to Needle Move. <p>This sets the XYZR coordinates for the dispense calibration point. The system enters the dispensing tip coordinates in the fields under Needle Move and Set.</p>	
14		<ul style="list-style-type: none"> Jog the camera until the camera crosshairs are centered over the crosshair target and then focus the camera until the image of the crosshair target is clear. 	
15		<ul style="list-style-type: none"> Click SET next to Camera Move. <p>This sets the camera position. The system enters the camera coordinates in the fields under Camera Move and Set.</p>	
16		<ul style="list-style-type: none"> Click SAVE DATA. <p>The system populates the Needle 2 data fields.</p>	

The system is now set up for multiple dispenser operation. Continue to the next procedure in this section to use this capability.







Appendix E, Multi-Needle Setup and Use (continued)

To Use the Multi Needle Command in a Program

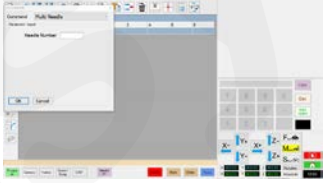
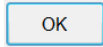
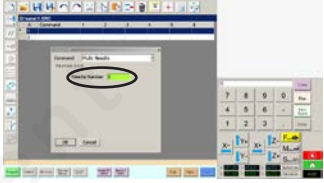
PREREQUISITES

- ❑ The system is properly set up. Refer to “Setting Up and Calibrating the System (Required)” on page 40.
- ❑ The additional dispensers are installed and set up and the Multi Needle capability is enabled. Refer to “To Enable Multi-Needles Dispensing” on page 108 and to “To Set the Camera-to-Tip Offsets for Multiple Dispensers” on page 108.
- ❑ A test workpiece is positioned on the fixture plate or work surface.

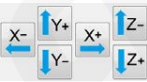
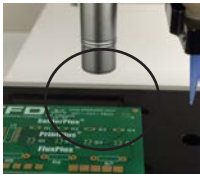
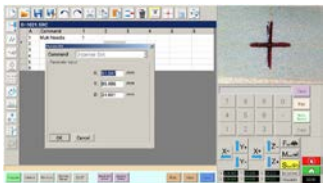





NOTE: This procedure explains the programming process for two dispensers. Repeat steps as needed to add commands for additional dispensers (up to five dispensers can be installed).

#	Click	Step	Reference Image
1	 > MULTI NEEDLE	<ul style="list-style-type: none"> • Click the PROGRAM tab • Double-click the address row where you want to insert a Multi Needle command and select MULTI NEEDLE. 	
2	1 > 	<ul style="list-style-type: none"> • Enter the number of the dispenser to dispense from at this point in the program (in this example, Dispenser 1). • Click OK to save. 	
3		<ul style="list-style-type: none"> • In the Secondary View screen, right click and check the NEEDLE 1 checkbox. 	
4	 > 	<ul style="list-style-type: none"> • Click the FOCUS icon to focus the camera. • Jog the camera until the camera crosshairs are centered over the desired target on the workpiece. 	
5		<ul style="list-style-type: none"> • Enter the required commands for Dispenser 1 (for example, create dispense dots or lines). 	
6	MULTI NEEDLE	<ul style="list-style-type: none"> • Double-click the address row where you want to insert the second Multi Needle command and select MULTI NEEDLE. 	

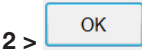
Continued on next page

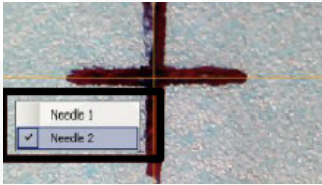
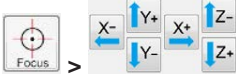
Appendix E, Multi-Needle Setup and Use (continued)

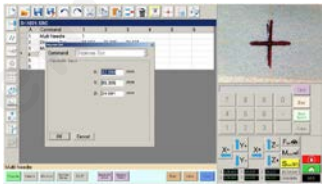
To Use the Multi Needle Command in a Program (continued)

#	Click	Step	Reference Image
7		<ul style="list-style-type: none"> Enter the number of the dispenser to dispense from at this point in the program (in this example, Dispenser 2). Click OK to save. 	
8		<ul style="list-style-type: none"> In the Secondary View screen, right click and check the NEEDLE 2 checkbox. 	
9		<ul style="list-style-type: none"> Click the FOCUS icon to focus the camera. Jog the camera until the camera crosshairs are centered over the desired target on the workpiece. 	
10		<ul style="list-style-type: none"> Enter the required commands for Dispenser 2 (for example, create arc or fills). 	
11		<ul style="list-style-type: none"> Click END PROGRAM to end the program. The system will dispense from Dispenser 1 or Dispenser 2 as programmed. 	

Appendix F, I/O Pin Function Setup

The I/O Pin Function capability, accessed through the Expert menu on the System Setup screen, provides a set of user-configurable conditions that can be assigned to the available inputs and outputs on the I/O Port. These conditions affect the operation of the robot.

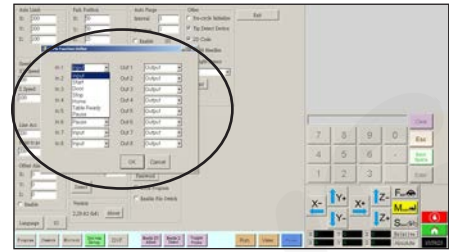

IO Pin Function Configurations

Input Configuration	Description
Input	Default setting.
Start	A signal to start the execution of the dispense program.
Door	A signal to stop the execution of the dispense program. This configuration is to be used in tandem with the DOOR OPEN output configuration.
Stop	A signal to stop the execution of the dispense program.
Home	A signal to home/reinitialize the robot after a stop of the dispense program.
Table Ready	A signal to indicate that the system is ready to execute the dispense program. The dispense program will not execute if the input signal is off. This configuration is to be used in tandem with the TABLE READY output configuration.
Pause	A signal to pause the execution of the dispense program.
Call Program	A signal to initiate a different program. Use the Call Program selection from the Expert menu to specify the program to call.





Output Configuration	Description
Output	Default setting.
Emergency	A signal indicating that the robot has stopped.
EMG-B	A signal indicating that the Emergency Stop button on the robot is pressed.
Running	A signal indicating that the dispense program is currently executing.
Homing	A signal indicating that the robot is reinitializing/moving to home position.
Standby	A signal indicating that the robot is in a standby (idle) position.
Pause	A signal indicating that the dispense program is paused.
System Start	A signal indicating that the DispenseMotion software is open and running.
Table Ready	A signal indicating that the system is ready to execute the dispense program. This configuration is to be used in tandem with the TABLE READY input configuration.
Door Open	A signal indicating that the door is open. This configuration is to be used in tandem with the DOOR input setting.
No Start Trigger	A signal indicating that the program cannot run until the TABLE READY input signal is ON. When the TABLE READY input is ON, the NO START TRIGGER indication switches OFF. This configuration must be used with the TABLE READY input and the TABLE READY output configurations.
Teach Mode	A signal indicating that the robot is in the Teach mode. This signal can be used when the external start / stop box is present.
Calibration Execution	A signal indicating that the robot is performing a Needle Z Detect or a Needle XY Adjust.
Positional Error	A signal indicating an over-limit warning after a general over-limit warning from program execution occurs.
In Home	A signal indicating that the tip is in the Park Position.

Appendix F, I/O Pin Function Setup (continued)

To Reconfigure Inputs / Outputs

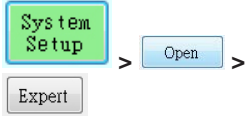
PREREQUISITES

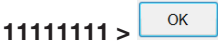
- The system is properly set up. Refer to “Setting Up and Calibrating the System (Required)” on page 40.

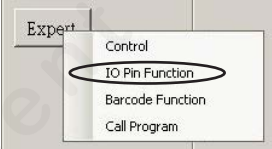
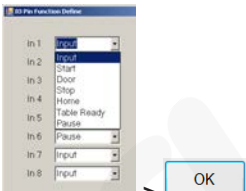
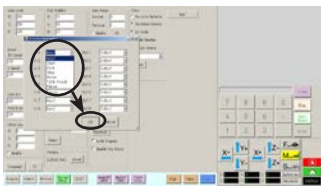
#	Click	Step	Reference Image
1		<ul style="list-style-type: none"> • Connect the signal wiring to the I/O Port on the back of the robot. 	
2		<ul style="list-style-type: none"> • Click SYSTEM SETUP > OPEN > EXPERT. 	
3		<ul style="list-style-type: none"> • Enter 11111111, then click OK. 	
4		<ul style="list-style-type: none"> • Click EXPERT, then click IO PIN FUNCTION. 	
5		<ul style="list-style-type: none"> • Click the input or output to configure, then select the configuration from the drop-down menu. Refer to “IO Pin Function Configurations” on page 113 for a description of the configuration selections. • Click OK. 	

Appendix G, System Setup for Installing Software Updates

To prevent damage to the DispenseMotion software, the C drive of the DispenseMotion controller is factory-locked. It may be necessary to unlock the C drive to allow large updates to the DispenseMotion software to be fully installed. Follow this procedure to check the status of the C drive and to disable this feature if needed.

NOTE: You can request the latest DispenseMotion software at www.nordsonefd.com/DispenseMotion.

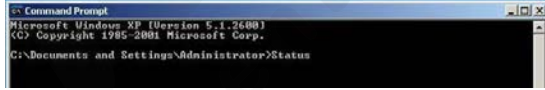
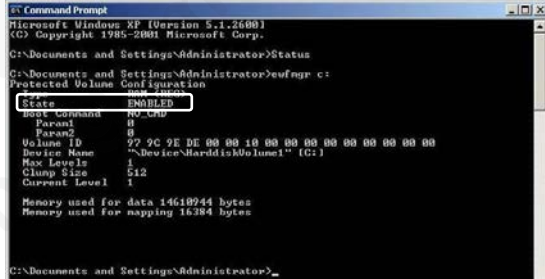
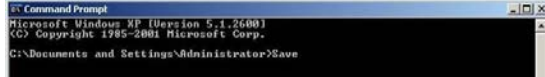
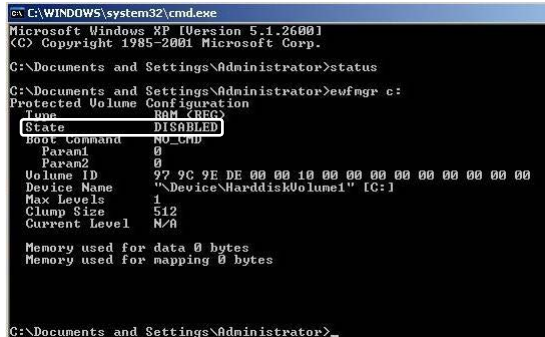
#	Step	Reference Image
1	<ul style="list-style-type: none"> Click Start > Programs > Accessories > Command Prompt. 	
2	<ul style="list-style-type: none"> At the command prompt, type STATUS and press the enter key. 	
3	<ul style="list-style-type: none"> Next to State, the system displays either ENABLED or DISABLED. If the State is DISABLED, then the DispenseMotion controller is configured correctly for updates. Skip to the end of this procedure. If the State is ENABLED, type DISABLE and press the enter key. 	
4	<ul style="list-style-type: none"> Type SAVE and press the enter key. 	
5	<ul style="list-style-type: none"> Click START > RESTART and allow the system to reboot for the change to take effect. After the DispenseMotion controller reboots, open the Command Prompt window again. 	
6	<ul style="list-style-type: none"> Type STATUS and press the enter key. <p>If the main drive is unlocked, the State shows DISABLED.</p> <p>You can now install DispenseMotion software updates or other needed software. To lock the main drive after installing software, open the Command Prompt window, type ENABLE > SAVE, and then reboot the system.</p>	

NORDSON EFD ONE YEAR LIMITED WARRANTY

Nordson EFD products are warranted for one year from date of purchase to be free from defects in material and workmanship (but not against damage caused by misuse, abrasion, corrosion, negligence, accident, faulty installation or by dispensing material incompatible with equipment) when the equipment is installed and operated in accordance with factory recommendations and instructions. Nordson EFD will repair or replace free of charge any part of the equipment thus found to be defective, on authorized return of the part prepaid to our factory during the warranty period. In no event shall any liability or obligation of Nordson EFD arising from this warranty exceed the purchase price of the equipment. This warranty is valid only when oil-free, clean, dry, filtered air is used.

Nordson EFD makes no warranty of merchantability or fitness for a particular purpose. In no event shall Nordson EFD be liable for incidental or consequential damages.

