

You have selected a reliable, high-quality dispensing system from Nordson EFD, the world leader in fluid dispensing. The 794-TC auger valve was designed specifically for industrial dispensing and will provide you with years of trouble-free, productive service.

This manual will help you maximize the usefulness of your 794-TC auger valve.

Please spend a few minutes to become familiar with the controls and features. Follow our recommended testing procedures. Review the helpful information we have included, which is based on more than 50 years of industrial dispensing experience.

Most questions you will have are answered in this manual. However, if you need assistance, please do not hesitate to contact EFD or your authorized EFD distributor. Detailed contact information is provided on the last page of this document.

The Nordson EFD Pledge

Thank You!

You have just purchased the world's finest precision dispensing equipment.

I want you to know that all of us at Nordson EFD value your business and will do everything in our power to make you a satisfied customer.

If at any time you are not fully satisfied with our equipment or the support provided by your Nordson EFD Product Application Specialist, please contact me personally at 800.556.3484 (US), 401.431.7000 (outside US), or Srini.Subramanian@nordsonefd.com.

I guarantee that we will resolve any problems to your satisfaction.

Thanks again for choosing Nordson EFD.

Srini Subramanian

Srini Subramanian, General Manager

Contents

| | |
|---|----|
| Contents | 3 |
| Introduction | 4 |
| Auger Assembly Sizes | 4 |
| How the 794-TC Valve Operates | 4 |
| How to Control the 794-TC Valve..... | 5 |
| Safety | 5 |
| Specifications..... | 6 |
| Operating Features..... | 7 |
| Installation | 8 |
| Unpack the System Components..... | 8 |
| Install the Valve..... | 9 |
| Set the Dispense Gap..... | 10 |
| Make System Adjustments..... | 11 |
| Changing Tips | 11 |
| Changing the Auger Assembly..... | 12 |
| Service..... | 12 |
| Purging | 12 |
| Cleaning the Fluid Cartridge Assembly | 13 |
| Part Numbers | 14 |
| Thermal Interface Materials..... | 14 |
| Accessories | 14 |
| Replacement Parts..... | 15 |
| Troubleshooting | 16 |
| Motor Voltage vs. Velocity..... | 19 |

Introduction

The 794-TC Series auger valve system is designed to make precise, repeatable deposits of TIM (thermal interface materials) or other highly abrasive pastes. Its robust tungsten carbide (TC) auger screw and fluid body liner resist wear from highly abrasive pastes to ensure long valve life. By combining screw-feed principles with precise time, pressure, and dispensing control, the 794-TC valve is able to provide accurate, repeatable deposits without damaging the metal particles of the solder.

The 794-TC valve is available in a variety of auger gap sizes. The auger gap size is selected based on the presence and size of particles in the dispensing material. The TC auger assembly can be easily replaced to change the gap size as needed.

794-TC Series auger valves are designed for use with ValveMate™ 7194 controllers and EFD's automated dispensing systems.



Auger Assembly Sizes

The following double-pitch auger assemblies are available:

- Standard (no gap) — for fluids without particles
- 0.05 mm (0.002") = 0.025 mm (0.001") around the auger — recommended for fluids with a particle size <math>< 20 \mu\text{m}</math>
- 0.10 mm (0.004") = 0.05 mm (0.002") around the auger — recommended for fluids with a particle size <math>< 40 \mu\text{m}</math>
- 0.15 mm (0.006") = 0.075 mm (0.003") around the auger — recommended for fluids with a particle size <math>< 40 \mu\text{m}</math>



A single-pitch, ultra-high flow auger assembly is also available:

- 0.15 mm (0.006") = 0.075 mm (0.003") around the auger — recommended for applications needing higher flow output for thermal interface materials (TIM)

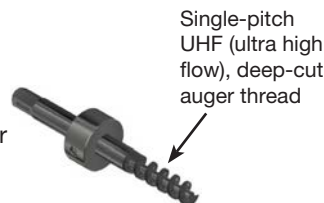

How the 794-TC Valve Operates

Input air pressure at up to 2.1 bar (30 psi) is applied to the material reservoir (1), forcing fluid into the path of the auger.

As the auger rotates, fluid moves along the auger flutes (2) and is forced out through the dispense orifice. The valve controller regulates the reservoir pressure, ensuring that there is enough pressure to keep the valve primed with fluid without forcing it past the auger. It is important to ensure that the reservoir fills continuously.

The duration of the dispensing time is controlled by adjusting the time control up or down until the required deposit size is established, at which point it is repeated with each initiate cycle.

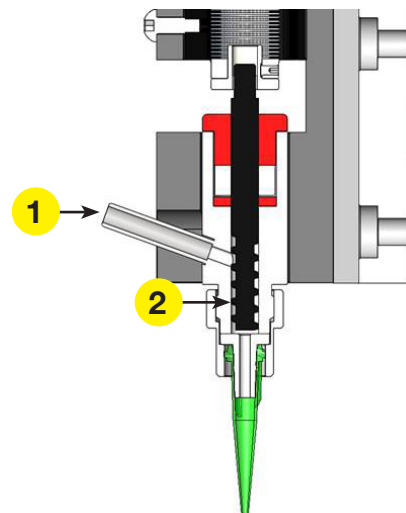

How to Control the 794-TC Valve

The ValveMate 7194 controller is recommended for use with the 794-TC auger valve. The ValveMate 7194 controller regulates solder feed pressure, dispense time, and auger speed. It provides motor startup acceleration limits and maximum current overload protection for extended motor life. The precision air pressure regulator ensures that consistent pressure is applied to the material in the syringe barrel.



Safety

It is intended that the 794-TC auger valve be rigidly mounted to and positioned by a suitable factory automation system and controlled by a suitable valve controller. Follow the procedures in this manual to select, install, and configure the automation system and valve controller.

Prohibited Uses

The 794-TC auger valve should not be operated in the following ways:

- Hand-held
- In damp or wet conditions
- In explosive atmospheres
- Under conditions which violate limits set in the specifications section
- Without all system guards, interlocks and other safety features in place and operational

WARNING

It is the responsibility of the factory automation system designer, builder and / or installer to include safety features sufficient to prevent personal injury or loss of life during operation.

Safety Precautions

The 794-TC auger valve should be installed, configured, and operated only by qualified personnel who have read and understood all appropriate sections of this manual as well as the operating instructions supplied with the factory automation system onto which it is installed. Protective eyewear should always be worn while operating, adjusting, and servicing the valve. Additional personal protective equipment should be used as appropriate for the material being dispensed. An SDS for all materials to be dispensed should be available at or near the operator's station. The factory automation system should be designed and installed so as to allow the operator to be positioned at a safe distance while operating and adjusting the valve.

Specifications

NOTE: Specifications and technical details are subject to engineering changes without prior notification.

| Item | Specification |
|---|--|
| Size | 61.0L x 32.0DIA mm (2.40L x 1.25DIA") NOTE: The valve length varies based on which side the fluid body / cartridge screw is installed; the measurement provided is the maximum length. |
| Weight | 470.0 g (16.6 oz) |
| Auger speed (dry) | 170–400 rpm based on voltage input |
| Auger pitch | High flow (double pitch), ultra high flow (single pitch) |
| Input voltage | 10–24 VDC (<10% ripple) |
| Maximum acceleration | 2.0 g (0.07 oz) |
| Maximum continuous current | 240 mA (time delay fuse recommended) |
| Maximum fluid pressure | 2.0 bar (30 psi) |
| Fluid inlet | 1/8" ID tubing supplied for connection |
| Mounting | 10-32, low profile |
| Luer lock tip adapter assembly | 303 stainless steel |
| Fluid inlet tube | 303 stainless steel |
| Fluid cartridge liner | Tungsten carbide |
| Auger | Tungsten carbide |
| Approvals | China RoHS |
| All stainless steel parts are passivated. | |

RoHS标准相关声明 (China RoHS Hazardous Material Declaration)

| 产品名称 Part Name | 有害物质及元素 Toxic or Hazardous Substances and Elements | | | | | |
|---|---|----------------------|----------------------|--|--|--|
| | 铅 Lead (Pb) | 汞 Mercury (Hg) | 镉 Cadmium (Cd) | 六价铬 Hexavalent Chromium (Cr6) | 多溴联苯 Polybrominated Biphenyls (PBB) | 多溴联苯醚 Polybrominated Diphenyl Ethers (PBDE) |
| 外部接口 External Electrical Connectors | X | 0 | 0 | 0 | 0 | 0 |
| <p>0: 表示该产品所含有的危险成分或有害物质含量依照EIP-A, EIP-B, EIP-C 的标准低于SJ/T11363-2006 限定要求。 Indicates that this toxic or hazardous substance contained in all the homogeneous materials for this part, according to EIP-A, EIP-B, EIP-C is below the limit requirement in SJ/T11363-2006.</p> <p>X: 表示该产品所含有的危险成分或有害物质含量依照EIP-A, EIP-B, EIP-C 的标准高于SJ/T11363-2006 限定要求。 Indicates that this toxic or hazardous substance contained in all the homogeneous materials for this part, according to EIP-A, EIP-B, EIP-C is above the limit requirement in SJ/T11363-2006.</p> | | | | | | |

Operating Features

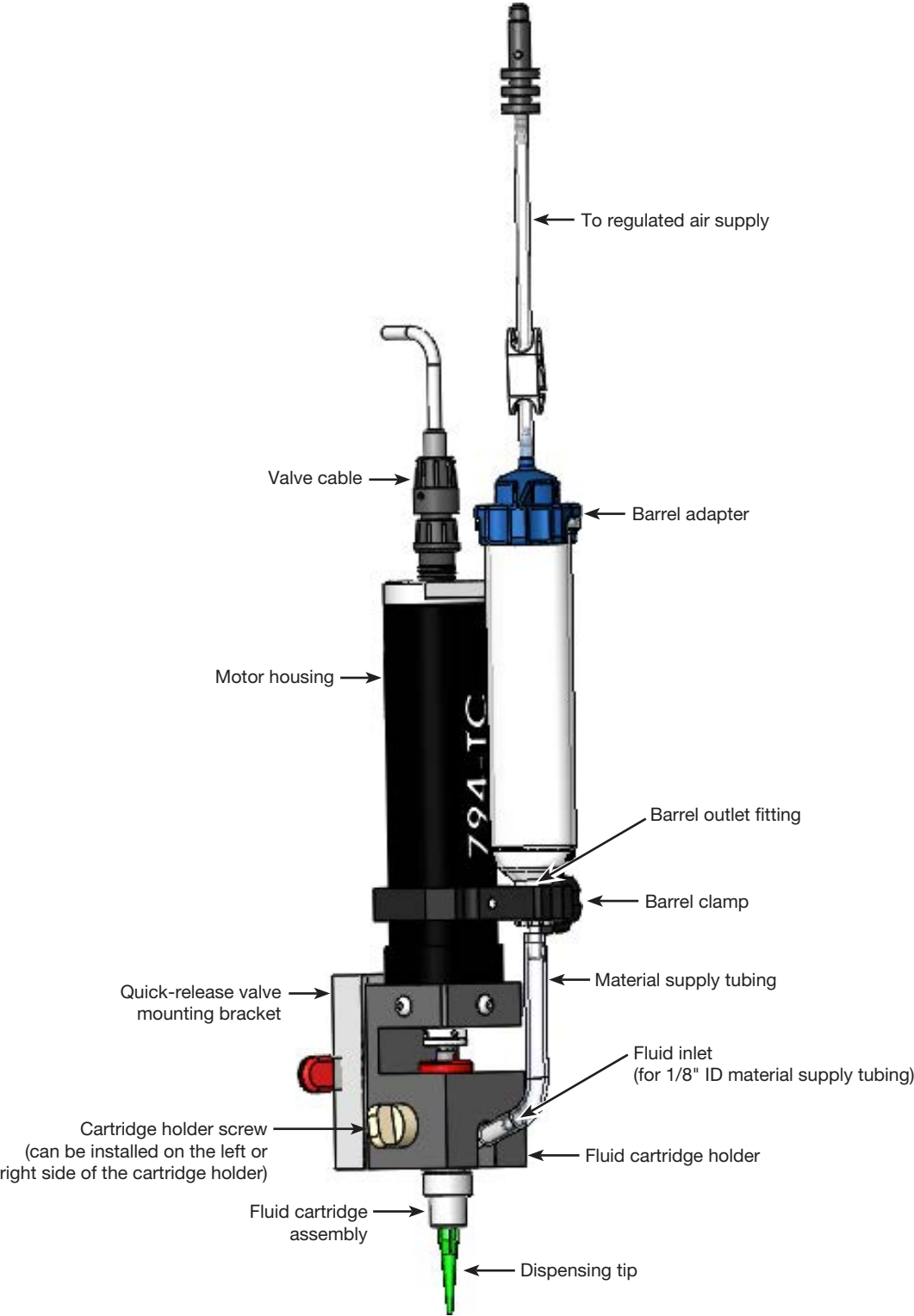

Installation

For complete installation, setup, and testing instructions, refer to the controller operating manual.

Unpack the System Components

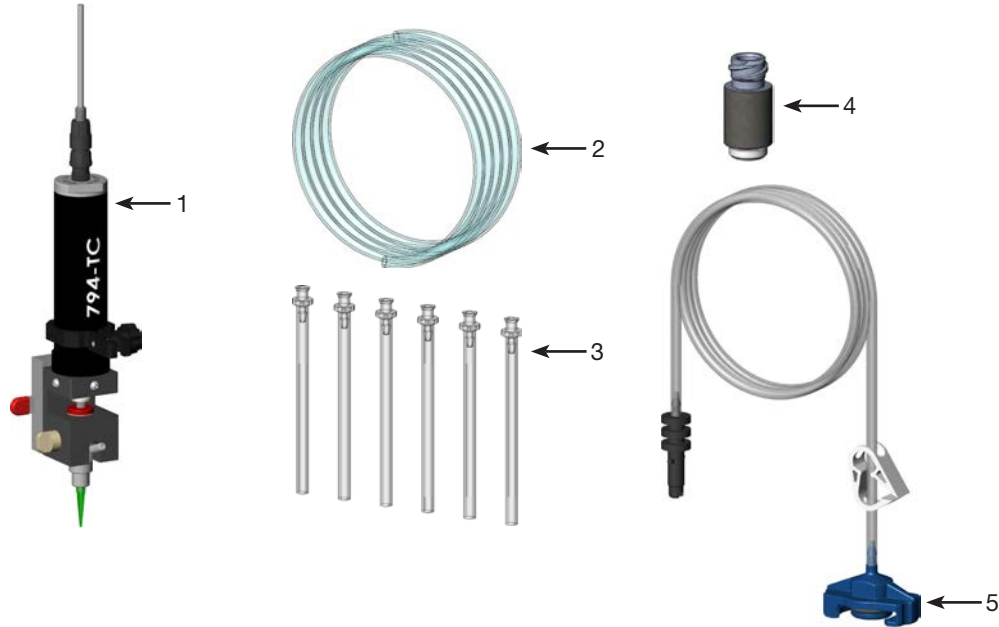

| Item | Description | Quantity |
|------|--|----------|
| 1 | 794-TC valve | 1 |
| 2 | Material supply tubing, 3/32" x 5/32" | 1 |
| 3 | Material supply tubing, 1/4" OD | 6 |
| 4 | 4 mm housing, push-in to luer (for optional use to connect the material supply tubing) | 1 |
| 5 | Adapter, 10 cc, 6 ft | 1 |
| | (Not shown) | |
| | Adapter, 30 cc, 6 ft | 1 |
| | Valve purge compound, 10 cc (8 g) | 1 |
| | 794-TC valve tip kit | 1 |
| | Valve purge SDS | 1 |
| | Valve purge instructions | 1 |
| | Dot test kit sheet | 3 |

Installation (continued)

Install the Valve

NOTE: Prior to installing the valve, read the associated reservoir and valve controller operating manuals to become familiar with the operation of all components of the dispensing system.

WARNING

Disconnect the electrical power and inlet air pressure to the factory automation system and valve controller prior to proceeding.

1. Mount the valve securely to the Z axis of the robot using the bracket provided for the valve or another appropriate mounting bracket for other machines.
2. Connect the motor lead wire to the valve controller. The white wire connects to the (+) terminal and the black wire to the (-) terminal.
3. Attach the barrel outlet fitting to the end of a barrel of material to be dispensed.
4. Insert the barrel into the barrel clamp, position as required, and clamp securely.
5. Use the supplied 4 mm push-in fitting and 3/32" x 5/32" material supply tubing to connect the material supply to the fluid inlet on the auger valve.

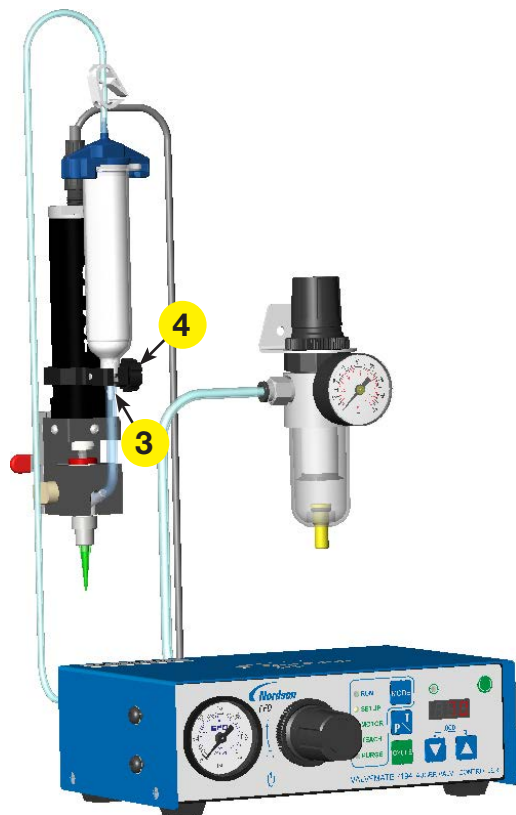

6. Attach the blue end of the barrel adapter assembly to the end of the barrel.
7. Connect the bayonet fitting to the valve controller air output.
8. Securely install a tip onto the luer fitting.

NOTE: Tip selection is critical to achieve optimum valve performance. In general, use the shortest and least restrictive tip possible to provide the best paste flow. 794-TC valves are packaged with a dispensing tip kit for maximum fluid control.

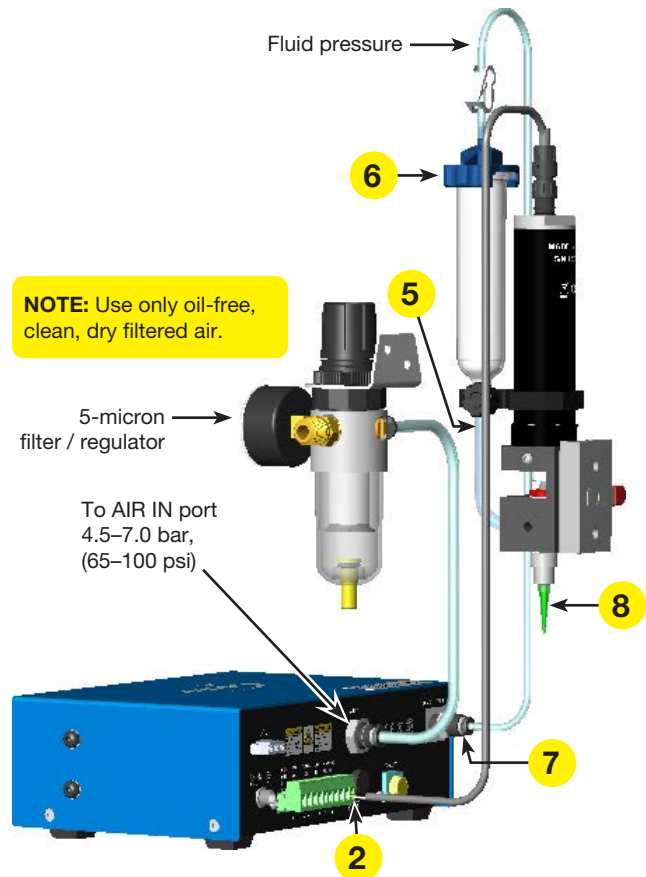

White wire: 10–24 VDC MOTOR+
Black wire: 10–24 VDC MOTOR-

Installation (continued)

Set the Dispense Gap

The dispense gap is the distance between the workpiece and the tip. This gap is tip- and fluid-dependent. The tip must lower close enough to the workpiece such that dispensed fluid touches the workpiece and stays on the workpiece after the tip raises to move to the next deposit location. This gap can also affect deposit size and shape.

NOTE: In the robot operating manual, this gap is called the tip-to-workpiece offset, or Z clearance. Refer to the robot manual for all information related to the automated dispensing system.

1. Ensure that a tip is securely installed on the luer fitting.
2. Operate the robot to position the tip over the workpiece with an initial gap setting as follows:
 - If a non-chamfered tip is being used, set the initial gap to approximately 25% of the outside tip diameter.
 - For chamfered tips, set the initial gap to 25% of the inside diameter.
3. Dispense the desired pattern and observe the result.
4. Use the following guidelines to set the correct dispense gap for your application:
 - If the deposit does not separate from the valve, lower the tip for a smaller gap.
 - If the tip drags through the dispensed deposit, raise the tip for a larger gap.
5. Adjust valve speed or fluid pressure as needed to achieve the desired dispense result at the selected dispense gap setting.



Installation (continued)

Make System Adjustments

Dispense time is the primary method of making small adjustments in deposit size. In general, larger deposits require longer dispense times, larger diameter tips and larger dispense gaps. Be sure to allow settling time (before dispense) and dwell time (after dispense). Very small deposits may require chamfered tips.

To ensure that the fluid cartridge fills continuously, adjust the fluid pressure to a setting that is just below where drooling occurs without the auger turning.



Changing Tips

Follow these steps to change the tip. Refer to the EFD Precision Dispense Tip Sheet for available gauge sizes and dimensions.

CAUTION

Before any component change or service activity, relieve air pressure from the fluid reservoirs.

1. Depressurize the system.
2. Unscrew the tip from the luer fitting.
3. Slide the replacement tip over the luer fitting and hand-tighten to secure it.
4. Check the dispense gap and adjust the dispense program as needed. Refer to “Set the Dispense Gap” on page 10 of this manual and to the robot operating manual.

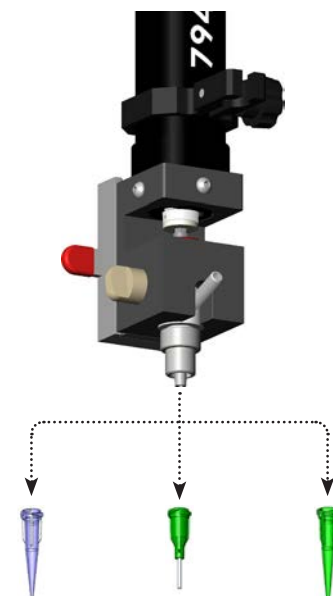

Changing the Auger Assembly

Follow these steps to change the auger gap by replacing the fluid cartridge assembly. The auger screw is housed in the fluid cartridge assembly.

1. Remove the tip. Refer to “Changing Tips” on page 11 as needed.
2. Loosen the cartridge holder screw.
3. Pull down and remove the fluid cartridge assembly.
4. Install the replacement fluid cartridge assembly and then hand-tighten the holder screw.
5. Reinstall the tip.
6. Check the dispense gap and adjust the dispense program as needed. Refer to “Set the Dispense Gap” on page 10 of this manual and to the robot operating manual.

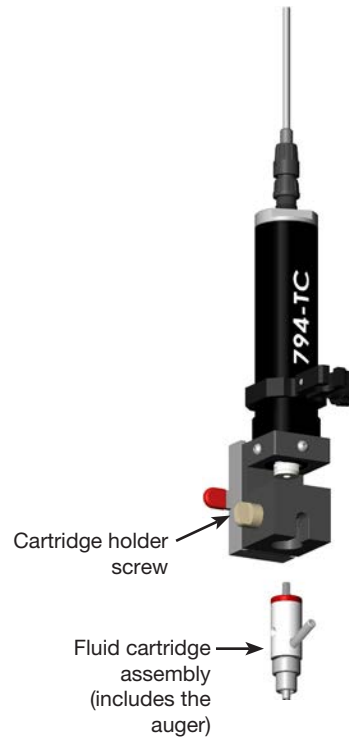

Service

⚠ CAUTION

Prior to servicing the valve, read and understand the operating instructions for all components of the dispensing system, especially this manual. Perform a complete service shutdown of the automated dispensing system before proceeding.

Purging

The use of valve purge compound (P/N 7019147) between production shifts or after every eight hours of run time is highly recommended. The compound cleans any material residue from the fluid path and conditions the valve for future use.

1. Install the barrel of valve purge compound on the fluid inlet.
2. Apply reservoir pressure and cycle the valve until the valve purge compound has pushed all residual material from the valve. Leave the compound in the valve until future use.
3. To remove the valve purge compound, install the material to be dispensed and cycle the valve until all compound has been pushed from the valve.

Service (continued)

Cleaning the Fluid Cartridge Assembly

If the purging procedure detailed above is not sufficient to clean the valve, follow these steps to disassemble and clean the fluid cartridge assembly, which includes the auger.

To disassemble and clean the fluid cartridge assembly components:

1. Remove the tip.
2. Loosen the cartridge holder screw.
3. Pull down and remove the fluid cartridge assembly.
4. Disassemble the luer taper and luer lock retaining nut.
5. Remove the cap nut from the auger.
 - NOTE:** Do not remove the collar from the auger.
6. Remove the seal and auger screw from the fluid cartridge.

To clean the components and then reassemble:

1. Clean all parts using any suitable solvent and brushes or an ultrasonic cleaning device.
2. Inspect the seal for signs of wear or damage and replace if needed.
3. Insert the seal in the fluid cartridge.
4. Apply grease to the top of the seal.
5. Insert the auger, being careful not to damage the seal.
6. Reinstall the cap nut.
7. Reassemble the luer taper and luer lock retaining nut onto the fluid cartridge.
8. Reinstall the fluid cartridge assembly and then hand-tighten the holder screw.
9. Reinstall the tip.

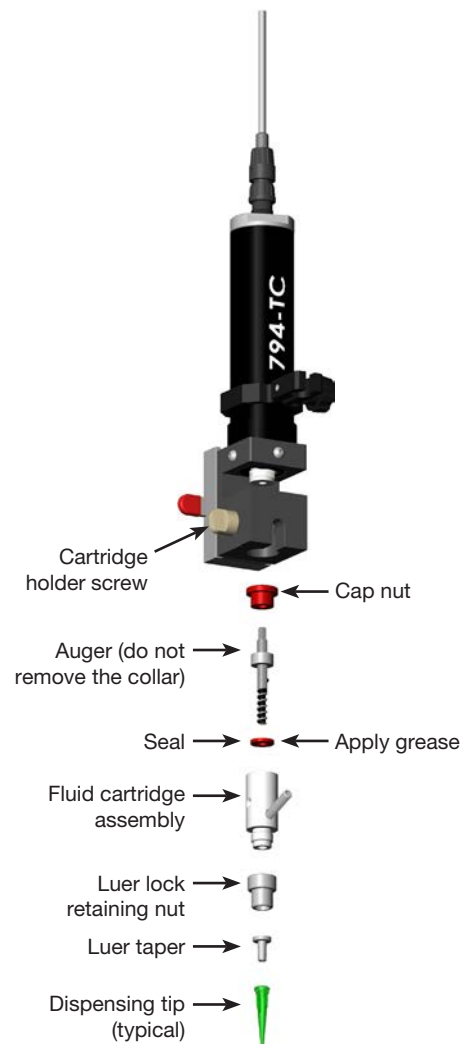

Part Numbers





| Part # | Description |
|---------|---|
| 7363510 | 794-TC valve, high flow (double pitch), brush, standard (no gap) — recommended for fluids without particles |
| 7363511 | 794-TC valve, high flow (double pitch), brush motor, 0.05 mm (0.002") gap — recommended for particle size <20 µm |
| 7363512 | 794-TC valve, high flow (double pitch), brush motor, 0.10 mm (0.004") gap — recommended for fluids with large particles <40 µm |
| 7364566 | 794-TC valve, high flow (double pitch), brush motor, 0.15 mm (0.006") gap — recommended for fluids with large particles <40 µm |
| 7364621 | 794-TC valve, ultra high flow (single pitch), brush motor, 0.15 mm (0.006") gap — recommended for applications needing higher flow output for thermal interface materials (TIM) |

Thermal Interface Materials



Nordson EFD synthetic-based, silicone-free thermal interface materials provide an ideal thermal solution by ensuring reliable heat transfer over a longer time than most industrial thermal interface materials. Visit www.nordsonefd.com/ThermalCompound for details or to request a free sample.

Accessories

| Item | Part # | Description |
|---|---------|---|
|  | 7363518 | Robot mounting bracket for 794-TC valve |
|  | 7014840 | 1/4" hose to barrel adapter |

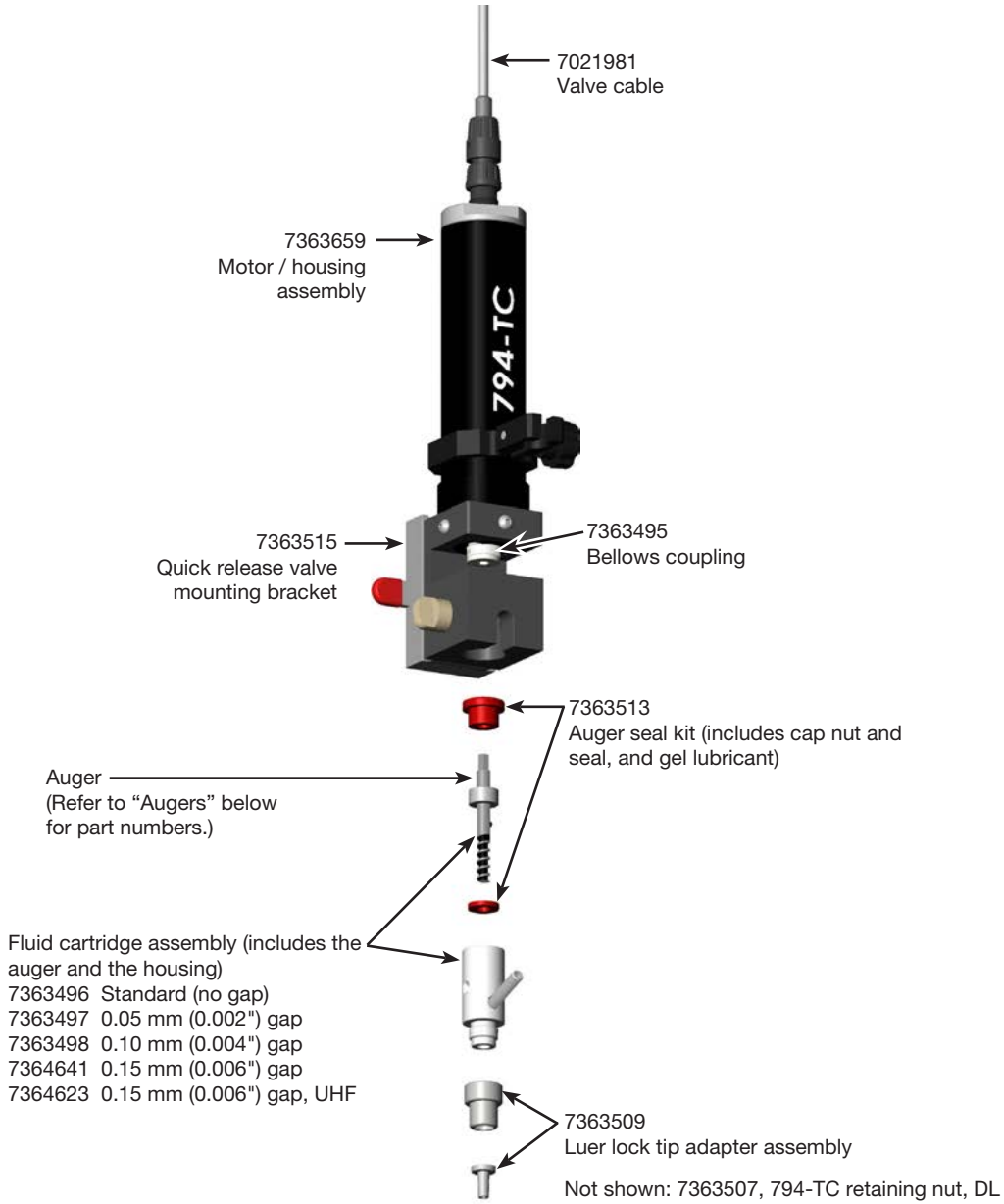
Replacement Parts



| Augers | Part # | Description |
|---|---------|--|
|  <p>Double-pitch auger thread</p> | 7363503 | Standard, high flow (double pitch), no gap |
| | 7363504 | Standard, high flow (double pitch), 0.05 mm (0.002") gap |
| | 7363505 | Standard, high flow (double pitch), 0.10 mm (0.004") gap |
| | 7364527 | Standard, high flow (double pitch), 0.15 mm (0.006") gap |
|  <p>Single-pitch, deep- cut auger thread</p> | 7364622 | Standard, ultra high flow (single pitch), 0.15 mm (0.006") gap |

Troubleshooting

| Problem | Possible Cause | Corrective Action |
|-------------------|---|---|
| Auger not turning | Wiring fault | Check accuracy and tightness of all connections. |
| | Cable damaged | Check the cable for damage; replace if necessary. |
| | Controller fault | Check the controller output with a voltmeter. Refer to the controller manual for additional information. |
| | Controller set incorrectly | Check the settings of the controller: motor voltage, direction, dispense duration. Refer to the controller manual for additional information. |
| | Motor failed or damaged | Replace the pre-wired motor assembly. Contact your Nordson EFD representative for assistance. |
| | Auger jammed | Clean the auger assembly. If the auger continues to jam, change to an auger with a larger gap. |
| | Coupling loose | Tighten the set screws. |
| No deposit | Motor turning in wrong direction (when viewed from above, the motor should be turning clockwise; if the motor is turning counterclockwise, then the motor direction is incorrect) | Check the controller motor direction settings. Refer to the controller manual for correct connections. Reverse the motor wires. |
| | Depleted barrel | Replace with a filled barrel. |
| | No air pressure | Check the controller input air and air settings. |
| | Material cured or dried | Replace with fresh material. |
| | Insufficient air pressure | Increase pressure. |
| | Delivery path clogged | Run one or more purge routines. |
| | | Clean the delivery path. |
| | | Replace the tip, supply hose, and / or fittings. |
| Smear deposits | Dispense gap too small | Decrease the amount of fluid being dispensed or increase the dispense gap. |
| | Valve loose | Tighten the mounting connections. |
| | Automated dispensing system fault | Service the automated dispensing system. Contact your Nordson EFD representative for assistance. |
| | Automated dispensing system hunting for position | Tune the automated dispensing system. Contact your Nordson EFD representative for assistance. |

Continued on next page

Troubleshooting (continued)

| Problem | Possible Cause | Corrective Action |
|-------------------------------|-------------------------------------|--|
| Skipped deposits | Material build-up on outside of tip | Add a tip wiping routine to the program. |
| | | Switch to a chamfered tip. |
| | Tip too small | Change to a larger (smaller number) tip. |
| | Dispense gap too small or too large | Decrease the dispense gap if the deposit is building up on the tip. Increase the gap if there is no visible deposit (if the tip is too close to the workpiece, fluid cannot exit the tip.) Refer to "Set the Dispense Gap" on page 10. |
| | Inconsistent material | Check and / or mix material. |
| | Air in material | Run one or more purge routines. |
| | | De-air the material (vacuum or centrifuge). |
| Damaged tip | Replace the tip. | |
| Inconsistent deposits | Poor material cut-off | Reverse the motor briefly at the end of the deposit routine. |
| | | Switch to a chamfered tip. |
| | Tip too large | Change to a smaller (larger number) tip. |
| | Dispense gap too small or too large | Decrease the dispense gap if the deposit is building up on the tip. Increase the gap if there is no visible deposit (if the tip is too close to the workpiece, fluid cannot exit the tip.) Refer to "Set the Dispense Gap" on page 10. |
| | Inconsistent material | Replace and / or mix material. |
| | Air in material | Run one or more purge routines until cleared. |
| | | De-air the material (vacuum or centrifuge). |
| | Premature retraction | Increase the dwell time. |
| | Process temperature changing | Install a temperature control system, such as an EFD ProcessMate® 6500. |
| Damaged tip | Replace the tip. | |
| <i>Continued on next page</i> | | |

Troubleshooting (continued)

| Problem | Possible Cause | Corrective Action |
|---|---|---|
| Leaking at fittings | Material pressure too high | Decrease the pressure to 2 bar (30 psi) or lower. |
| | Fittings loose | Tighten fittings. |
| | Tubing loose on fittings | Replace the tubing. |
| | Fitting(s) cracked | Replace the barbed fitting(s). |
| | Material incompatibility | Replace the fitting(s) with stainless steel fittings. |
| Leaking at auger | Worn or damaged auger seal | Replace the auger seal. |
| Material being damaged | Broken auger | Replace the auger. |
| | Worn auger bearing | Replace the auger bearing. |
| | Auger gap too small (if the auger gap is too small, particles can be crushed) | Replace the auger with an auger that has a larger gap size. |
| Residual material at material change-over | Dead spots in material path at barbs | Replace the fitting(s) with stainless steel fittings. |

Motor Voltage vs. Velocity

This graph shows the motor rotation speed at 10–24 VDC input from the ValveMate 7194 controller.

794-TC Auger Valve Motor (Brush-Type) Voltage vs. Velocity, No-Load Condition

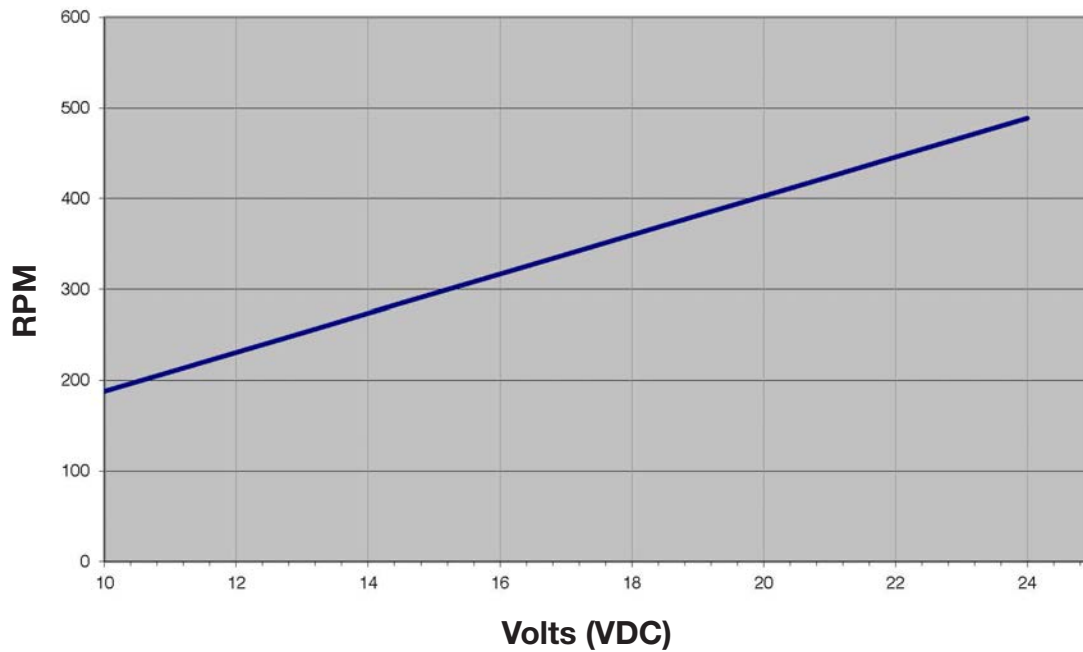

NORDSON EFD ONE YEAR LIMITED WARRANTY

This Nordson EFD product is warranted for one year from the date of purchase to be free from defects in material and workmanship (but not against damage caused by misuse, abrasion, corrosion, negligence, accident, faulty installation, or by dispensing material incompatible with equipment) when the equipment is installed and operated in accordance with factory recommendations and instructions.

Nordson EFD will repair or replace free of charge any defective part upon authorized return of the part prepaid to our factory during the warranty period. The only exceptions are those parts which normally wear and must be replaced routinely, such as, but not limited to, valve diaphragms, seals, valve heads, needles, and nozzles.

In no event shall any liability or obligation of Nordson EFD arising from this warranty exceed the purchase price of the equipment.

Before operation, the user shall determine the suitability of this product for its intended use, and the user assumes all risk and liability whatsoever in connection therewith. Nordson EFD makes no warranty of merchantability or fitness for a particular purpose. In no event shall Nordson EFD be liable for incidental or consequential damages.

This warranty is valid only when oil-free, clean, dry, filtered air is used, where applicable.



For Nordson EFD sales and service in over 40 countries, contact Nordson EFD or go to www.nordsonefd.com.

Global

800-556-3484; +1-401-431-7000
info@nordsonefd.com

Europe

00800 7001 7001
infoefd.europe@nordsonefd.com

Asia

China: +86 (21) 3866 9006; china@nordsonefd.com
India: +91 80 4021 3600; india@nordsonefd.com
Japan: +81 03 5762 2760; japan@nordsonefd.com
Korea: +82-31-736-8321; korea@nordsonefd.com
SEAsia: +65 6796 9522; sin-mal@nordsonefd.com

The Wave Design is a trademark of Nordson Corporation.
©2020 Nordson Corporation 7363721 v041620