

# 752HF Series Dispense Valve

## Installation Guide

### Introduction

The 752HF Series fluid dispense valves are simple to use and will operate many millions of cycles without maintenance. The 752 Series are compact, precise, adjustable diaphragm valves for dispensing low to medium viscosity fluids.

All 752HF Series valves use the same actuating assembly. But fluid body materials differ according to the model. The 752HF Series fluid bodies are constructed with the outlet at the end of the fluid body. Fluid body materials are:

- 752HF-SS – 303 stainless steel
- 752HF-A – Acetal copolymer

Each valve is shipped with a dispensing tip adapter, fluid inlet fitting, and 5-foot actuating air hose installed.

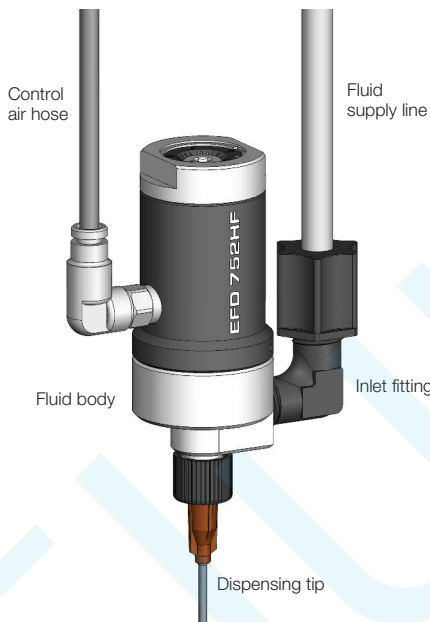
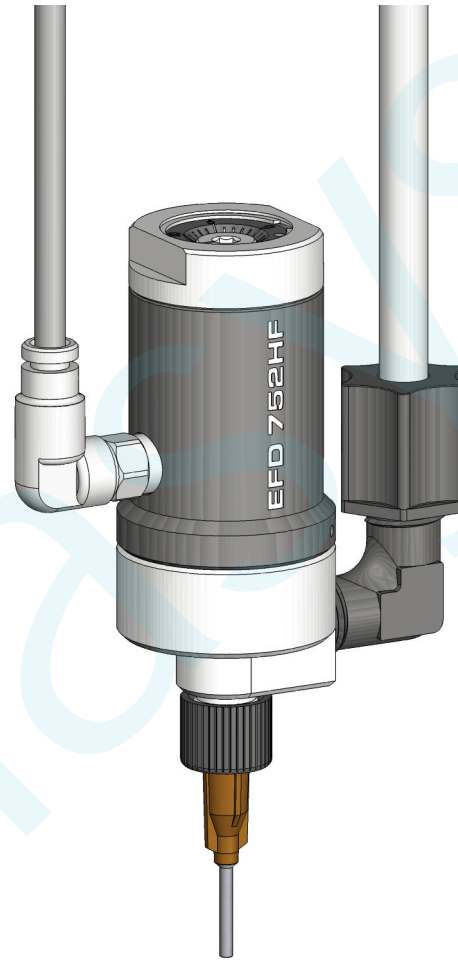

Electronic pdf files of Nordson EFD manuals are also available at [www.nordsonefd.com](http://www.nordsonefd.com)

# Installation

**Important Note:** Set desired deposit size by adjusting valve open time. Refer to valve controller operating manual.

Prior to installing this valve, please read the associated reservoir and valve controller operating instructions to become familiar with the operation of all components of the dispensing system.

1. Connect fluid supply line to valve. If 3/8" OD tubing is used, change to fitting #7007038 supplied.
2. Connect the fluid supply line to reservoir. The reservoir can accept either 1/4" OD or 3/8" OD tubing using #7020159 supplied.
3. Connect valve control air hose to ValveMate™ 8000 (solenoid pack) used to control valve open time.
4. Press tip onto luer slip of fluid body. Install tip retaining nut. Finger-tighten only. Do not over-tighten as this may cause damage / cracking of tip hub.

5. Fill reservoir by pouring fluid directly into tank liner or manufacturer's bottle placed inside reservoir. Secure cover prior to setting pressure.
6. Set reservoir pressure to low for thin fluids and higher for thick fluids.
7. Set the diaphragm stroke starting with no more than 1/2 turn open.\*
8. Place a cup under the dispensing tip and actuate the valve until fluid lines, valve and dispensing tip are free of air.
9. Set desired flow rate by adjusting fluid reservoir pressure or changing dispensing tip.

\* Do not overtighten the stroke adjustment knob or open it more than two full turns. If open more than two turns, pressurized liquid could force open the diaphragm seal, resulting in continuous liquid flow.

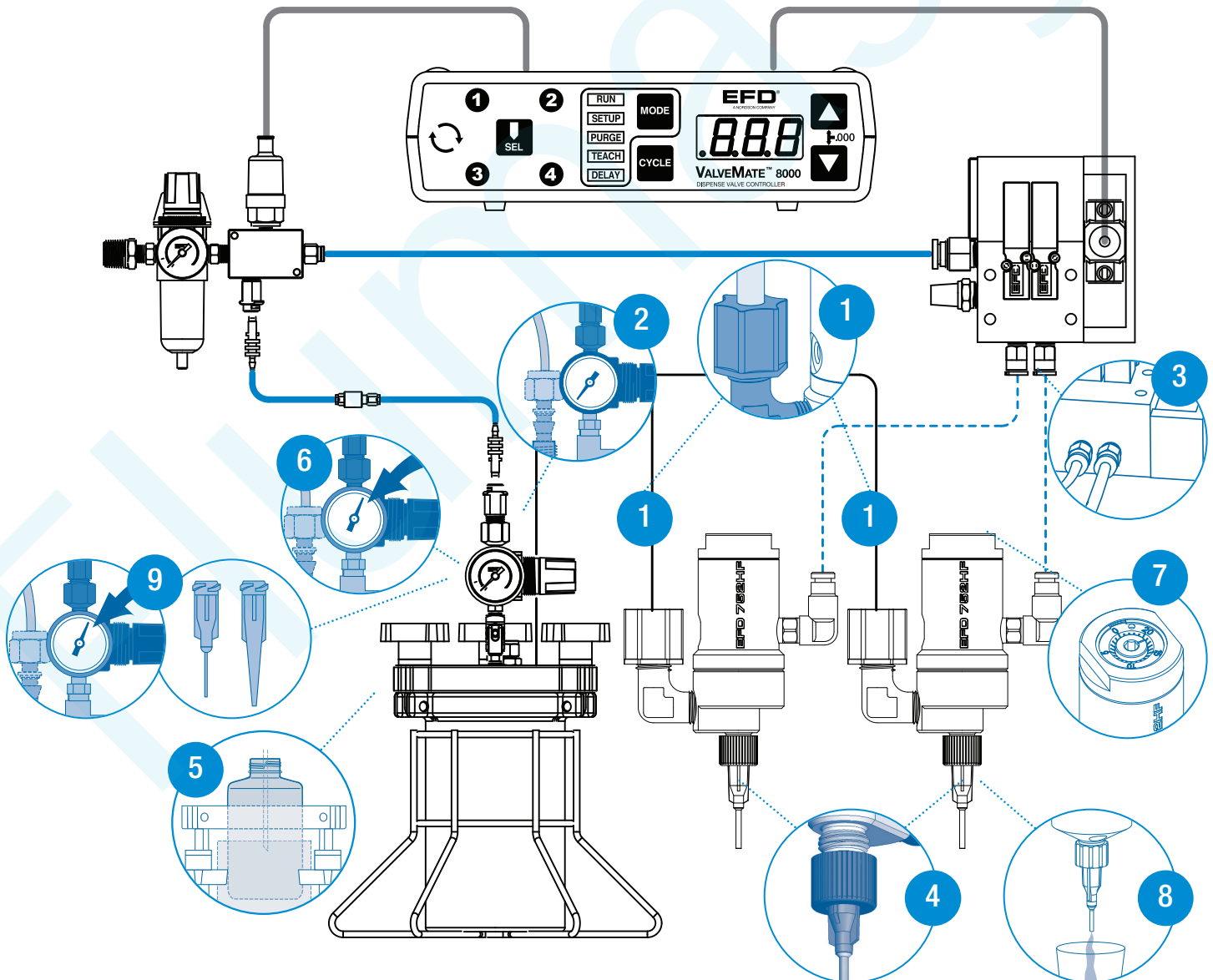

# How the Valve Operates

The primary control of deposit size is the valve open time.

Input air pressure at 70 psi (4.8 bar) forces the internal piston ① to move. ② The piston rod pulls open the diaphragm seal, ③ permitting fluid flow. When the input air pressure is relieved, the spring retracts the piston and the diaphragm closes.

The amount of fluid dispensed will depend on the time the valve is open, the viscosity of the fluid, the air pressure in the fluid reservoir, the dispensing tip size and the diaphragm stroke.

Flow rate is a function of reservoir pressure, tip size, and fluid viscosity.

## To calibrate the valve:

- Insert 3 mm allen wrench into stroke control port.
- Turn inner knob clockwise until full stop against internal actuator piston.
- Insert 1.5 mm allen wrench into stroke control ring hole.
- Apply slight pressure and rotate until "0" aligns with stroke control port hash mark.
- Stroke control is now calibrated. Insert 3 mm allen wrench into stroke control port and turn counter-clockwise to set stroke flow control.

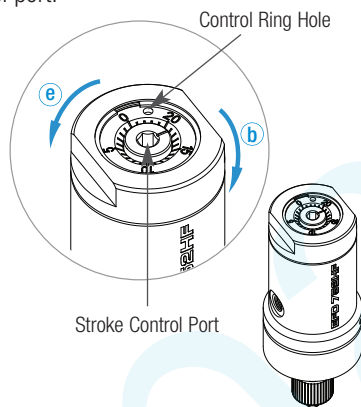

## 752HF-SS and 752HF-A Fluid Flow

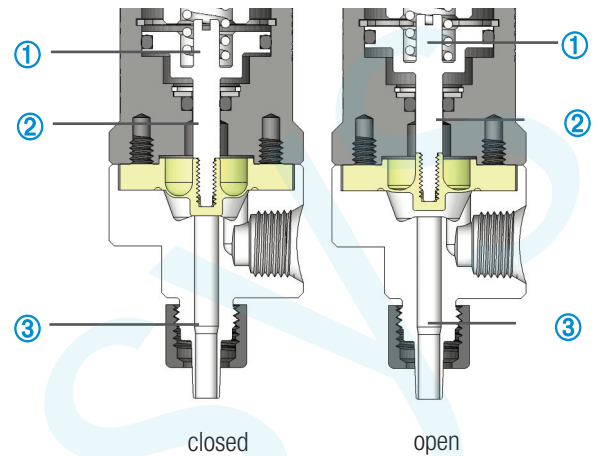

# ValveMate Concept

**Important Note:** Order your 1, 2, 3, or 4 solenoid manifold block assembly separately. Consult EFD for recommendations.

The ValveMate 8000 provides easy adjustment of valve output for maximum end-user convenience and efficiency. Valve open time is the primary control of deposit. The 8000 puts push-button adjustment of valve open time where it needs to be — at the valve.

The ValveMate 8000 features micro-processor circuitry for extremely precise control of deposit size. Feed lines can be purged, initial deposit sizes set, and adjustments made quickly and easily at the dispensing station, without stopping the production line.

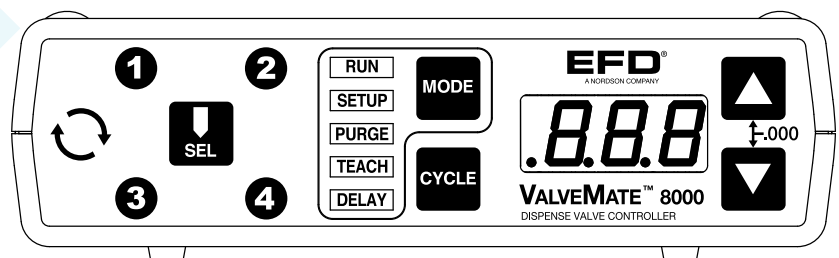

**Note:** Nordson EFD automated dispensing systems have integrated ValveMate controllers for operating all EFD dispense valves.

[www.nordsonefd.com](http://www.nordsonefd.com) [info@nordsonefd.com](mailto:info@nordsonefd.com) USA & Canada 800.556.3484 Europe +44 (0) 1582 666334 Asia +86 (21) 3866 9006

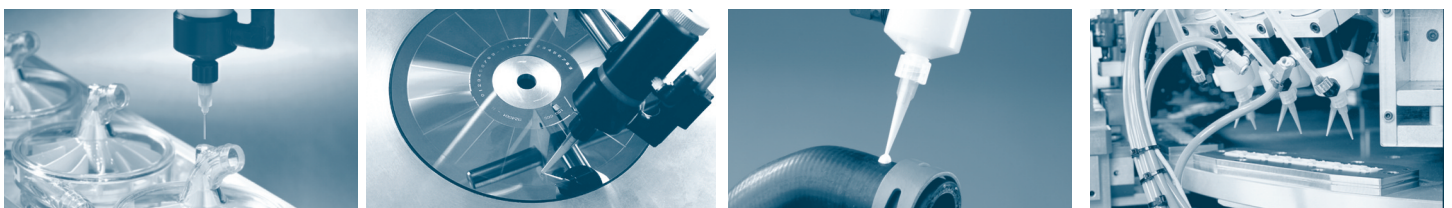

# Specifications

## General

**Diaphragm:** UHMW\* polyethylene

**Air pressure required:** 70 to 90 psi (4.8 to 6.2 bar)

**Maximum fluid pressure:** 70 psi (4.8 bar)

**Maximum operating temperature:** 43°C (110°F)

**Mounting:** M5 x 0.8

## 752HF-SS and 752HF-A

**Size:** 77.3 mm length x 28.6 mm diameter  
(3.04" x 1.13")

**Weight:** 752HF-SS – 123 grams (4.30 ounces)  
752HF-A – 81 grams (2.85 ounces)

**Air cylinder body:** 752HF-SS – Hard-coated aluminum  
752HF-A – Hard-coated aluminum

**Fluid body:** 752HF-SS – 303 stainless steel  
752HF-A – Acetal copolymer

**Free flow orifice:** 3.18 mm (.125")

**Fluid inlet thread:** 1/8-27 NPT

**Tip retaining nut:** Standard for EFD dispense tips

\* Ultra High Molecular Weight

For consistent dispense valve operation and easy adjustment of valve output, Nordson EFD recommends using the ValveMate 8000 controller on all automatic, semi-automatic and benchtop applications.

Nordson EFD dispensing robots incorporate dispensing control into the main system.

Contact the EFD Dispense Valve Systems Group for details.

