

741MD-SS Needle Valve

Maintenance & Parts Guide

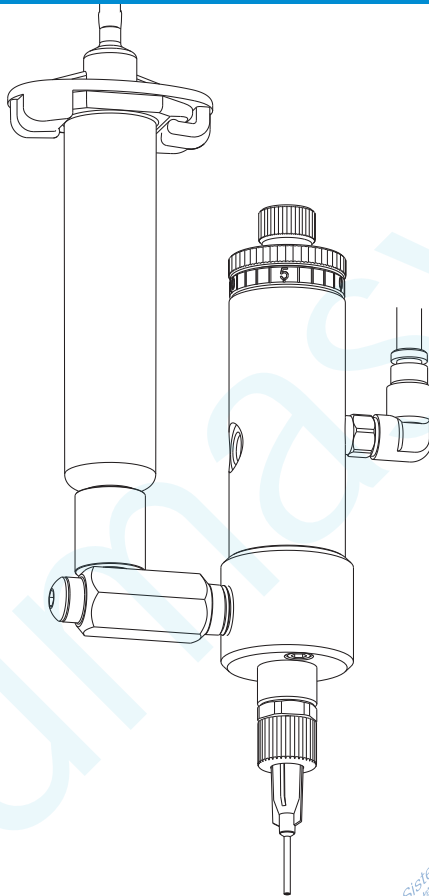

IMPORTANT!

Save this Sheet.

Forward to
Maintenance or
Tool Crib Supervisors

Electronic pdf files of EFD
manuals are also available at
www.nordsonefd.com

Valve Disassembly and Reassembly Procedures

CAUTION: To prevent damage, the valve must be disassembled starting at the fluid outlet end of the valve.

Valve maintenance

To thoroughly clean the fluid body and replace needle packings:

1. Remove inlet fitting and tip adapter.
2. Remove fluid body from air cylinder body, then remove O-ring.
3. Use tool #7021552 to remove needle packings from fluid body.
4. Remove any remaining packings and spring from needle.
5. Clean needle with cloth dampened in solvent and lubricate with Nye Lubricant #865 gel included in the General Maintenance Kit. Lubricate and reinstall the needle packing assembly.
6. Install new, lubricated O-ring on fluid body. Then install chamber into air cylinder body.
7. Turn the fluid body to position fluid inlet hole in the desired location. Install and tighten body mounting screws (2). Torque to 14 inch pounds (1.58 Nm).
8. Reinstall tip adapter/seat assembly.

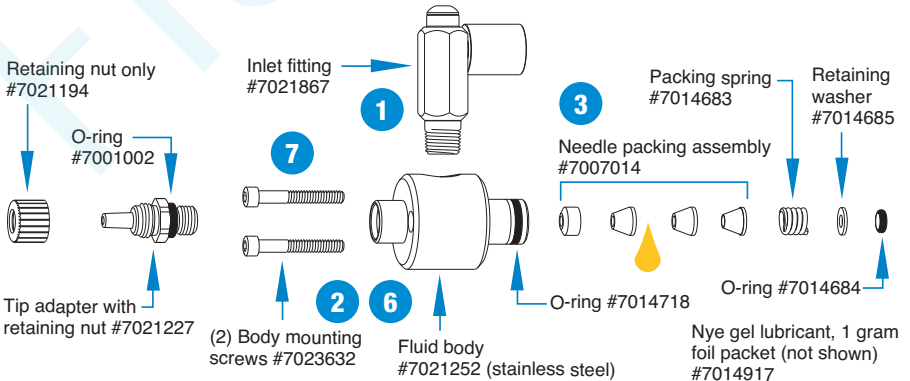

Replacing piston and needle assembly or piston O-ring

9. Remove needle stroke control knob.
10. Remove piston return spring and thrust washers.
11. Remove the snap ring.
12. With small pliers on the spring pilot, pull the piston and needle assembly out of the air cylinder body. The piston and needle assembly is one unit and cannot be disassembled.
13. Clean air cylinder body wall and replace piston O-ring. Lubricate with Nye Lubricant #865 gel included in the General Maintenance Kit.
14. Reassemble the valve in reverse order of disassembly.

Note: Ensure that the lower cylinder needle O-ring is back in place before reinstalling the packing spring.

General Maintenance Kit #7007030

Includes all O-rings, needle packing set and foil pack of Nye Lubricant #865 gel.

Maintenance Tools:

6" adjustable wrench
snap-ring pliers
packing extraction tool #7021552

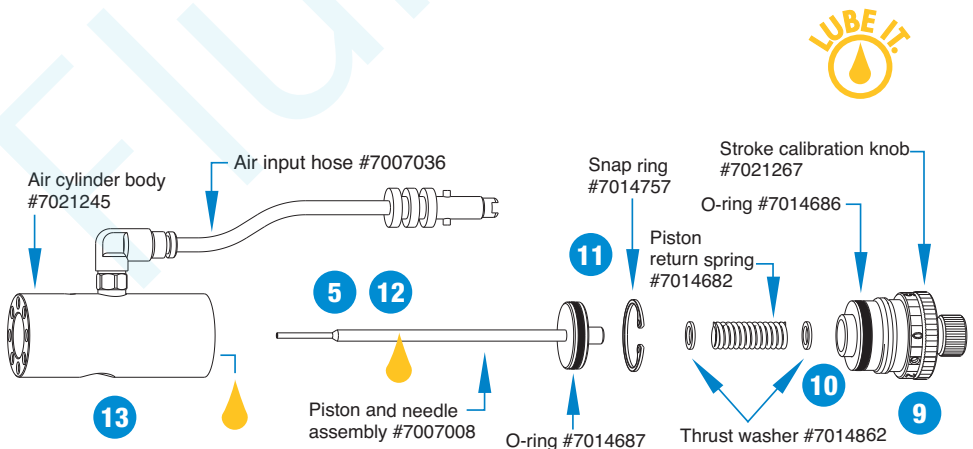

Troubleshooting Guide

No fluid flow

- If valve operating air pressure is too low, the valve will not open. Increase air pressure to 70 psi (4.8 bar) minimum.
- The reservoir air pressure may not be high enough. Increase pressure.
- The needle stroke adjustment may be closed. Open stroke adjustment.
- Material may have clogged the fluid body or output tip adapter. Clean the valve.
- Dispensing tip retaining nut may not have been tightened enough to unseat the needle. Tighten the nut.

Steady drip

- Remove the tip adapter/seat assembly. Clean and inspect the needle. Replace dispensing tip.
- Make sure tip size is not larger than 22 gauge.

Fluid leaks out the drain hole

- Fluid leaking out the drain hole on the side of the valve indicates the needle packings are worn. Replace needle packings.

Inconsistent deposits

- Inconsistent deposits can result if the air pressure controlling the valve and/or supplying the reservoir is fluctuating or if the valve operating pressure is less than 70 psi (4.8 bar). Check to be sure air pressures are constant and the valve operating pressure is 70 psi (4.8 bar).
- The time the valve is open must be constant. Check to be sure the valve controller is providing a consistent output.

Calibration Feature

The stroke control reference ring of each 741MD-SS valve is factory calibrated to zero position. Slight internal variations in dispensing tips may require the stroke control to be recalibrated when tips are changed.

To do so:

1. Make a note of the current stroke setting number.
2. Turn the calibration knob (inner) counterclockwise one full turn.

3. Install the new dispensing tip and ensure that the retaining nut is tightened fully.
4. Turn the stroke adjustment knob (outer) clockwise until it stops at the zero position.
5. Turn the calibration knob clockwise until it stops. The stroke adjustment is now calibrated to zero.
6. Reset stroke to the required position noted in step 1.

In the event that the stroke reference ring must be repositioned or reset to the zero mark, use the following procedure:

- A. Remove the dispensing tip, if installed.
- B. Turn the small knob counterclockwise one full turn.
- C. Turn the large knob clockwise until it stops.

If the zero on the reference ring does not line-up with the index mark, continue with the following steps:

- D. Loosen the small set-screw located on the reference ring.
- E. Rotate reference ring until it aligns with the reference line on the air cylinder body.
- F. Tighten the small set-screw to lock the reference ring into position.
- G. Install a dispensing tip and follow calibration procedure steps 3 to 5.

