

ABB GENERAL PURPOSE DRIVES

ACS480 drives

Hardware manual



ACS480 drives

Hardware manual

Table of contents



1. Safety instructions



4. Mechanical installation



6. Electrical installation – IEC



7. Electrical installation – North America



3AXD50000047392 Rev F
EN

Original instructions
EFFECTIVE: 2024-05-20

Table of contents

1 Safety instructions

Contents of this chapter	15
Use of warnings and notes	15
General safety in installation, start-up and maintenance	16
Electrical safety in installation, start-up and maintenance	18
Electrical safety precautions	18
Additional instructions and notes	19
Printed circuit boards	19
Grounding	20
General safety in operation	21
Additional instructions for permanent magnet motor drives	21
Safety in installation, start-up, maintenance	21
Safety in operation	22

2 Introduction to the manual

Contents of this chapter	23
Applicability	23
Target audience	23
Categorization by frame size	23
Quick installation and commissioning flowchart	24
Terms and abbreviations	26
Related manuals	27

3 Operation principle and hardware description

Contents of this chapter	29
Operation principle	29
Simplified main circuit diagram	30
Product variants	30
IEC and UL (NEC) product types	30
Layout	31
Control connections	32
Standard unit (with RIIO-01)	32
Base unit	33
Option modules	33
Control panel options	34
UL Type 1 kits	34
Drive labels	35
Type designation label	35

6 Table of contents

Software information label	36
Type designation key	36
Basic code	36
Option codes	36

4 Mechanical installation

Contents of this chapter	39
Installation alternatives	39
Examining the installation site	40
Required tools	40
Unpacking the delivery	41
Installing the drive	41
To install the drive with screws	41
To install the drive to a DIN installation rail	42

5 Guidelines for planning the electrical installation

Contents of this chapter	45
Limitation of liability	45
North America	45
Selecting the main supply disconnecting device	45
Selecting the main contactor	46
Checking the compatibility of the motor and drive	46
Selecting the power cables	47
General guidelines	47
Typical power cable sizes	47
Power cable types	48
Preferred power cable types	48
Alternate power cable types	49
Not allowed power cable types	50
Additional guidelines – North America	50
Metal conduit	51
Power cable shield	51
Grounding requirements	52
Additional grounding requirements – IEC	53
Additional grounding requirements – UL (NEC)	54
Selecting the control cables	54
Shielding	54
Signals in separate cables	54
Signals that can be run in the same cable	54
Relay cable	55
Control panel to drive cable	55
PC tool cable	55
Routing the cables	55
General guidelines – IEC	55



General guidelines – North America	56
Continuous motor cable shield/conduit and metal enclosure for equipment on the motor cable	57
Separate control cable ducts	58
Implementing short-circuit and thermal overload protection	58
Protecting the drive and input power cable in short-circuits	58
Protecting the motor and motor cable in short-circuits	58
Protecting the drive, and the input power and motor cables against thermal overload	59
Protecting the motor against thermal overload	59
Protecting the motor against overload without thermal model or temperature sensors	59
Implementing a motor temperature sensor connection	60
Protecting the drive against ground faults	60
Residual current device compatibility	60
Implementing the Emergency stop function	60
Implementing the Safe torque off function	61
Using a safety switch between the drive and the motor	61
Implementing the control of a contactor between drive and motor	61
Protecting the contacts of relay outputs	61

6 Electrical installation – IEC

Contents of this chapter	63
Required tools	63
Measuring the insulation resistance - IEC	64
Measuring the insulation resistance of the drive	64
Measuring the insulation resistance of the input power cable	64
Measuring the insulation resistance of the motor and motor cable	64
Measuring the insulation resistance of the brake resistor circuit	65
Grounding system compatibility check – IEC	65
EMC filter	65
Ground-to-phase varistor	66
Compatibility of EMC filter and ground-to-phase varistor with the grounding system	66
Disconnecting the EMC filter or ground-to-phase varistor	68
EMC/VAR screw location	68
Guidelines for installing the drive to a TT system	69
Identifying the grounding system of the electrical power network	69
Connecting the power cables – IEC (shielded cables)	71
Connection diagram	71
Connection procedure	72
Connecting the control cables - IEC	74
Default I/O connection diagrams (ABB standard macro)	74
Default fieldbus connection diagram	76
Control cable connection procedure	77



Additional information on the control connections	78
Embedded EIA-485 fieldbus connection	78
PNP configuration for digital inputs	80
NPN configuration for digital inputs	80
Connection for obtaining 0 ... 10 V from analog output 2 (AO2) .	81
Connection examples of two-wire and three-wire sensors	81
AI and AO (or AI, DI and +10 V) as PTC motor temperature sensor interface	82
AI1 and AI2 as Pt100, Pt1000, Ni1000, KTY83 and KTY84 sensor inputs	84
Safe torque off	85
Auxiliary voltage connection	85
Connecting a PC	86
Installing options	86
Installing a front option	87
Installing a side option	88

 **7 Electrical installation – North America**

Contents of this chapter	91
Required tools	91
Measuring the insulation resistance - North America	92
Measuring the insulation resistance of the drive	92
Measuring the insulation resistance of the input power cable	92
Measuring the insulation resistance of the motor and motor cable	92
Measuring the insulation resistance of the brake resistor circuit	93
Grounding system compatibility check – North America	93
EMC filter	93
Ground-to-phase varistor	94
Compatibility of EMC filter and ground-to-phase varistor with the grounding system	94
Disconnecting the ground-to-phase varistor, or connecting the EMC filter	96
EMC/VAR screw location	96
Guidelines for installing the drive to a TT system	97
Identifying the grounding system of the electrical power network	97
Connecting the power cables – North America (wiring in conduits)	99
Connection diagram	99
Connection procedure	100
Connecting the control cables - North America	102
Default I/O connection diagrams (ABB standard macro)	102
Default fieldbus connection diagram	104
Control cable connection procedure	105
Additional information on the control connections	106
Embedded EIA-485 fieldbus connection	106
PNP configuration for digital inputs	108

- NPN configuration for digital inputs 108
- Connection for obtaining 0 ... 10 V from analog output 2 (AO2) . 109
- Connection examples of two-wire and three-wire sensors 109
- AI and AO (or AI, DI and +10 V) as PTC motor temperature sensor interface 110
- AI1 and AI2 as Pt100, Pt1000, Ni1000, KTY83 and KTY84 sensor inputs 112
- Safe torque off 113
- Auxiliary voltage connection 113
- Connecting a PC 114
- Installing options 114
 - Installing a front option 115
 - Installing a side option 116

8 Installation checklist

- Contents of this chapter 119
- Checklist 119

9 Maintenance

- Contents of this chapter 123
- Maintenance intervals 123
 - Description of symbols 123
 - Recommended maintenance intervals after start-up 124
- Functional safety components 125
- Cleaning the heatsink 125
- Replacing the cooling fans 126
 - Replacing the cooling fan, frames R1...R3 126
 - Replacing the cooling fan, frame R4 127
- Capacitors 129
 - Reforming the capacitors 129

10 Technical data

- Contents of this chapter 131
- Electrical ratings 131
 - IEC ratings 131
 - UL (NEC) ratings 133
 - Definitions 134
 - Sizing 135
- Output derating 135
 - Surrounding air temperature derating 138
 - Altitude derating 138
 - Switching frequency derating 139
 - Derating in case of a phase loss 141



Fuses	142
IEC fuses	142
gG fuses (IEC)	142
gR fuses (IEC)	143
UL (NEC) fuses	145
UL (NEC) fuse alternatives	147
Alternative short-circuit protection	151
Miniature circuit breakers (IEC)	151
Miniature circuit breakers (UL)	153
Manual self-protected combination motor controller – Type E USA (UL (NEC))	155
Dimensions and weights	157
Free space requirements	158
Losses, cooling data and noise	158
Typical power cable sizes	160
Terminal data for the power cables	163
Terminal data for the control cables	166
Electrical power network specification	166
Motor connection data	167
Motor cable length	168
Operational functionality and motor cable length	168
EMC compatibility and motor cable length	168
Brake resistor connection data	169
Control connection data	170
Energy efficiency data (ecodesign)	171
Protection classes	171
Ambient conditions	171
Storage conditions	173
Materials	173
Drive	173
Drive package	173
Package materials for options, accessories and spare parts	173
Materials of manuals	174
Disposal	174
Applicable standards	174
Markings	175
Compliance with the harmonic current limits in a public network (IEC/EN 61000 3-2, IEC/EN 61000-3-12)	176
3-phase 230 V, 400 V or 480 V drive with the input choke	176
3-phase 230 V, 400 V or 480 V drive without the input choke	177
1-phase 230 V drive with or without the input choke	177
EMC compliance (IEC/EN 61800-3:2004 + A1:2012)	177
Definitions	177
Category C1	178
Category C2	178



Category C3	179
Category C4	179
UL checklist	180
Disclaimers	181
Generic disclaimer	181
Cyber security disclaimer	181
Declarations of conformity	182

11 Dimension drawings

Contents of this chapter	183
Frame R0	184
Frame R0 (front & side) - IP20 / UL open type	184
Frame R0 (bottom & rear) - IP20 / UL open type	185
Frame R1	186
Frame R1 (front & side) - IP20 / UL open type	186
Frame R1 (bottom & rear) - IP20 / UL open type	187
Frame R1 (front & side) - UL Type 1 kit installed	188
Frame R1 (bottom & rear) - UL Type 1 kit installed	189
Frame R2	190
Frame R2 (front & side) - IP20 / UL open type	190
Frame R2 (bottom & rear) - IP20 / UL open type	191
Frame R2 (front & side) - UL Type 1 kit installed	192
Frame R2 (bottom & rear) - UL Type 1 kit installed	193
Frame R3	194
Frame R3 (front & side) - IP20 / UL open type	194
Frame R3 (bottom & rear) - IP20 / UL open type	195
Frame R3 (front & side) - UL Type 1 kit installed	196
Frame R3 (bottom & rear) - UL Type 1 kit installed	197
Frame R4	198
Frame R4 (front & side) - IP20 / UL open type	198
Frame R4 (bottom & rear) - IP20 / UL open type	199
Frame R4 (front & side) - UL Type 1 kit installed	200
Frame R4 (bottom & rear) - UL Type 1 kit installed	201

12 Input chokes

Contents of this chapter	203
When is an input choke necessary?	203
Maximum input current	203
IEC	204
UL (NEC)	205
Selecting an input choke	205
Guidelines for installing an input choke	207
Connection diagram	208
Dimensions	208



13 External EMC filters

Contents of this chapter 211
Selecting the external EMC filter 211

14 Resistor braking

Contents of this chapter 215
Safety 215
Operation principle 215
Selecting the brake resistor 215
 Reference brake resistors 217
 Definitions 220
Selecting and routing the brake resistor cables 220
 Minimizing electromagnetic interference 220
 Maximum cable length 220
Selecting the installation location for the brake resistors 220
Protecting the system in brake circuit fault situations 221
 Protecting the system in cable and brake resistor short-circuit
 situations 221
 Protecting the system against thermal overload 221
Mechanical and electrical installation of brake resistor 222
 Mechanical installation 222
 Electrical installation 223
 Measuring the insulation 223
 Connecting power cables 223
 Connection the control cables 223
Start-up 223

15 The Safe torque off function

Contents of this chapter 225
Description 225
 Compliance with the European Machinery Directive and the UK Supply
 of Machinery (Safety) Regulations 226
Wiring 227
 Connection principle 227
 Single ACS480 drive, internal power supply 227
 Single ACS480 drive, external power supply 228
Wiring examples 229
 Single ACS480 drive, internal power supply 229
 Single ACS480 drive, external power supply 229
 Multiple ACS480 drives, internal power supply 230
 Multiple ACS480 drives, external power supply 231
Activation switch 231
Cable types and lengths 232



Grounding of protective shields	232
Operation principle	233
Start-up including validation test	234
Competence	234
Validation test reports	234
Validation test procedure	234
Use	236
Maintenance	238
Competence	238
Fault tracing	239
Safety data	240
Terms and abbreviations	242
TÜV certificate	243

16 BAPO-01 auxiliary power extension module

Contents of this chapter	245
Safety instructions	245
Hardware description	245
Layout	246
Mechanical installation	247
Electrical installation	247
Start-up	248
Technical data	248

17 BIO-01 I/O extension module

Contents of this chapter	249
Safety instructions	249
Hardware description	249
Product overview	249
Layout	250
Mechanical installation	250
Terminal configuration	250
Electrical installation	251
Start-up	251
Technical data	252

18 BREL-01 relay output extension module

Contents of this chapter	255
Safety instructions	255
Hardware description	255
Product overview	255
Layout	256
Mechanical installation	256



14 Table of contents

Electrical installation 256
Start-up 257
Configuration parameters 257
Technical data 260

Further information



1

Safety instructions

Contents of this chapter

This chapter contains the safety instructions which you must obey when you install, start-up, operate and do maintenance work on the drive. If you ignore the safety instructions, injury, death or damage can occur.



Use of warnings and notes

Warnings tell you about conditions which can cause injury or death, or damage to the equipment. They also tell you how to prevent the danger. Notes draw attention to a particular condition or fact, or give information on a subject.

The manual uses these warning symbols:

**WARNING!**

Electricity warning tells about hazards from electricity which can cause injury or death, or damage to the equipment.

**WARNING!**

General warning tells about conditions other than those caused by electricity, which can cause injury or death, or damage to the equipment.

**WARNING!**

Electrostatic sensitive devices warning tells you about the risk of electrostatic discharge which can cause damage to the equipment.

General safety in installation, start-up and maintenance

These instructions are for all personnel who do work on the drive.



WARNING!

Obey these instructions. If you ignore them, injury or death, or damage to the equipment can occur.

- Keep the drive in its package until you install it. After unpacking, protect the drive from dust, debris and moisture.
 - Use the required personal protective equipment: safety shoes with metal toe cap, safety glasses, protective gloves and long sleeves, etc. Some parts have sharp edges.
 - Beware of hot surfaces. Some parts, such as heatsinks of power semiconductors, and brake resistors, remain hot for a while after disconnection of the electrical supply.
 - Vacuum clean the area around the drive before the start-up to prevent the drive cooling fan from drawing dust inside the drive.
 - Make sure that debris from drilling, cutting and grinding does not go into the drive during installation. Electrically conductive debris inside the drive can cause damage or malfunction.
 - Make sure that there is sufficient cooling. See the technical data.
 - Before you connect voltage to the drive, make sure that all covers are in place. Do not remove the covers when voltage is connected.
 - Before you adjust the drive operation limits, make sure that the motor and all driven equipment can operate throughout the set operation limits.
 - Before you activate the automatic fault reset or automatic restart functions of the drive control program, make sure that no dangerous situations can occur. These functions reset the drive automatically and continue operation after a fault or supply break. If these functions are activated, the installation must be clearly marked as defined in IEC/EN/UL 61800-5-1, subclause 6.5.3, for example, "THIS MACHINE STARTS AUTOMATICALLY".
 - The maximum number of drive power-ups is five in ten minutes. Too frequent power-ups can damage the charging circuit of the DC capacitors.
 - If you have connected safety circuits to the drive (for example, Safe torque off or emergency stop), validate them at start-up. See separate instructions for the safety circuits.
 - Beware of hot air exiting from the air outlets.
 - Do not cover the air inlet or outlet when the drive is running.
-



Note:

- If you select an external source for the start command and it is on, the drive will start immediately after fault reset unless you configure the drive for pulse start. See the firmware manual.
- If the drive is in remote control mode, you cannot stop or start the drive with the control panel.
- Only authorized persons are allowed to repair a malfunctioning drive.



Electrical safety in installation, start-up and maintenance

■ Electrical safety precautions

These electrical safety precautions are for all personnel who do work on the drive, motor cable or motor.



WARNING!

Obey these instructions. If you ignore them, injury or death, or damage to the equipment can occur.

If you are not a qualified electrical professional, do not do installation or maintenance work.

Do these steps before you begin any installation or maintenance work.

1. Prepare for the work.
 - Make sure that you have a work order.
 - Do an on-site risk assessment or job hazard analysis.
 - Make sure that you have the correct tools available.
 - Make sure that the workers are qualified.
 - Select the correct personal protective equipment (PPE).
 - Stop the motor(s).
 2. Clearly identify the work location and equipment.
 3. Disconnect all possible voltage sources. Make sure that re-connection is not possible. Lock out and tag out.
 - Open the main disconnecting device of the drive.
 - If you have a permanent magnet motor connected to the drive, disconnect the motor from the drive with a safety switch or by other means.
 - Open the main isolating device of the drive.
 - Disconnect all dangerous external voltages from the control circuits.
 - After you disconnect power from the drive, always wait 5 minutes to let the intermediate circuit capacitors discharge before you continue.
 4. Protect other energized parts in the work location against contact and take special precautions when close to bare conductors.
 5. Measure that the installation is de-energized. Use a quality voltage tester.
 - Before and after you measure the installation, verify the operation of the voltage tester on a known voltage source.
 - Make sure that the voltage between the drive input power terminals (L1, L2, L3) and the grounding (PE) busbar is zero.
 - Make sure that the voltage between the drive output terminals (U, V, W) and the grounding (PE) busbar is zero.
 - Make sure that the voltage between the drive DC terminals (UDC+ and UDC-) and the grounding (PE) terminal is zero.
-



Note: If cables are not connected to the drive DC terminals, measuring the voltage from the DC terminal screws can give incorrect results.

6. Install temporary grounding as required by the local regulations.
7. Ask for a permit to work from the person in control of the electrical installation work.

■ Additional instructions and notes



WARNING!

Obey these instructions. If you ignore them, injury or death, or damage to the equipment can occur.

If you are not a qualified electrical professional, do not do installation or maintenance work.

- Make sure that the electrical power network, motor/generator, and environmental conditions agree with the drive data.
- Do not do insulation or voltage withstand tests on the drive.
- If you have a cardiac pacemaker or other electronic medical device, keep away from the area near motor, drive, and the drive power cabling when the drive is in operation. There are electromagnetic fields present which can interfere with the function of such devices. This can cause a health hazard.



Note:

- When the drive is connected to the input power, the motor cable terminals and the DC bus are at a dangerous voltage.
The brake circuit, including the brake chopper and brake resistor (if installed) are also at a dangerous voltage.
After disconnecting the drive from the input power, these remain at a dangerous voltage until the intermediate circuit capacitors have discharged.
- External wiring can supply dangerous voltages to the relay outputs of the control units of the drive.
- The Safe torque off function does not remove the voltage from the main and auxiliary circuits. The function is not effective against deliberate sabotage or misuse.

Printed circuit boards



WARNING!

Use a grounding wristband when you handle printed circuit boards. Do not touch the boards unnecessarily. The boards contain components sensitive to electrostatic discharge.

■ Grounding

These instructions are for all personnel who are responsible for the grounding of the drive.



WARNING!

Obey these instructions. If you ignore them, injury or death, or equipment malfunction can occur, and electromagnetic interference can increase.

If you are not a qualified electrical professional, do not do grounding work.

- Always ground the drive, the motor and adjoining equipment. This is necessary for the personnel safety.
- Make sure that the conductivity of the protective earth (PE) conductors is sufficient and that other requirements are met. See the electrical planning instructions of the drive. Obey the applicable national and local regulations.
- When using shielded cables, make a 360° grounding of the cable shields at the cable entries to reduce electromagnetic emission and interference.
- In a multiple-drive installation, connect each drive separately to the protective earth (PE) busbar of the power supply.



General safety in operation

These instructions are for all personnel that operate the drive.



WARNING!

Obey these instructions. If you ignore them, injury or death, or damage to the equipment can occur.

- If you have a cardiac pacemaker or other electronic medical device, keep away from the area near motor, drive, and the drive power cabling when the drive is in operation. There are electromagnetic fields present which can interfere with the function of such devices. This can cause a health hazard.
- Give a stop command to the drive before you reset a fault. If you have an external source for the start command and the start is on, the drive will start immediately after the fault reset, unless you configure the drive for pulse start. See the firmware manual.
- Before you activate the automatic fault reset or automatic restart functions of the drive control program, make sure that no dangerous situations can occur. These functions reset the drive automatically and continue operation after a fault or supply break. If these functions are activated, the installation must be clearly marked as defined in IEC/EN/UL 61800-5-1, subclause 6.5.3, for example, "THIS MACHINE STARTS AUTOMATICALLY".

Note:

- The maximum number of drive power-ups is five in ten minutes. Too frequent power-ups can damage the charging circuit of the DC capacitors. If you need to start or stop the drive, use the control panel keys or commands through the I/O terminals of the drive or the fieldbus interface.
- If the drive is in remote control mode, you cannot stop or start the drive with the control panel.

Additional instructions for permanent magnet motor drives

■ Safety in installation, start-up, maintenance

These are additional warnings concerning permanent magnet motor drives. The other safety instructions in this chapter are also valid.



WARNING!

Obey these instructions. If you ignore them, injury or death, or damage to the equipment can occur.

If you are not a qualified electrical professional, do not do installation or maintenance work.

22 Safety instructions

- Do not do work on the drive when a rotating permanent magnet motor is connected to it. A rotating permanent magnet motor energizes the drive including its input and output power terminals.

Before installation, start-up and maintenance work on the drive:

- Stop the drive.
- Disconnect the motor from the drive with a safety switch or by other means.
- If you cannot disconnect the motor, make sure that the motor cannot rotate during work. Make sure that no other system, like hydraulic crawling drives, can rotate the motor directly or through any mechanical connection like belt, nip, rope, etc.
- Do the steps in section [Electrical safety precautions \(page 18\)](#).
- Install temporary grounding to the drive output terminals (T1/U, T2/V, T3/W). Connect the output terminals together as well as to the PE.

During the start-up:

- Make sure that the motor cannot run overspeed, for example, driven by the load. Motor overspeed causes overvoltage that can damage or destroy the capacitors in the intermediate circuit of the drive.



■ Safety in operation



WARNING!

Make sure that the motor cannot run overspeed, for example, driven by the load. Motor overspeed causes overvoltage that can damage or destroy the capacitors in the intermediate circuit of the drive.



Introduction to the manual

Contents of this chapter

The chapter describes the applicability, target audience and purpose of the manual. The chapter contains a list of related manuals and a flowchart for installation and commissioning.

Applicability

This manual is applicable to ACS480 drives.

Target audience

This manual is intended for people who plan the installation, install, commission and do maintenance work on the drive, or create instructions for the end user of the drive concerning the installation and maintenance of the drive.

Read the manual before you work on the drive. You are expected to know the fundamentals of electricity, wiring, electrical components and electrical schematic symbols.

Categorization by frame size

The drives are manufactured in frame sizes (for example, R1). The information that is applicable only to specific frames is identified with the frame size. The frame size is shown on the type designation label.

Quick installation and commissioning flowchart

Task	See
Identify the frame size: R0, R1, R2, etc.	Type designation key (page 36)
Plan the installation. Check the ambient conditions, ratings and required cooling air flow.	Guidelines for planning the electrical installation (page 45) Technical data (page 131)
Unpack and check the delivery.	Unpacking the delivery (page 41)
If the supply network is not a symmetrically grounded TN-S system, make sure that the drive is compatible with the grounding system.	Grounding system compatibility check – IEC (page 65) Grounding system compatibility check – North America (page 93)
Install the drive.	Installing the drive (page 41)
Route the cables.	Routing the cables (page 55)
Measure the insulation of the input cable, motor and motor cable.	Measuring the insulation resistance - IEC (page 64) Measuring the insulation resistance - North America (page 92)
Connect the power cables.	Connecting the power cables – IEC (shielded cables) (page 71) Connecting the power cables – North America (wiring in conduits) (page 99)
Connect the control cables.	Connecting the control cables - IEC (page 74) Connecting the control cables - North America (page 102)
Examine the installation.	Installation checklist (page 119)

Task

See

Commission the drive.

Refer to [ACS480 Quick installation and start-up guide \(3AXD50000047400 \[English\]\)](#) and [ACS480 Firmware manual \(3AXD50000047399 \[English\]\)](#).

Terms and abbreviations

Term	Description
ACS-AP-I	Industrial assistant non-Bluetooth control panel
ACS-AP-S	Standard assistant control panel
ACS-AP-W	Industrial assistant control panel with Bluetooth interface
ACS-BP-S	Basic control panel
BAPO	Optional auxiliary power extension module
BCBL-01	Optional USB to RJ45 cable
BIO-01	Optional I/O extension module. Can be installed to the drive together with a fieldbus adapter module.
Brake chopper	Conducts the surplus energy from the intermediate circuit of the drive to the brake resistor when necessary. The chopper operates when the DC link voltage exceeds a certain maximum limit. The voltage rise is typically caused by deceleration (braking) of a high inertia motor.
Brake resistor	Dissipates the drive surplus braking energy conducted by the brake chopper to heat
BREL	Optional relay output extension module
Capacitor bank	The capacitors connected to the DC link
CCA-01	Configuration adapter
CDPI-01	Communication adapter module
Control unit	The part in which the control program runs.
DC link	DC circuit between rectifier and inverter
DC link capacitors	Energy storage which stabilizes the intermediate circuit DC voltage
Drive	Frequency converter for controlling AC motors
EFB	Embedded fieldbus
EMC	Electromagnetic compatibility
FBA	Fieldbus adapter
FCAN	Optional CANopen® adapter module
FCNA-01	Optional ControlNet™ adapter module
FDNA-01	Optional DeviceNet™ adapter module
FECA-01	Optional EtherCAT® adapter module
FEIP-21	Optional Ethernet adapter module for EtherNet/IP™
FENA-21	Optional Ethernet adapter module for EtherNet/IP™, Modbus TCP and PROFINET IO protocols, 2-port
FEPL-02	Optional Ethernet POWERLINK adapter module
FMBT-21	Optional Ethernet adapter module for Modbus TCP protocol
FPBA-01	Optional PROFIBUS DP® adapter module
FPNO-21	Optional PROFINET IO adapter module
Frame, frame size	Physical size of the drive or power module
Intermediate circuit	DC circuit between rectifier and inverter

Term	Description
Inverter	Converts direct current and voltage to alternating current and voltage.
Macro	A pre-defined set of default values of parameters in a drive control program.
NETA-21	Remote monitoring tool
Parameter	In the drive control program, user-adjustable operation instruction to the drive, or signal measured or calculated by the drive. In some (for example fieldbus) contexts, a value that can be accessed as an object. For example, variable, constant, or signal.
PLC	Programmable logic controller
RDUM-01	Optional blank control panel cover
RFI	Radio-frequency interference
RIO-01	I/O & EIA-485 module
SIL	Safety integrity level (1...3) (IEC 61508, IEC 62061, IEC 61800-5-2)
STO	Safe torque off (IEC/EN 61800-5-2)

Related manuals

You can find manuals on the Internet. See below for the relevant code/link. For more documentation, go to www.abb.com/drives/documents.



[ACS480 manuals](#)



3

Operation principle and hardware description

Contents of this chapter

This chapter briefly describes the operation principle and construction of the drive.

Operation principle

The ACS480 is a drive for controlling asynchronous AC induction motors, permanent magnet synchronous motors and ABB synchronous reluctance motors (SynRM motors). The drive is optimized for cabinet installation.

■ **Simplified main circuit diagram**

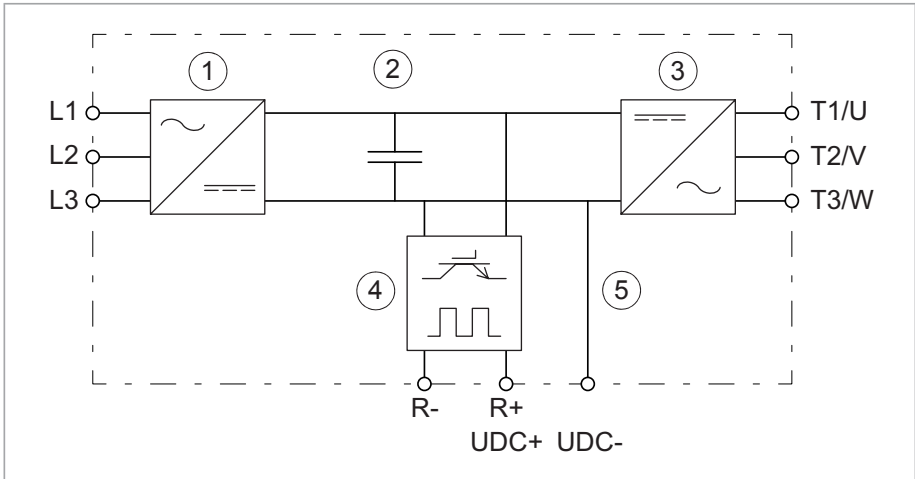

1	Rectifier. Converts alternating current and voltage to direct current and voltage.
2	DC link. DC circuit between rectifier and inverter.
3	Inverter. Converts direct current and voltage to alternating current and voltage.
4	Brake chopper. Conducts energy from the intermediate DC circuit of the drive to the brake resistor when it is necessary and if an external brake resistor is connected to the drive. The chopper operates when the DC link voltage exceeds a certain maximum limit. The voltage rise is typically caused by deceleration (braking) of a motor. The user obtains and installs the brake resistor when necessary.
5	DC connection (UDC+, UDC-).

Product variants

The drive has two product variants:

- Standard unit: drive with assistant control panel and RIIO-01 I/O & EIA-485 module
- Base unit: drive without control panel and without RIIO-01 I/O & EIA-485 module (option +0J400+0L540) .

■ **IEC and UL (NEC) product types**

The ACS480 series consists of IEC product types and UL (NEC) product types. The IEC types are designed for global use. The UL (NEC) types are specifically designed for use in North America.

Layout

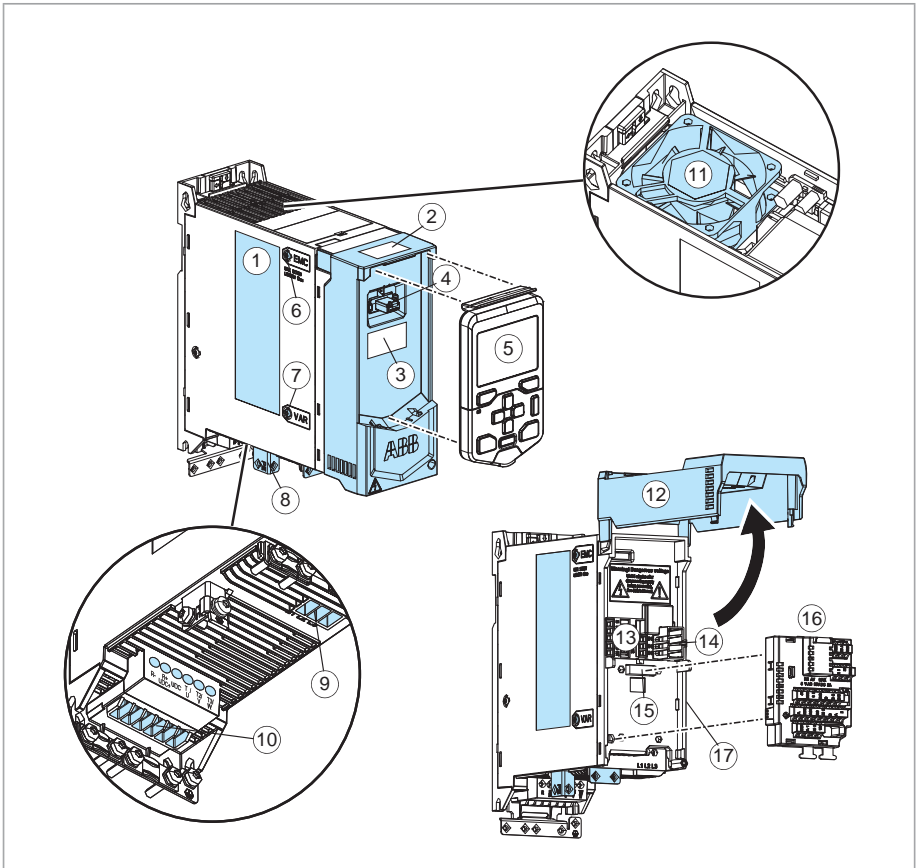

1	Type designation label	10	Motor and brake resistor terminals
2	Model information label	11	Cooling fan (on frames R1...R4)
3	Firmware information label	12	Front cover
4	Control panel connection	13	Control terminals
5	Control panel	14	Cold configuration adapter connection (CCA-01)
6	EMC filter grounding screw	15	Front option slot
7	Varistor grounding screw	16	Front option module
8	PE connection (motor)	17	Side option slot for side-mounted options
9	Input power terminals		

Control connections

There are fixed control connections on the base unit and additional control connections on the installed option module.

■ Standard unit (with RIIO-01)

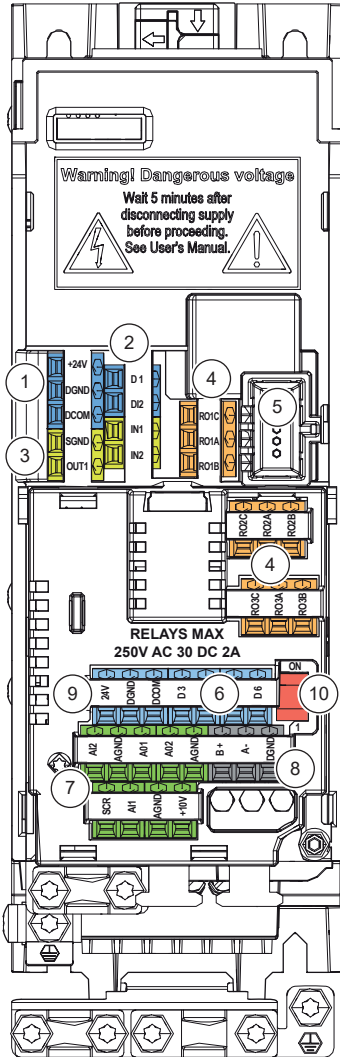

Connections of the base unit:

1. Auxiliary voltage output
2. Digital inputs
3. Safe torque-off connections
4. Relay output connections
5. Cold configuration adapter connection for CCA-01

Connections of the RIIO-01 I/O & EIA-485 module:

6. Digital inputs
7. Analog inputs and outputs
8. Embedded fieldbus EIA-485 (Modbus RTU)
9. Auxiliary voltage output
10. EIA-485 end of line termination switch

■ **Base unit**

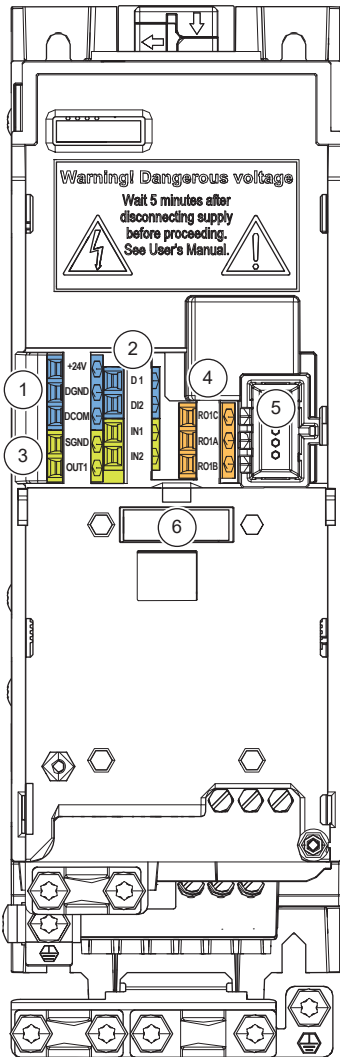

Connections of the base unit:

1. Auxiliary voltage output
2. Digital inputs
3. Safe torque-off connections
4. Relay output connection
5. Cold configuration adapter connection for CCA-01
6. Front option module slot 1

Option modules

The drive supports optional extension modules on the front and on the right side. Refer to [Type designation key \(page 36\)](#).

Control panel options

The drive supports these control panels:

- ACS-AP-S assistant control panel
- ACS-AP-W assistant control panel with Bluetooth
- ACS-AP-I assistant control panel
- ACS-BP-S basic control panel
- RDUM-01 blank panel with RJ-45 connector
- CDPI-02 panel bus adapter (blank panel with two RJ-45 connectors for the panel bus).

In addition, you can order a control panel platform for cabinet door installation. These panel platforms are available:

Type	Description
DPMP-01	Control panel mounting platform (flush mounting) and cable ¹⁾
DPMP-02	Control panel mounting platform (surface mounting) and cable ¹⁾
DPMP-EXT2	DPMP-02 panel mounting platform (and cable) and RDUM-01 blank panel with RJ-45 connector

¹⁾ You need also RDUM-01 blank panel, or CDPI-02 panel bus adapter to connect the panel cable at the drive end.

UL Type 1 kits

There are UL Type 1 kit options available for the drive. For the ordering codes and installation instructions, refer to the table that follows.

Frame size	Option code	Installation instructions
R0	3AXD50000187034	UL Type 1 kit for ACS380, ACS480 and ACH480 installation guide, frames R0 to R2 (3AXD50000235254)
R1	3AXD50000176779	
R2	3AXD50000178780	
R3	3AXD50000179220	UL Type 1 kit for ACS380, ACS480 and ACH480 installation guide, frames R3 to R4 (3AXD50000242375)
R4	3AXD50000179336	

Drive labels

The drive has these labels:

- type designation label on the left side of the drive
- model information label on the top of the drive
- software information label under the control panel.

Example labels are shown in this section.

■ Type designation label

<p> ABB ① ACS480-04-07A3-4 ② Origin China Made in China ABB Oy Hiomotie 13 00380 Helsinki Finland ③ FRAME R1 ④ Air cooling Icc 65 kA SCCR 100 kA ⑥ IP20 Multi-rated equipment, see Hardware Manual UL open type UL type 1 with option - see manual ⑦ IEC (90/100) 2,0 % ⑧ Input U1 3~ 400-480 VAC U2 50 / 60 Hz Output In 7.2-6 A Ild 6.8-6 A Ihd 5.6-4 A f2 0-500 Hz Input current is scaled by motor output current <table border="1"> <thead> <tr> <th></th> <th>Output</th> <th>Input</th> <th>Input (with 5% choke)</th> </tr> </thead> <tbody> <tr> <td>In</td> <td>7.2.. 6</td> <td>11.5.. 9.6</td> <td>7.2.. 6</td> </tr> <tr> <td>Ild</td> <td>6.8.. 6</td> <td>10.9.. 9.6</td> <td>6.8.. 6</td> </tr> <tr> <td>Ihd</td> <td>5.6.. 4</td> <td>9.. 6.4</td> <td>5.6.. 4</td> </tr> </tbody> </table> ⑩ CE, EAC, UK CA, Safety Approved, UL US LISTED, R-REI-Abb-ACS480-09A5-4, ⑪ S/N: 42322A0511 </p>			Output	Input	Input (with 5% choke)	In	7.2.. 6	11.5.. 9.6	7.2.. 6	Ild	6.8.. 6	10.9.. 9.6	6.8.. 6	Ihd	5.6.. 4	9.. 6.4	5.6.. 4
	Output	Input	Input (with 5% choke)														
In	7.2.. 6	11.5.. 9.6	7.2.. 6														
Ild	6.8.. 6	10.9.. 9.6	6.8.. 6														
Ihd	5.6.. 4	9.. 6.4	5.6.. 4														
1	Type designation, see section Type designation key (page 36) .																
2	Contact address																
3	Frame (size)																
4	Cooling method																
5	Short-circuit withstand strength, see section Electrical power network specification (page 166) .																
6	Degree of protection																
7	Losses according to IEC 61800-9-2																
8	Nominal ratings in the supply voltage range, Electrical ratings (page 131) .																
9	Link to product information page																
10	Valid markings																
11	S/N: Serial number of format MYYWWXXXX, where M: Manufacturer YY: Year of manufacture: 19, 20, 21, ... for 2019, 2020, 2021, ... WW: Week of manufacture: 01, 02, 03, ... for week 1, week 2, week 3, ... XXXX: Running item number that starts each week from 0001.																

■ Software information label

①	ACS480-04-07A3-4 3~ 400/480 V (Frame R1)
②	Pld: 3 kW (3 hp) Phd: 2.2 kW (3 hp)
③	S/N: 41940A0620 SW v2.14.0.0
1	Drive type
2	Frame size and ratings
3	Serial number and drive software version

Type designation key

The type designation key shows the specifications and the configuration of the drive.

■ Basic code

Type code example: ACS480-04-12A7-4

Code	Description
ACS480	Product series
04	Construction. 04 = Module When no options are selected: cabinet optimized module, IP20 (UL open type), ACS-AP-S assistant control panel, RIIO-01 I/O & EIA-485 module, EMC category C2 filter, Safe torque off, brake chopper, coated boards, quick installation and start-up guide.
12A7	Size. See the ratings table in the technical data.
4	Input voltage. <ul style="list-style-type: none"> • 1 = 1-phase 200 ... 240 V AC • 2 = 3-phase 200 ... 240 V AC • 4 = 3-phase 380 ... 480 V AC

■ Option codes

Code	Description
0J400	No control panel
J400	ACS-AP-S control panel (included as standard)
J424	Blank control panel cover (no control panel)

Code	Description
J425	ACS-AP-I control panel
J429	ACS-AP-W control panel with Bluetooth interface
K451	FDNA-01 DeviceNet™ adapter module
K454	FPBA-01 PROFIBUS DP adapter module
K457	FCAN-01 CANopen adapter module
K458	FSCA-01 RS-485 (Modbus/RTU) adapter module
K469	FECA-01 EtherCat adapter module
K470	FEPL-02 EtherPOWERLINK adapter module
K475	FENA-21 Ethernet adapter module for EtherNet/IP™, Modbus TCP and PROFINET IO protocols, 2-port
K491	FMBT-21 Modbus/TCP adapter module
K492	FPNO-21 PROFINET IO adapter module
L511	BREL-01 relay output extension module
L515	BIO-01 I/O extension module (front option, can be used with fieldbus)
L534	BAPO-01 external 24 V DC power extension module (side option)
L540	RIIO-01 I/O & EIA-485 module (front option, as standard)
OL540	Base unit without RIIO-01 I/O & EIA-485 module
R700	Printed manuals in English
R701	Printed manuals in German ¹⁾
R702	Printed manuals in Italian ¹⁾
R703	Printed manuals in Dutch ¹⁾
R704	Printed manuals in Danish ¹⁾
R705	Printed manuals in Swedish ¹⁾
R706	Printed manuals in Finnish ¹⁾
R707	Printed manuals in French ¹⁾

38 Operation principle and hardware description

Code	Description
R708	Printed manuals in Spanish ¹⁾
R709	Printed manuals in Portuguese ¹⁾
R711	Printed manuals in Russian ¹⁾
R712	Printed manuals in Chinese ¹⁾
R713	Printed manuals in Polish ¹⁾
R714	Printed manuals in Turkish ¹⁾

¹⁾ Manuals in English may be included if a translation in the specified language is not available.

4

Mechanical installation

Contents of this chapter

This chapter tells how to examine the installation site, unpack and examine the delivery and install the drive mechanically.

Installation alternatives

You can install the drive:

- with screws on to a wall
- with screws on to an assembly plate
- on to a DIN installation rail (IEC/EN 60715, top hat type, width 35 mm [1.4 in] × height 7.5 mm [0.3 in]).

Installation requirements:

- The drive is designed for cabinet installation and has a degree of protection of IP20 / UL open type as standard. A UL Type 1 kit is available as an option.
- Make sure that there is a minimum of 75 mm (3 in) of free space at the top and bottom of the drive (at the cooling air inlet and outlet), measured from the frame.

With the optional UL Type 1 kit, make sure that there is a minimum of 50 mm (2 in) of free space at the top (measured from the top of the hood) and 75 mm (3 in) at the bottom of the drive.

- You can install several drives side by side.
 - Install R0 drives vertically, because they do not have a cooling fan.
-



40 Mechanical installation

- You can install frames R1, R2, R3 and R4 tilted to a maximum of 90 degrees, from vertical to fully horizontal orientation.
- Do not install the drive upside down.

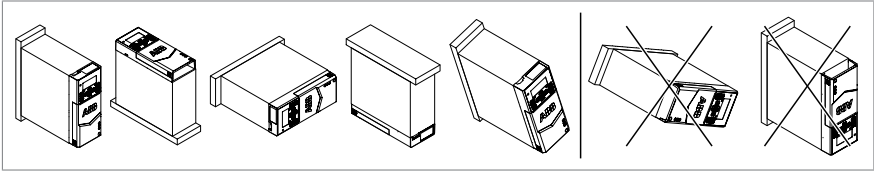

- Make sure that the hot exhaust air from a drive does not flow into the cooling inlet of other drives or equipment.
- Drives equipped with the optional UL Type 1 kits: If you install the drives side-by-side, make sure that their air outlets do not face each other.

Examining the installation site

Examine the installation site. Make sure that:

- The installation site is sufficiently ventilated or cooled to remove heat from the drive. See the technical data.
- The ambient conditions of the drive meet the specifications. See the technical data.
- The material behind, above and below the drive is non-flammable.
- The installation surface is as close to vertical as possible and strong enough to support the drive.
- There is sufficient free space around the drive for cooling, maintenance, and operation. See the free space specifications for the drive.
- Make sure that there are no sources of strong magnetic fields such as high-current single-core conductors or contactor coils near the drive. A strong magnetic field can cause interference or inaccuracy in the operation of the drive.

Required tools

To install the drive mechanically, you need these tools:

- a drill and suitable drill bits
 - a screwdriver or wrench with a set of suitable bits
 - a tape measure and spirit level
 - personal protective equipment.
-

Unpacking the delivery

Keep the drive in its package until you are ready to install it. After unpacking, protect the drive from dust, debris and moisture.

Make sure that these items are included:

- drive
- options, if ordered with an option code
- assistant control panel (not installed)
- RIIO-01 I/O & EIA-485 module (not installed)
Note: If a fieldbus adapter is ordered, it replaces the RIIO-01 I/O & EIA-485 module of the standard delivery.
- mounting template (drives with frame size R3 or R4 only)
- installation accessories (cable clamps, cable ties, hardware)
- multilingual warning sticker sheet (residual voltage warning)
- safety instructions
- quick installation and start-up guide
- hardware and firmware manuals, if ordered with an option code.

Make sure that there are no signs of damage to the items.

Installing the drive

■ To install the drive with screws

1. Make marks onto the surface for the mounting holes. Use the included mounting template for frames R3 and R4. For other frames, see the dimension drawings.
2. Drill the holes for the mounting screws.
3. If necessary, install anchors or plugs into the holes.



42 Mechanical installation

4. Install the mounting screws into the holes. Leave a gap between the screw head and installation surface.

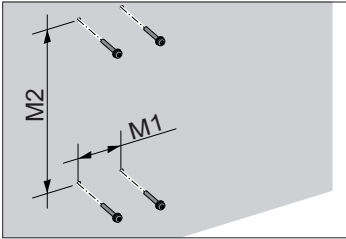

5. Put the drive onto the mounting screws.
6. Tighten the mounting screws.

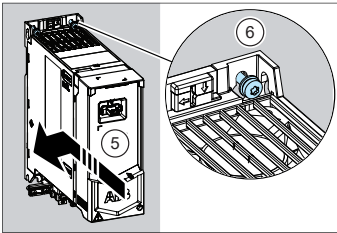

■ To install the drive to a DIN installation rail

Use an IEC/EN 60715 top hat type installation rail, width × height = 35 × 7.5 mm (1.4 × 0.3 in).

1. Move the locking part to the left.

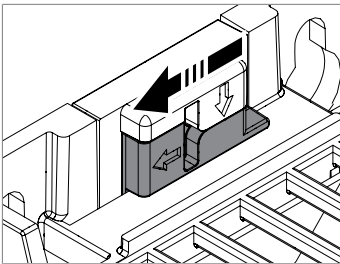

2. Push and hold the locking button down.

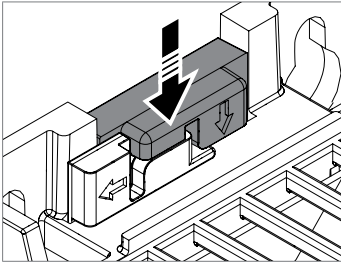

3. Put the top tabs of the drive onto the top edge of the DIN installation rail.
4. Put the drive against the bottom edge of the DIN installation rail.
5. Release the locking button.
6. Move the locking part to the right.
7. Make sure that the drive is correctly installed.

To remove the drive, use a flat-head screwdriver to open the locking part.



5

Guidelines for planning the electrical installation

Contents of this chapter

This chapter contains guidelines for planning the electrical installation of the drive.

Limitation of liability

The installation must always be designed and made according to applicable local laws and regulations. ABB does not assume any liability whatsoever for any installation which breaches the local laws and/or other regulations. Furthermore, if the recommendations given by ABB are not followed, the drive may experience problems that the warranty does not cover.

■ North America

Installations must be compliant with NFPA 70 (NEC)¹⁾ and/or Canadian Electrical Code (CE) along with state and local codes for your location and application.

¹⁾ National Fire Protection Association 70 (National Electric Code).

Selecting the main supply disconnecting device

You must equip the drive with a main supply disconnecting device which meets the local safety regulations. You must be able to lock the disconnecting device to the open position for installation and maintenance work.

To comply with European Union directives and United Kingdom regulations related to standard EN 60204-1, the disconnecting device must be one of these types:

- switch-disconnector of utilization category AC-23B (IEC 60947-3)
- disconnector that has an auxiliary contact that in all cases causes switching devices to break the load circuit before the opening of the main contacts of the disconnector (EN 60947-3)
- circuit-breaker suitable for isolation in accordance with IEC 60947-2.

Selecting the main contactor

You can equip the drive with a main contactor.

Follow these guidelines when you select a customer-defined main contactor:

- Dimension the contactor according to the nominal voltage and current of the drive. Also consider the environmental conditions such as surrounding air temperature.
- IEC installations: Select contactor with utilization category AC-1 (number of operations under load) according to IEC 60947-4.
- Consider the application life time requirements.

Checking the compatibility of the motor and drive

Use asynchronous AC induction motor, permanent magnet synchronous motor or ABB synchronous reluctance motor (SynRM motors) with the drive. Multiple induction motors can be connected to the drive at a time when using the scalar motor control mode.

Make sure that the motor(s) and the drive are compatible according to the rating table in the technical data.

Selecting the power cables

■ General guidelines

Select the input power and motor cables according to local regulations.

- **Current:** Select a cable capable of carrying the maximum load current and suitable for the prospective short-circuit current provided by the supply network. The method of installation and ambient temperature affect the cable current carrying capacity. Obey local regulations and laws.
- **Temperature:** For an IEC installation, select a cable rated for at least 70 °C (158 °F) maximum permissible temperature of conductor in continuous use. For North America, select a cable rated for at least 75 °C (167 °F).
Important: For certain product types or option configurations higher temperature rating may be required. See the technical data for details.
- **Voltage:** 600 V AC cable is accepted for up to 500 V AC. 750 V AC cable is accepted for up to 600 V AC. 1000 V AC cable is accepted for up to 690 V AC.

To comply with the EMC requirements of the CE mark, use one of the preferred cable types. See [Preferred power cable types \(page 48\)](#).

Symmetrical shielded cable reduces electromagnetic emission of the whole drive system as well as the stress on motor insulation, bearing currents and wear.

Metal conduit reduces electromagnetic emission of the whole drive system.

■ Typical power cable sizes

See the technical data.

■ **Power cable types**

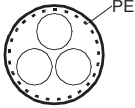
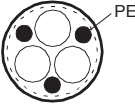
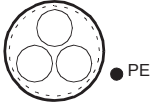

Preferred power cable types

This section shows the preferred cable types. Make sure that the selected cable type also complies with local/state/country electrical codes.

Cable type	Use as input power cabling	Use as motor cabling and as brake resistor cabling
 <p>Symmetrical shielded (or armored) cable with three phase conductors and concentric PE conductor as shield (or armor)</p>	Yes	Yes
 <p>Symmetrical shielded (or armored) cable with three phase conductors and symmetrically constructed PE conductor and a shield (or armor)</p>	Yes	Yes
 <p>Symmetrical shielded (or armored) cable with three phase conductors and a shield (or armor), and separate PE conductor/cable¹⁾</p>	Yes	Yes

¹⁾ A separate PE conductor is required if the conductivity of the shield (or armor) is not sufficient for the PE use.

Alternate power cable types

Cable type	Use as input power cabling	Use as motor cabling and as brake resistor cabling
 <p>Four-conductor cable in plastic jacket (three phase conductors and PE)</p>	<p>Yes with phase conductor smaller than 10 mm² (8 AWG) Cu.</p>	<p>Yes with phase conductor smaller than 10 mm² (8 AWG) Cu, or motors up to 30 kW (40 hp). Note: Shielded or armored cable, or cabling in metal conduit is always recommended to minimize radio frequency interference.</p>
 <p>Four-conductor armored cable (three phase conductors and PE)</p>	<p>Yes</p>	<p>Yes with phase conductor smaller than 10 mm² (8 AWG) Cu, or motors up to 30 kW (40 hp)</p>
 <p>Shielded (Al/Cu shield or armor)¹⁾ four-conductor cable (three phase conductors and a PE)</p>	<p>Yes</p>	<p>Yes with motors up to 100 kW (135 hp). A potential equalization between the frames of motor and driven equipment is required.</p>

¹⁾ Armor may act as an EMC shield, as long as it provides the same performance as a concentric EMC shield of a shielded cable. To be effective at high frequencies, the shield conductivity must be at least 1/10 of the phase conductor conductivity. The effectiveness of the shield can be evaluated based on the shield inductance, which must be low and only slightly dependent on frequency. The requirements are easily met with a copper or aluminum shield/armor. The cross-section of a steel shield must be ample and the shield helix must have a low gradient. A galvanized steel shield has a better high-frequency conductivity than a non-galvanized steel shield.

Not allowed power cable types

Cable type	Use as input power cabling	Use as motor cabling and as brake resistor cabling
 <p>Symmetrical shielded cable with individual shields for each phase conductor</p>	No	No

■ Additional guidelines – North America

ABB recommends the use of metallic conduit for power wiring. ABB also recommends the use of symmetrical shielded VFD cable between drive and motor(s).

This table shows examples of methods for wiring the drive. Refer to NFPA 70 (NEC) along with state and local codes for the appropriate methods for your application.

Wiring method	Notes
Conduit - Metallic ^{1) 2)}	
Electrical metallic tubing: Type EMT	Prefer symmetrical shielded VFD cable. Use separate conduit run for each motor. Do not run input power wiring and motor wiring in the same conduit.
Rigid metal conduit: Type RMC	
Liquid-tight flexible metal electrical conduit: Type LFMC	
Conduit - Non-metallic ^{2) 3)}	
Liquid-tight flexible non-metallic conduit: Type LFNC	Prefer symmetrical shielded VFD cable. Use separate conduit run for each motor. Do not run input power wiring and motor wiring in the same conduit.
Wireways ²⁾	
Metallic	Prefer symmetrical shielded VFD cable. Separate motor wiring from input power wiring and other low voltage wiring. Do not run outputs of multiple drives parallel. Bundle each cable (wiring) together and use separators where possible.

Wiring method	Notes
Free air ²⁾	
Enclosures, air handlers, etc.	Prefer symmetrical shielded VFD cable. Allowed internally in enclosures when in accordance with UL.

1) Metallic conduit may be used as an additional ground path, provided this path is a solid path capable of handling ground currents.

2) See NFPA NFPA 70 (NEC), UL, and local codes for your application.

3) Non-metallic conduit use underground is allowed; however, these installations inherently have an increased chance for nuisance problems due to the potential for water/moisture in the conduit. Water/moisture in the conduit increases the likelihood of VFD faults or warnings. Proper installation is required to make sure there is no intrusion of water/moisture.

Metal conduit

Couple separate parts of a metal conduit together: bridge the joints with a ground conductor bonded to the conduit on each side of the joint. Also bond the conduits to the drive enclosure and motor frame. Use separate conduits for input power, motor, brake resistor, and control wiring. Do not run motor wiring from more than one drive in the same conduit.

■ Power cable shield

If the cable shield is used as the sole protective earth (PE) conductor, make sure that its conductivity agrees with the PE conductor requirements.

To effectively suppress radiated and conducted radio-frequency emissions, the cable shield conductivity must be at least 1/10 of the phase conductor conductivity. The requirements are easily met with a copper or aluminum shield. The minimum requirement of the motor cable shield of the drive is shown below. It consists of a concentric layer of copper wires with an open helix of copper tape or copper wire. The better and tighter the shield, the lower the emission level and bearing currents.

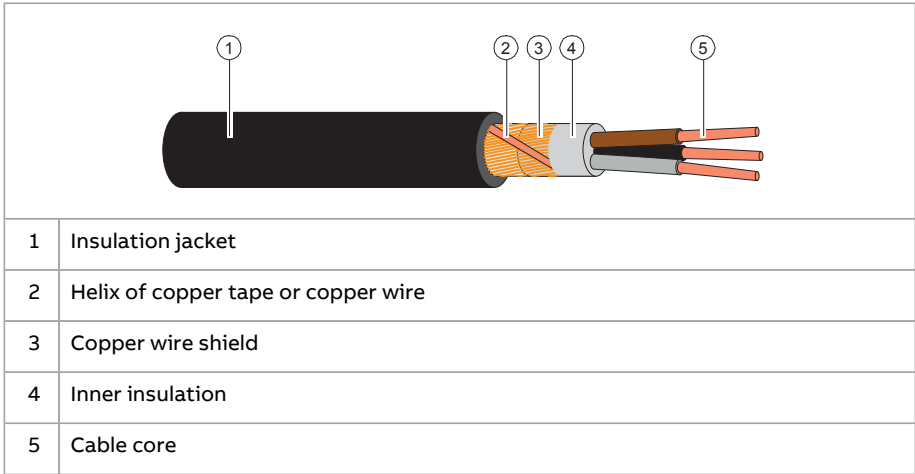

Grounding requirements

This section gives general requirements for grounding the drive. When you plan the grounding of the drive, obey all the applicable national and local regulations.

The conductivity of the protective earth conductor(s) must be sufficient.

Unless local wiring regulations state otherwise, the cross-sectional area of the protective earth conductor must agree with the conditions that require automatic disconnection of the supply required in 411.3.2 of IEC 60364-4-41:2005 and be capable of withstanding the prospective fault current during the disconnection time of the protective device. The cross-sectional area of the protective earth conductor must be selected from the table below or calculated according to 543.1 of IEC 60364-5-54.

The table shows the minimum cross-sectional area of the protective earth conductor related to the phase conductor size according to IEC/UL 61800-5-1 when the phase conductor(s) and the protective earth conductor are made of the same metal. If they are different metals, the cross-sectional area of the protective

earth conductor must be determined in a manner which produces a conductance equivalent to that which results from the application of this table.

Cross-sectional area of the phase conductors S (mm ²)	Minimum cross-sectional area of the corresponding protective earth conductor S_p (mm ²)
$S \leq 16$	S^1
$16 < S \leq 35$	16
$35 < S$	$S/2$

¹⁾ For the minimum conductor size in IEC installations, refer to [Additional grounding requirements – IEC](#).

If the protective earth conductor is not part of the input power cable or input power cable enclosure, the minimum permitted cross-sectional area is:

- 2.5 mm² if the conductor is mechanically protected,
or
- 4 mm² if the conductor is not mechanically protected. If the equipment is cord-connected, the protective earth conductor must be the last conductor to be interrupted if there is a failure in the strain relief mechanism.

■ Additional grounding requirements – IEC

This section gives grounding requirements according to standard IEC/EN 61800-5-1.

Because the normal touch current of the drive is more than 3.5 mA AC or 10 mA DC:

- the minimum size of the protective earth conductor must comply with the local safety regulations for high protective earth conductor current equipment, and
- you must use one of these connection methods:
 1. a fixed connection and:
 - a protective earth conductor with a minimum cross-sectional area of 10 mm² Cu or 16 mm² Al (as an alternative when aluminum cables are permitted),
or
 - a second protective earth conductor of the same cross-sectional area as the original protective earth conductor,
or
 - a device that automatically disconnects the supply if the protective earth conductor is damaged.
 2. a connection with an industrial connector according to IEC 60309 and a minimum protective earth conductor cross-section of 2.5 mm² as part of a multi-conductor power cable. Sufficient strain relief must be provided.

If the protective earth conductor is routed through a plug and socket, or similar means of disconnection, it must not be possible to disconnect it unless power is simultaneously removed.

Note: You can use power cable shields as protective earth conductors only when their conductivity is sufficient.

■ **Additional grounding requirements – UL (NEC)**

This section gives grounding requirements according to standard UL 61800-5-1.

The protective earth conductor must be sized as specified in Article 250.122 and table 250.122 of the National Electric Code, ANSI/NFPA 70.

For cord-connected equipment, it must not be possible to disconnect the protective earth conductor before power is removed.

Selecting the control cables

■ **Shielding**

Only use shielded control cables.

Use a double-shielded twisted pair cable for analog signals. ABB recommends this type of cable also for the pulse encoder signals. Use one individually shielded pair for each signal. Do not use common return for different analog signals.

A double-shielded cable (a) is the best alternative for low-voltage digital signals, but single-shielded (b) twisted pair cable is also acceptable.

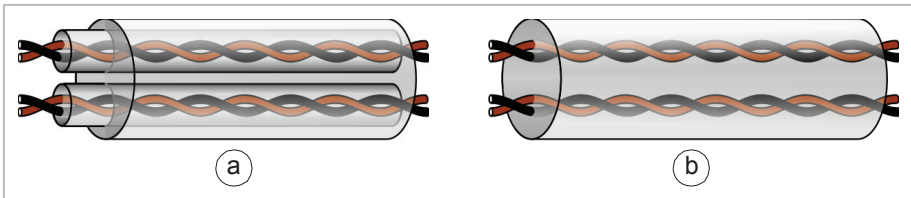

■ **Signals in separate cables**

Run analog and digital signals in separate, shielded cables. Do not mix 24 V DC and 115/230 V AC signals in the same cable.

■ **Signals that can be run in the same cable**

If their voltage does not exceed 48 V, relay-controlled signals can be run in the same cables as digital input signals. The relay-controlled signals should be run as twisted pairs.

■ Relay cable

The cable type with braided metallic shield (for example ÖLFLEX by LAPPKABEL, Germany) has been tested and approved by ABB.

■ Control panel to drive cable

Use EIA-485, Cat 5e (or better) cable with male RJ-45 connectors. The maximum length of the cable is 100 m (328 ft).

■ PC tool cable

Connect the Drive Composer PC tool to the drive through the USB port of the control panel. Use a USB Type A (PC) - Type Mini-B (control panel) cable. The maximum length of the cable is 3 m (9.8 ft).

Routing the cables

■ General guidelines – IEC

- Route the motor cable away from other cables. Motor cables of several drives can be run in parallel installed next to each other.
- Install the motor cable, input power cable and control cables on separate trays.
- Avoid long parallel runs of motor cables with other cables.
- Where control cables must cross power cables, make sure that they are arranged at an angle as near to 90 degrees as possible.
- Do not run extra cables through the drive.
- Make sure that the cable trays have good electrical bonding to each other and to the grounding electrodes. Aluminum tray systems can be used to improve local equalizing of potential.

The following figure illustrates the cable routing guidelines with an example drive.

Note: When motor cable is symmetrical and shielded and it has short parallel runs with other cables (< 1.5 m / 5 ft), distances between the motor cable and other cables can be reduced by half.

56 Guidelines for planning the electrical installation

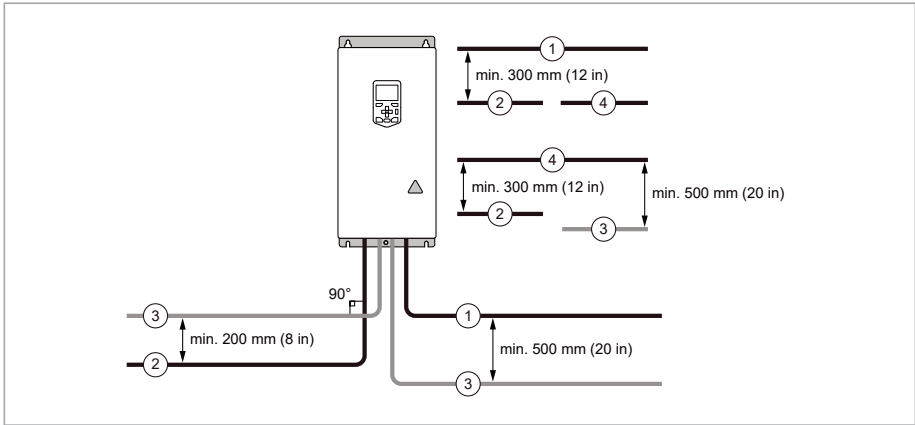

1	Motor cable
2	Input power cable
3	Control cable
4	Brake resistor or chopper cable (if any)

■ General guidelines – North America

Make sure that the installation is in accordance with national and local codes. Obey these general guidelines:

- Use separate conduits for the input power, motor, brake resistor (optional), and control cabling.
- Use separate conduit for each motor cabling.

The following figure illustrates the cable routing guidelines with an example drive.

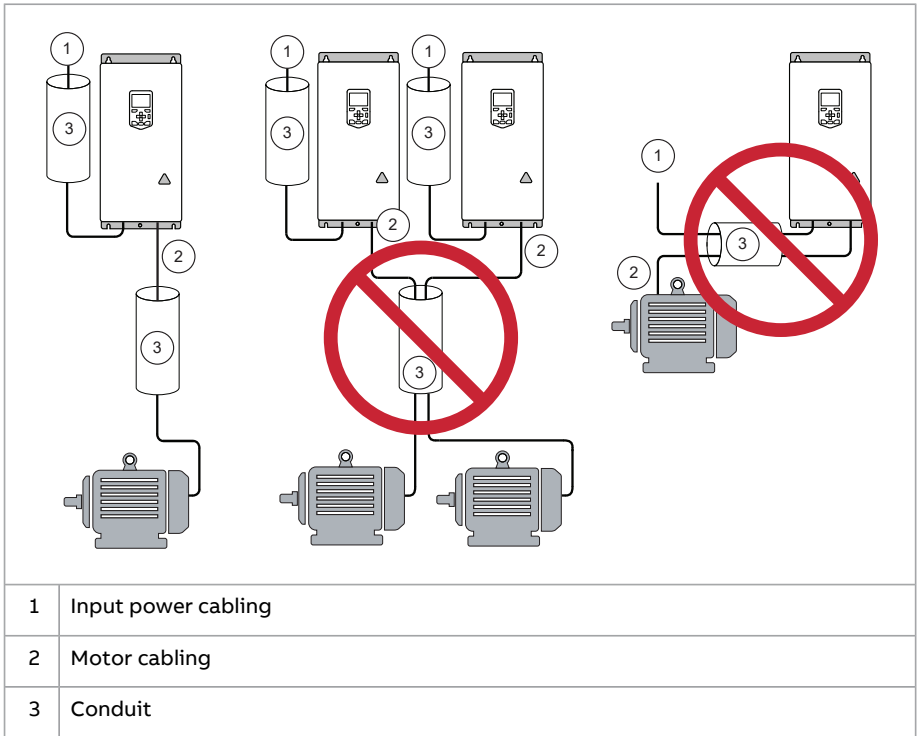

■ Continuous motor cable shield/conduit and metal enclosure for equipment on the motor cable

To minimize the emission level when safety switches, contactors, connection boxes or similar equipment are installed on the motor cable between the drive and the motor:

- Install the equipment in a metal enclosure.
- Use either a symmetrical shielded cable, or install the cabling in a metal conduit.
- Make sure that there is a good and continuous galvanic connection in the shield/conduit between drive and motor.
- Connect the shield/conduit to the protective ground terminal of the drive and the motor.

■ **Separate control cable ducts**

Put 24 V DC and 230 V AC (120 V AC) control cables in separate ducts, unless the 24 V DC cable is insulated for 230 V AC (120 V AC) or insulated with an insulation sleeving for 230 V AC (120 V AC).

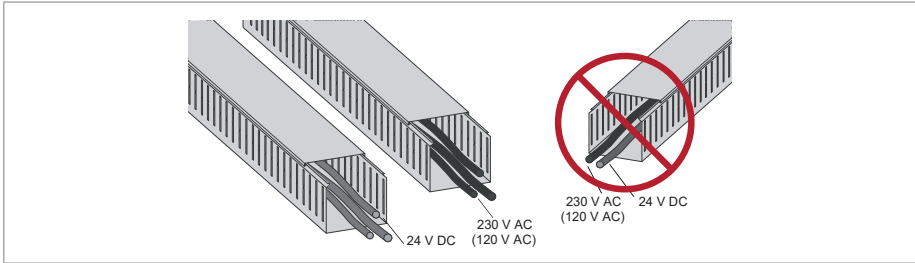

Implementing short-circuit and thermal overload protection

■ **Protecting the drive and input power cable in short-circuits**

Use the fuses specified for the drive in the technical data. Make sure that also the electric power supply network meets the specification (minimum allowed short-circuit current that the fuse selection is based on).

The fuses restrict drive damage and prevent damage to adjoining equipment in case of a short-circuit inside the drive. When located at the distribution board, the fuses also protect the input power cable against short circuits.

See the drive technical data for alternative short-circuit protections.

■ **Protecting the motor and motor cable in short-circuits**

The drive protects the motor cable and motor in a short-circuit situation when:

- the motor cable is sized correctly
- the motor cable type complies with the motor cable selection guidelines by ABB
- the cable length does not exceed the allowed maximum length specified for the drive
- the setting of parameter 99.10 Motor nominal power in the drive is equal with the value given on the motor rating plate.

The electronic power output short-circuit protection circuitry meets the requirements of IEC 60364-4-41 2005/AMD1.

■ Protecting the drive, and the input power and motor cables against thermal overload

If the cables have the correct size for the nominal current, the drive protects itself and the input and motor cables against thermal overload. No additional thermal protection devices are needed.



WARNING!

If the drive is connected to multiple motors, use a separate motor thermal overload device for protecting each motor cable and motor against overload. The drive overload protection is for the sum of the total motor load. It may not trip due to an overload in one motor.

■ Protecting the motor against thermal overload

According to regulations, the motor must be protected against thermal overload and the current must be switched off when overload is detected. The drive includes a motor thermal protection function that protects the motor and switches off the current when necessary. Depending on a drive parameter value, the function either monitors a calculated temperature value (based on a motor thermal model) or an actual temperature indication given by motor temperature sensors.

The motor thermal protection model supports thermal memory retention and speed sensitivity. The user can tune the thermal model further by feeding in additional motor and load data.

The most common temperature sensor types are PTC or Pt100.

For more information, see the firmware manual.

■ Protecting the motor against overload without thermal model or temperature sensors

Motor overload protection protects the motor against overload without using motor thermal model or temperature sensors.

Motor overload protection is required and specified by multiple standards including the US National Electric Code (NEC) and the common UL/IEC 61800-5-1 standard in conjunction with UL/IEC 60947-4-1. The standards allow for motor overload protection without external temperature sensors.

The protection feature of the drive allows the user to specify the class of operation in the same manner as the overload relays are specified in standards UL/IEC 60947-4-1 and NEMA ICS 2.

The motor overload protection supports thermal memory retention and speed sensitivity.

For more information, see drive firmware manual.

Implementing a motor temperature sensor connection



WARNING!

IEC 61800-5-1 requires double or reinforced insulation between live parts and accessible parts when:

- the accessible parts are not conductive, or
- the accessible parts are conductive, but not connected to the protective earth.

Obey this requirement when you plan the connection of the motor temperature sensor to the drive.

You have these implementation alternatives:

1. If there is double or reinforced insulation between the sensor and the live parts of the motor: You can connect the sensor directly to the analog/digital input(s) of the drive. See the control cable connection instructions. Make sure that the voltage is not more than the maximum allowed voltage over the sensor.
2. If there is basic insulation between the sensor and the live parts of the motor, or if the insulation type is not known: You can connect a sensor to a digital input of the drive via an external relay. The sensor and the relay must form a double or reinforced insulation between the motor's live parts and the digital input of the drive. Make sure that the voltage does not exceed the maximum allowed voltage over the sensor.

Protecting the drive against ground faults

The drive is equipped with an internal ground fault protective function to protect the unit against ground faults in the motor and motor cable. This function is not a personnel safety or a fire protection feature. See the firmware manual for more information.

■ Residual current device compatibility

The drive is suitable for use with residual current devices of Type B.

Note: As standard, the drive contains capacitors connected between the main circuit and the frame. These capacitors and long motor cables increase the ground leakage current and may cause nuisance faults in residual current devices.

Implementing the Emergency stop function

For safety reasons, install the emergency stop devices at each operator control station and at other operating stations where emergency stop may be needed. Design the emergency stop according to the applicable standards.

You can use the Safe torque off function of the drive to implement the Emergency stop function.

Note: Pressing the stop (off) key on the control panel of the drive does not generate an emergency stop of the motor or separate the drive from dangerous potential.

Implementing the Safe torque off function

See chapter [The Safe torque off function \(page 225\)](#).

Using a safety switch between the drive and the motor

ABB recommends to install a safety switch between the permanent magnet motor and the drive output. The switch is needed to isolate the motor from the drive during maintenance work on the drive.

Implementing the control of a contactor between drive and motor

Implementing the control of the output contactor depends on the motor control mode and stopping method selected.

When you select the vector motor control mode and the motor ramp stop mode, use this operation sequence to open the contactor:

1. Give a stop command to the drive.
2. Wait until the drive decelerates the motor to zero speed.
3. Open the contactor.



WARNING!

If vector motor control mode is in use, do not open the output contactor while the drive controls the motor. The motor control operates faster than the contactor, and tries to maintain the load current. This can cause damage to the contactor.

When you select the vector motor control mode and the motor coast stop mode, you can open the contactor immediately after the drive has received the stop command. This is the case also if you use the scalar motor control mode.

Protecting the contacts of relay outputs

Inductive loads (relays, contactors, motors) cause voltage transients when switched off.

It is highly recommended that inductive loads are equipped with noise attenuating circuits (varistors, RC filters [AC] or diodes [DC]) to minimize the EMC emission at switch-off. If not suppressed, the disturbances can connect capacitively or

62 Guidelines for planning the electrical installation

inductively to other conductors in the control cable and form a risk of malfunction in other parts of the system.

Install the protective component as close to the inductive load as possible. Do not install protective components at the relay outputs.

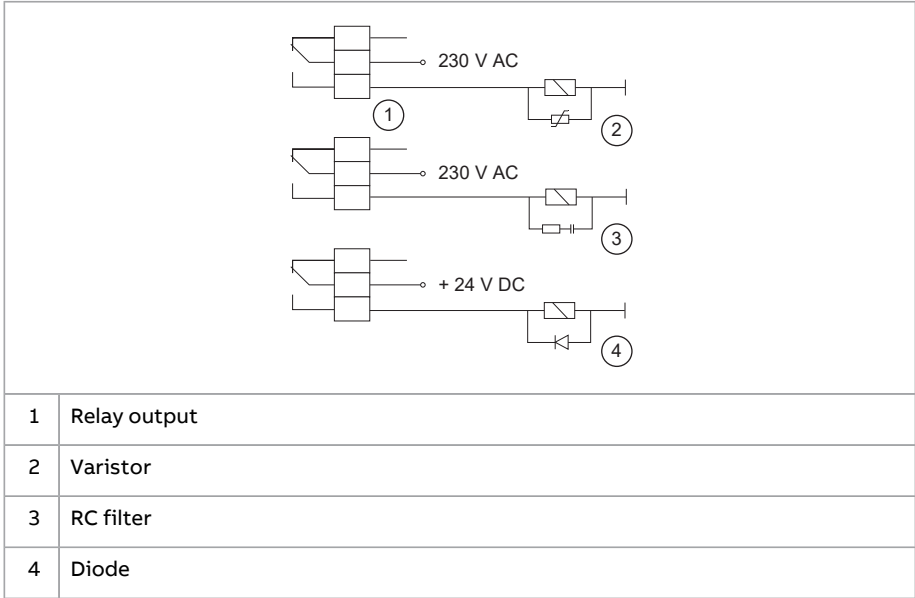

6

Electrical installation – IEC

Contents of this chapter

This chapter describes how to:

- measure the insulation
- do the grounding system compatibility check
- change the EMC filter or ground-to-phase varistor connection
- connect the power and control cables
- install optional modules
- connect a PC.

Required tools

To do the electrical installation, you need the following tools:

- wire stripper
- screwdriver or wrench with a set of suitable bits. For motor cable terminals, the recommended screwdriver shaft length is 150 mm (5.9 in).
- short flat head screwdriver for the I/O terminals
- torque wrench
- multimeter and voltage detector
- personal protective equipment.



Measuring the insulation resistance - IEC

■ Measuring the insulation resistance of the drive



WARNING!

Do not do voltage withstand or insulation resistance tests on the drive. The tests can cause damage to the drive. Every drive is tested for insulation between the main circuit and the chassis at the factory. Also, there are voltage-limiting circuits inside the drive which cut down the testing voltage automatically.

■ Measuring the insulation resistance of the input power cable

Before you connect the input power cable to the drive, measure its insulation resistance according to local regulations.

■ Measuring the insulation resistance of the motor and motor cable



WARNING!

Obey the safety instructions of the drive. If you ignore them, injury or death, or damage to the equipment can occur. If you are not a qualified electrical professional, do not do installation, commissioning or maintenance work.

1. Do the steps in section [Electrical safety precautions \(page 18\)](#) before you start the work.
2. Make sure that the motor cable is disconnected from the drive output terminals.
3. Measure the insulation resistance between each phase conductor and the protective earth conductor. Use a measuring voltage of 1000 V DC. The insulation resistance of an ABB motor must be more than 100 Mohm (reference value at 25 °C [77 °F]). For the insulation resistance of other motors, refer to the manufacturer's instructions.

Note: Moisture inside the motor reduces the insulation resistance. If you think that there is moisture in the motor, dry the motor and do the measurement again.

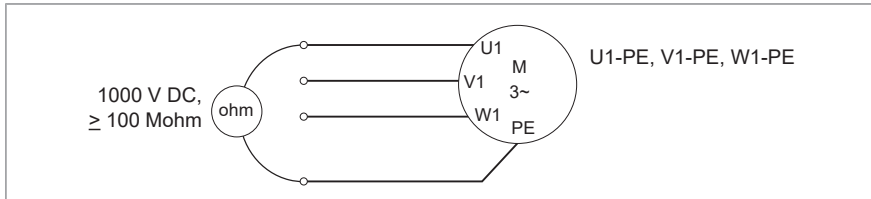

■ Measuring the insulation resistance of the brake resistor circuit



WARNING!

Obey the safety instructions of the drive. If you ignore them, injury or death, or damage to the equipment can occur. If you are not a qualified electrical professional, do not do installation, commissioning or maintenance work.

1. Stop the drive and do the steps in section [Electrical safety precautions \(page 18\)](#) before you start the work.
2. Make sure that the resistor cable is connected to the resistor and disconnected from the drive output terminals.
3. At the drive end, connect the R+ and R- conductors of the resistor cable together. Measure the insulation resistance between the conductors and the PE conductor with a measuring voltage of 1000 V DC. The insulation resistance must be more than 1 Mohm.

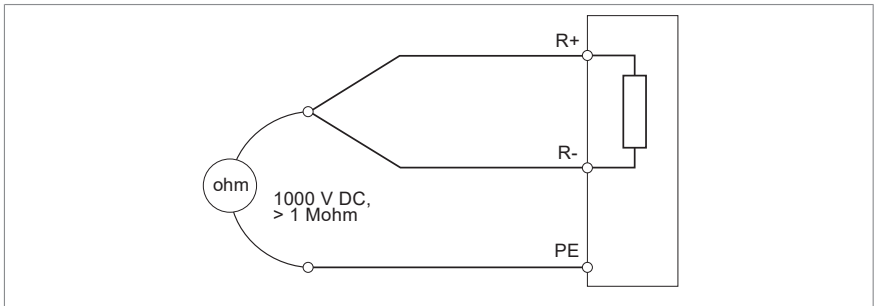

Grounding system compatibility check – IEC

This section is applicable to the IEC drive types.

■ EMC filter

The drive has an internal EMC filter as standard. You can install a drive that has the internal EMC filter connected to a symmetrically grounded TN-S system (center-grounded wye). For other systems, refer to [Compatibility of EMC filter and ground-to-phase varistor with the grounding system \(page 66\)](#).

Note: If you disconnect the EMC filter, the electromagnetic compatibility of the drive decreases.





WARNING!

Do not install a drive with the internal EMC filter connected to a grounding system that the EMC filter is not compatible with (for example, an IT system). The supply network becomes connected to ground potential through the internal EMC filter capacitors, which can cause danger or damage to the drive.

■ **Ground-to-phase varistor**

The drive has a ground-to-phase varistor circuit as standard. You can install a drive that has the varistor circuit connected to a symmetrically grounded TN-S system (center-grounded wye). For other systems, refer to [Compatibility of EMC filter and ground-to-phase varistor with the grounding system \(page 66\)](#). In some product variants, the varistor circuit is disconnected at the factory.



WARNING!

Do not install the drive with the ground-to-phase varistor connected to a system that the varistor is not suitable for. It can cause damage to the varistor circuit.

■ **Compatibility of EMC filter and ground-to-phase varistor with the grounding system**



WARNING!

If you do not obey these instructions, injury to personnel or damage to the drive can occur.

A metal EMC screw is used to connect the internal EMC filter, and a metal VAR screw is used to connect the ground-to-phase varistor. The screws are installed at the factory. The material of the screws (plastic or metal) depends on the product



variant. Before you connect the drive to the input power, examine the screws and do the necessary actions shown in the table.

Screw label	Screw material	When to remove EMC screw or VAR screw		
		Symmetrically grounded TN-S systems, i.e, center-grounded wye (A)	Corner-grounded delta (B1), mid-point-grounded delta (B2) and TT (D) systems	IT systems (un-grounded or high-resistance grounded) (C)
EMC	Metal	Do not remove	Remove	Remove
	Plastic	Do not remove ¹⁾	Do not remove	Do not remove
VAR	Metal	Do not remove	Do not remove	Remove
	Plastic	Do not remove	Do not remove	Do not remove

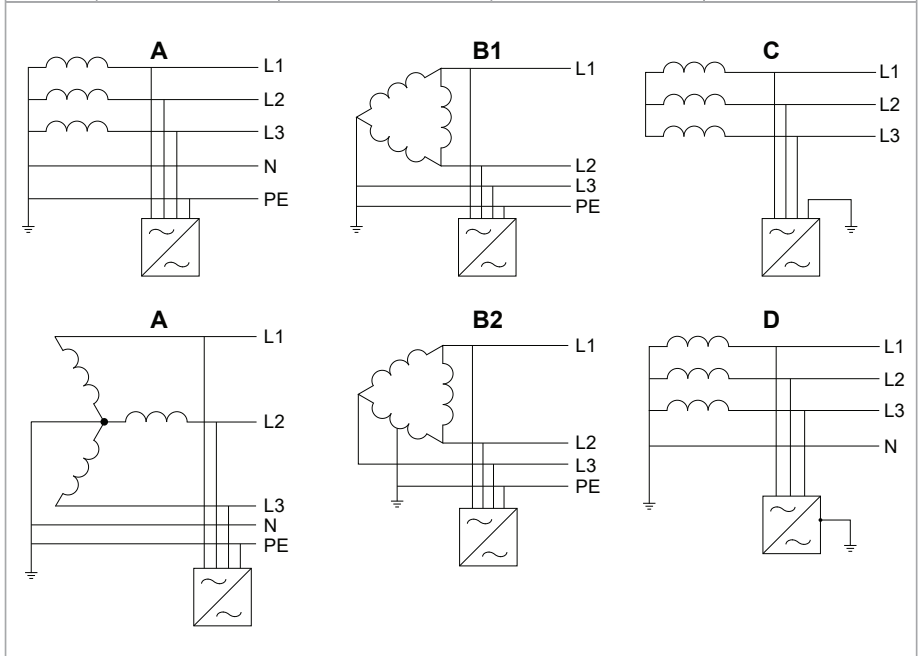

¹⁾ Can install the metal screw included in the drive delivery to connect the internal EMC filter.

For the locations of the screws, refer to [Disconnecting the EMC filter or ground-to-phase varistor \(page 68\)](#).



■ **Disconnecting the EMC filter or ground-to-phase varistor**

Before you continue, refer to [Compatibility of EMC filter and ground-to-phase varistor with the grounding system](#) (page 66).

- To disconnect the EMC filter, remove the metal EMC screw.
- To disconnect the ground-to-phase varistor, remove the metal VAR screw.

EMC/VAR screw location

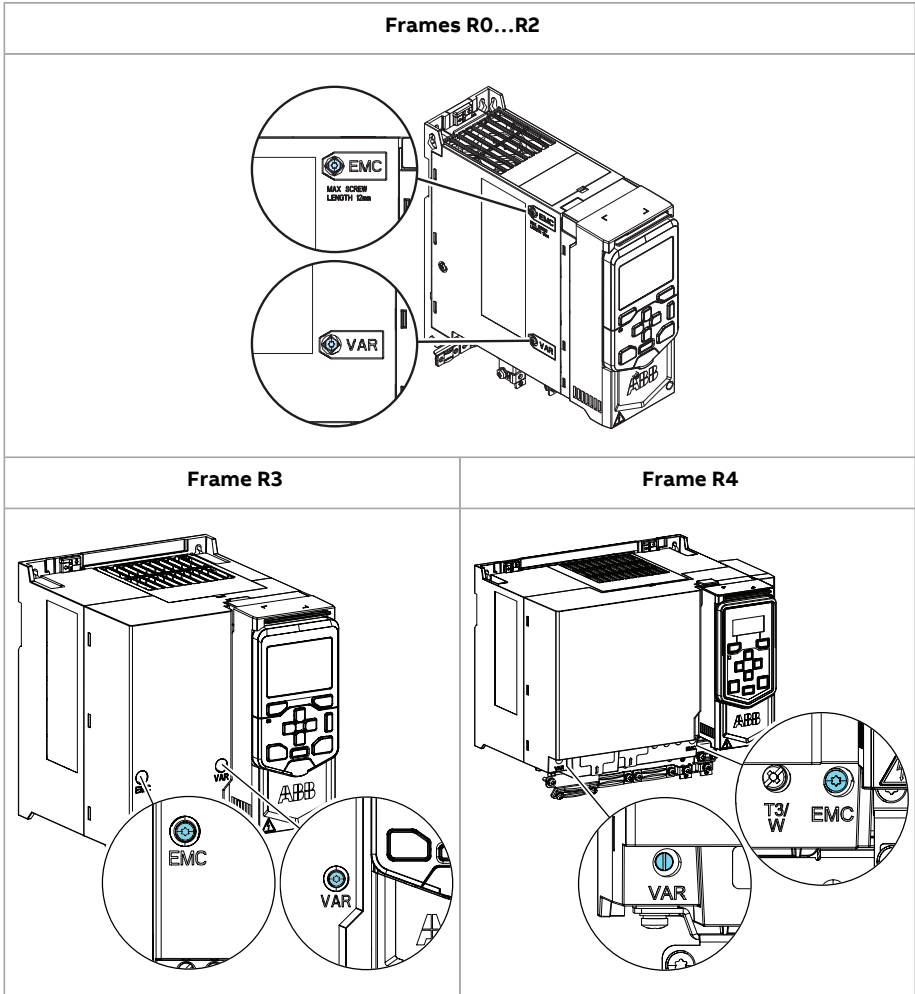

■ Guidelines for installing the drive to a TT system

You can install the drive to a TT system under these conditions:

1. There is a residual current device in the supply system
2. The internal EMC filter is disconnected. If the EMC filter is not disconnected, its leakage current will cause the residual current device to trip.

Note:

- ABB does not guarantee the EMC performance, because the internal EMC filter is disconnected.
- ABB does not guarantee the functioning of the ground leakage detector built inside the drive.
- In large systems the residual current device can trip without a real reason.

■ Identifying the grounding system of the electrical power network



WARNING!

Only a qualified electrical professional may do the work instructed in this section. Depending on the installation site, the work may even be categorized as live working. Continue only if you are an electrical professional certified for the work. Obey the local regulations. If you ignore them, injury or death can occur.

To identify the grounding system, examine the supply transformer connection. See the applicable electrical diagrams of the building. If that is not possible, measure these voltages at the distribution board, and use the table to define the grounding system type.

1. input voltage line to line (U_{L-L})
2. input voltage line 1 to ground (U_{L1-G})
3. input voltage line 2 to ground (U_{L2-G})
4. input voltage line 3 to ground (U_{L3-G}).



70 Electrical installation – IEC

The table below shows the line-to-ground voltages in relation to the line-to-line voltage for each grounding system.

U_{L-L}	U_{L1-G}	U_{L2-G}	U_{L3-G}	Electrical power system type
X	$0.58 \cdot X$	$0.58 \cdot X$	$0.58 \cdot X$	TN-S system (symmetrically grounded)
X	$1.0 \cdot X$	$1.0 \cdot X$	0	Corner-grounded delta system (nonsymmetrical)
X	$0.866 \cdot X$	$0.5 \cdot X$	$0.5 \cdot X$	Midpoint-grounded delta system (nonsymmetrical)
X	Varying level versus time	Varying level versus time	Varying level versus time	IT systems (ungrounded or high-resistance-grounded [>30 ohms]) nonsymmetrical
X	Varying level versus time	Varying level versus time	Varying level versus time	TT system (the protective earth connection for the consumer is provided by a local earth electrode, and there is another independently installed at the generator)



Connecting the power cables – IEC (shielded cables)

■ Connection diagram

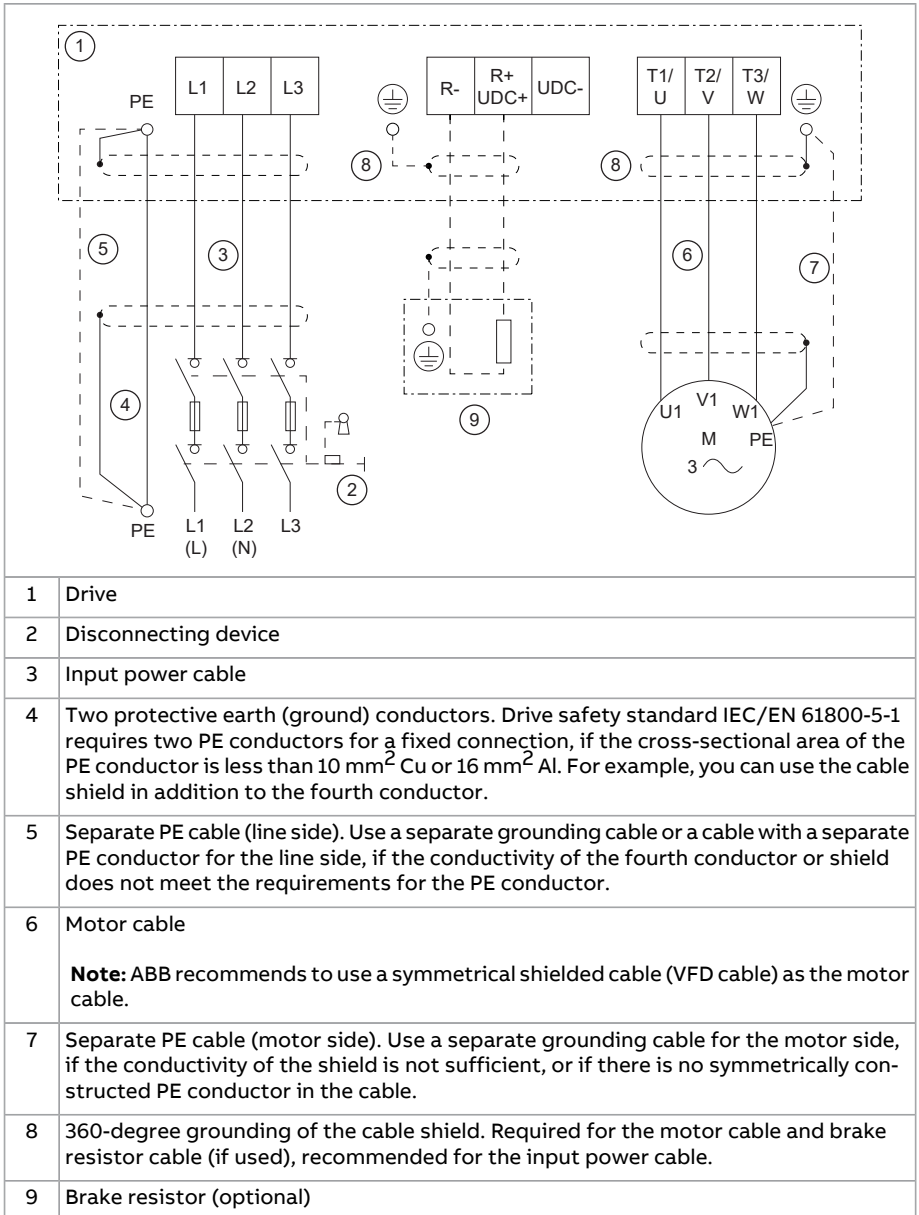

■ Connection procedure

 **WARNING!**
Obey the safety instructions of the drive. If you ignore them, injury or death, or damage to the equipment can occur. If you are not a qualified electrical professional, do not do installation, commissioning or maintenance work.

Refer to [Terminal data for the power cables \(page 163\)](#) for the tightening torques.

1. Do the steps in section [Electrical safety precautions \(page 18\)](#) before you start the work.
2. Remove the screw on the drive front cover and lift the front cover up.

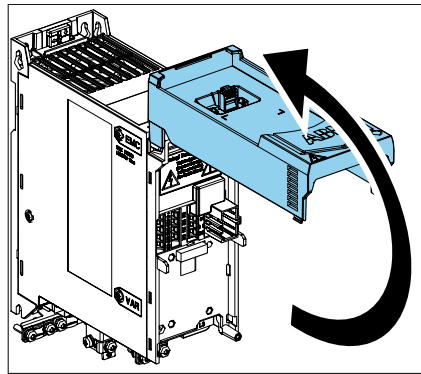
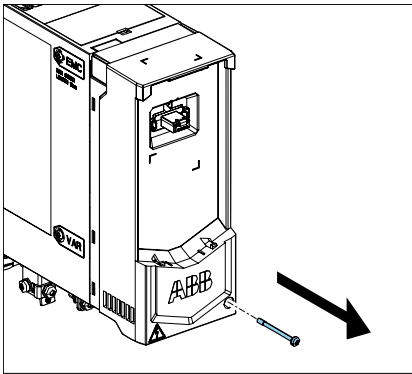

3. Attach the residual voltage warning sticker in the local language to the drive.
4. Strip the motor cable.
5. Ground the motor cable shield under the grounding clamp for 360-degree grounding.

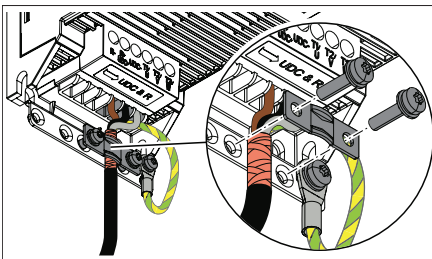

6. Twist the motor cable shield into a bundle, mark it with yellow-green insulation tape, install a cable lug, and connect it to the grounding terminal.

7. Connect the phase conductors of the motor cable to terminals T1/U, T2/V and T3/W.
8. If you use a brake resistor, connect the brake resistor cable to terminals R- and UDC+. Use shielded cable and ground the shield under the grounding clamp for 360-degree grounding.
9. Make sure that the R- and UDC+ terminal screws are tightened. Do this step also if you do not connect cables to the terminals.
10. Strip the input power cable.
11. If the input power cable has a shield, ground the shield under the clamp for 360-degree grounding. Twist the shield also into a bundle, mark it with yellow-green insulation tape, install a cable lug, and connect it to the grounding terminal.

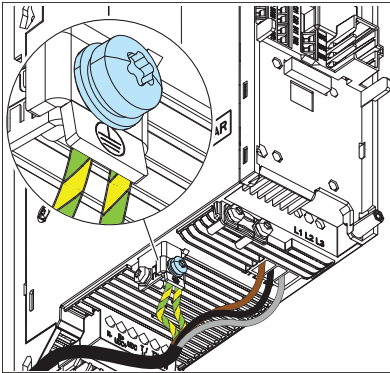

12. Connect the protective earth (ground) conductor(s) of the input power cable to the grounding terminal.
13. Connect the phase conductors of the input power cable to the drive as follows:
 - 1-phase drives: connect the phase and neutral conductors to terminals L1 and L2. For example, connect phase to L1 and neutral to L2.
 - 3-phase drives: connect the phase conductors to terminals L1, L2, and L3.
14. Mechanically attach all of the cables on the outside of the drive.



Connecting the control cables - IEC

Before you connect the control cables, make sure that all option modules are installed.

■ Default I/O connection diagrams (ABB standard macro)

The connection diagrams below are applicable to the standard drive variant with the RIIO-01 I/O & EIA-485 module. ABB standard macro (parameter 96.04) is used with the default parameter settings.

Connection	Terminal ¹⁾	Description	2)	
Analog inputs and outputs				
	1	SCR	Signal cable shield (screen)	
	2	AI1	Output frequency: 0 ... 10 V	
	3	AGND	Analog input circuit common	
	4	+10V	Reference voltage 10 V DC	
	5	AI2	Not configured	
	6	AGND	Analog input circuit common	
	7	AO1	Output frequency: 0 ... 20 mA	
	8	AO2	Motor current: 0 ... 20 mA	
	9	AGND	Analog output circuit common	
Digital inputs and auxiliary voltage output				
	10	+24V	Aux. voltage output +24 V DC, max. 250 mA ³⁾	×
	11	DGND	Aux. voltage output common	×
	12	DCOM	Digital input common for all	×
	13	DI1	Stop (0) / Start (1)	×
	14	DI2	Forward (0) / Reverse (1)	×
	15	DI3	Constant output frequency selection⁴⁾	
	16	DI4	Constant output frequency selection	
	17	DI5	Ramp set 1 (0) / Ramp set 2 (1)⁵⁾	
	18	DI6	Not configured	

Connection	Terminal ¹⁾	Description	2)		
Relay outputs					
	10	+24V	Aux. voltage output +24 V DC, max. 250 mA ³⁾		
	11	DGND	Aux. voltage output common		
	12	DCOM	Digital input common for all		
	19	RO1C	Common	Ready run 250 V AC / 30 V DC, 2 A	×
	20	RO1A	Norm. closed		×
	21	RO1B	Norm. open		×
	22	RO2C	Common	Running 250 V AC / 30 V DC, 2 A	
	23	RO2A	Norm. closed		
	24	RO2B	Norm. open		
	25	RO3C	Common	Fault (-1) 250 V AC / 30 V DC, 2 A	
	26	RO3A	Norm. closed		
	27	RO3B	Norm. open		
	Embedded EIA-485				
	29	B+	Embedded fieldbus (EIA-485)		
	30	A-			
	31	DGND			
S100	TERM	Termination switch. ON = on. 1 = off.			
Safe torque off					
	34	SGND	Safe torque off. Factory connection. Both circuits must be closed for the drive to start.	×	
	35	IN1		×	
	36	IN2		×	
	37	OUT1		×	
Auxiliary voltage input/output					
	42	+24V	Aux. voltage output +24 V DC, max. 250 mA ³⁾		
	43	DGND	Aux. voltage output common		
	44	DCOM	Digital input common for all		

1) Terminal size: 0.14 ... 1.5 mm² (26 ... 16 AWG) Tightening torque: 0.5 ... 0.6 N·m (4.4 ... 5.3 lbf·in)

2) × = base unit, empty = RIIO-01 module

3) The sum output current from 24 V terminals of base unit and RIIO-01 module must not exceed 250 mA.

4) Drive output frequency:

D13	D14	Operation/Parameter
0	0	Set output frequency through AI1
1	0	28.26 Constant frequency 1
0	1	28.27 Constant frequency 2
1	1	28.28 Constant frequency 3

5) See parameters 28.72, 28.73, 28.74 and 28.75.

■ Default fieldbus connection diagram

The connection diagrams are applicable to the base unit with an optional fieldbus adapter module. ABB standard macro (parameter 96.04) is used with its default parameter settings.

Connection	Terminal ¹⁾	Description	2)		
Auxiliary voltage output and digital inputs					
	10	+24V	Aux. voltage output +24 V DC, max. 250 mA	×	
	11	DGND	Aux. voltage output common	×	
	12	DCOM	Digital input common for all	×	
	13	DI1	Stop (0) / Start (1)	×	
	14	DI2	Forward (0) / Reverse (1)	×	
Relay outputs					
	10	+24V	Aux. voltage output +24 V DC, max. 250 mA	×	
	11	DGND	Aux. voltage output common	×	
	12	DCOM	Digital input common for all	×	
	19	RO1C	Common	Ready run 250 V AC / 30 V DC, 2 A	×
	20	RO1A	Norm. closed		×
21	RO1B	Norm. open	×		
Safe torque off					
	34	SGND	Safe torque off. Factory connection. Both circuits must be closed for the drive to start.	×	
	35	IN1		×	
	36	IN2		×	
	37	OUT1		×	

Connection	Terminal ¹⁾	Description	2)
Fieldbus connection			
See the applicable fieldbus adapter manual.	DSUB9	+K457 FCAN-01 CANopen	
	DSUB9	+K454 FPBA-01 Profibus DP	
	RJ45×2	+K469 FECA-01 EtherCAT	
	RJ45×2	+K475 FENA-21 Ethernet/IP, Profinet, Modbus TCP	
	RJ45×2	+K470 FEPL-02 Ethernet Powerlink	
	Terminal block	+K451 FDNA-01 DeviceNet	
	8P8C×2	+K462 FCNA-01 ControlNet	
	RJ45×2	+K490 FEIP-21 Two-port Modbus/IP adapter	
	RJ45×2	+K491 FMBT-21 Two-port Modbus/TCP adapter	
	RJ45×2	+K492 FPNO-21 Two-port Profinet IO adapter	

1) Terminal size: 0.14 ... 1.5 mm² (26 ... 16 AWG) Tightening torque: 0.5 ... 0.6 N·m (4.4 ... 5.3 lbf·in)

2) x = base unit, empty = fieldbus module

■ Control cable connection procedure

Do the connections according to the control macro (parameter 96.04) used.

Keep the signal wire pairs twisted as near to the terminals as possible to prevent inductive coupling.



WARNING!

Obey the safety instructions of the drive. If you ignore them, injury or death, or damage to the equipment can occur. If you are not a qualified electrical professional, do not do installation, commissioning or maintenance work.

1. Do the steps in section [Electrical safety precautions \(page 18\)](#) before you start the work.
2. Remove the screw on the drive front cover and lift the front cover up.
3. Strip a part of the outer shield of the control cable for grounding.
4. Use a cable tie to ground the outer shield to the grounding tab. For 360° grounding, use metallic cable ties.
5. Strip the control cable conductors.
6. Connect the conductors to the correct control terminals. Torque the terminal connections to 0.5 ... 0.6 N·m (4.4 ... 5.3 lbf·in).

7. Connect the shields and grounding wires to the SCR terminal. Torque the terminal connection to 0.5 ... 0.6 N·m (4.4 ... 5.3 lbf·in).
8. Mechanically attach the control cables on the outside of the drive.

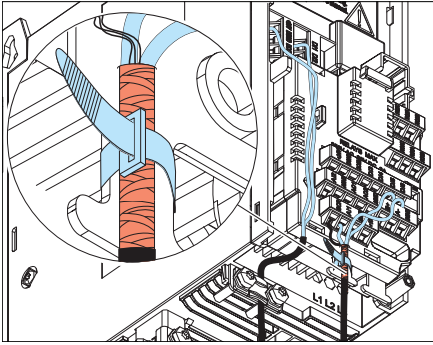

■ Additional information on the control connections

Embedded EIA-485 fieldbus connection

The EIA-485 network uses shielded, twisted-pair cable with a characteristic impedance of 100...130 ohm for data signaling. The distributed capacitance between conductors is less than 100 pF per meter (30 pF per foot). Distributed capacitance between conductors and shield is less than 200 pF per meter (60 pF per foot). Foil or braided shields are acceptable.

Connect the cable to the EIA-485 terminal on the RIIO-01 I/O module. Obey these wiring instructions:

- Attach the cable shields together at each drive, but do not connect them to the drive.
- Connect the cable shields only to the grounding terminal in the automation controller.
- Connect the signal ground (DGND) conductor to the signal ground reference terminal in the automation controller. If the automation controller does not have a signal ground reference terminal, connect the signal ground conductor to the cable shield through a 100 ohm resistor, preferably near the automation controller.



Connection examples are shown below.

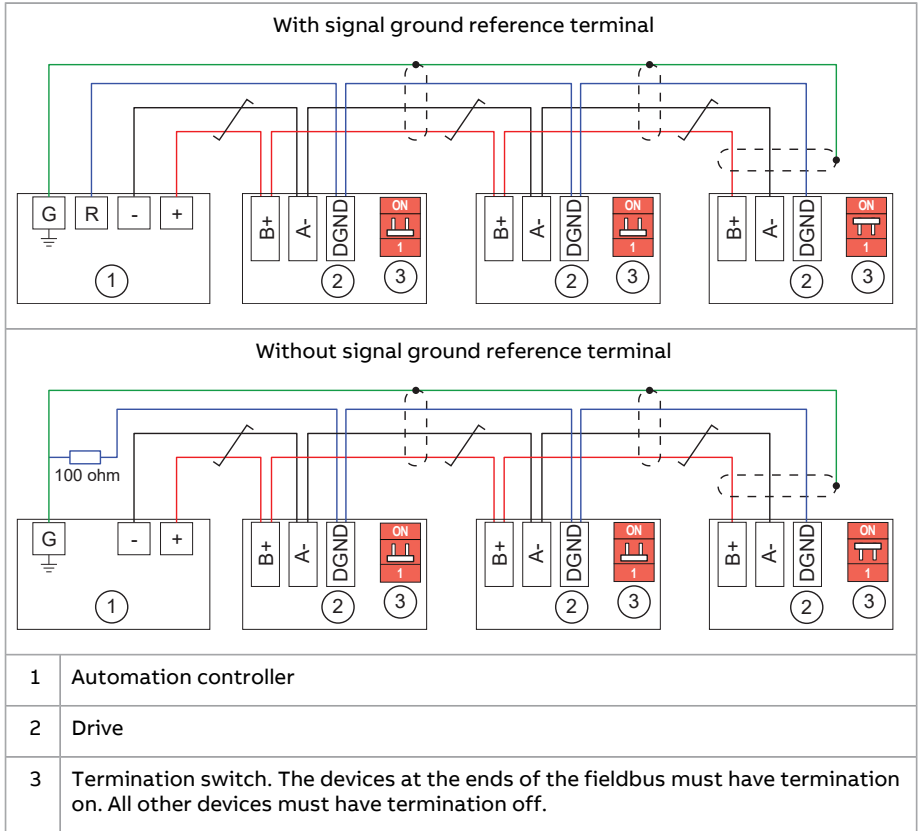

PNP configuration for digital inputs

Internal and external +24 V power supply connections for PNP (source) configuration are shown in the figures below.

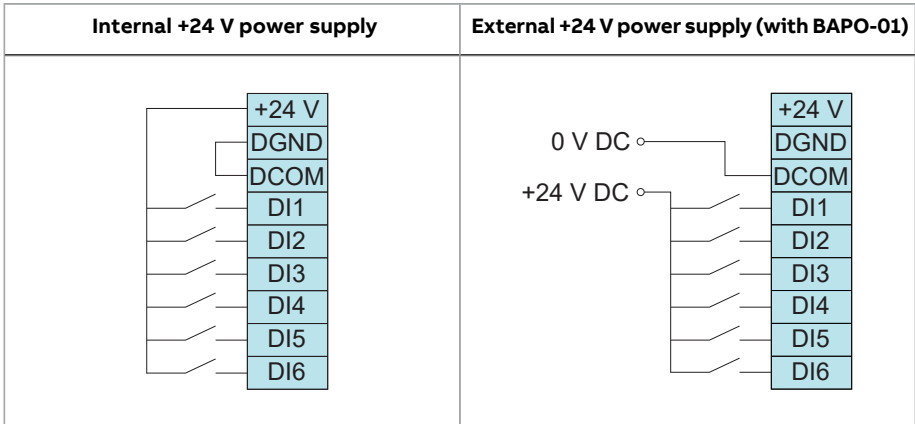

NPN configuration for digital inputs

Internal and external +24 V power supply connections for NPN (sink) configuration are shown in the figures below.

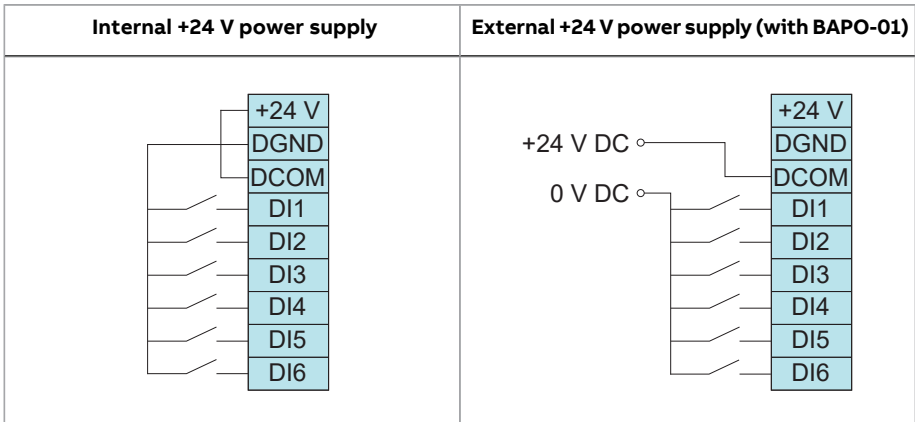

Connection for obtaining 0 ... 10 V from analog output 2 (AO2)

To obtain 0 ... 10 V from analog output AO2, connect a 500 ohm resistor (or two 1 kohm resistors in parallel) between AO2 and AGND. Examples are shown in the figure below.

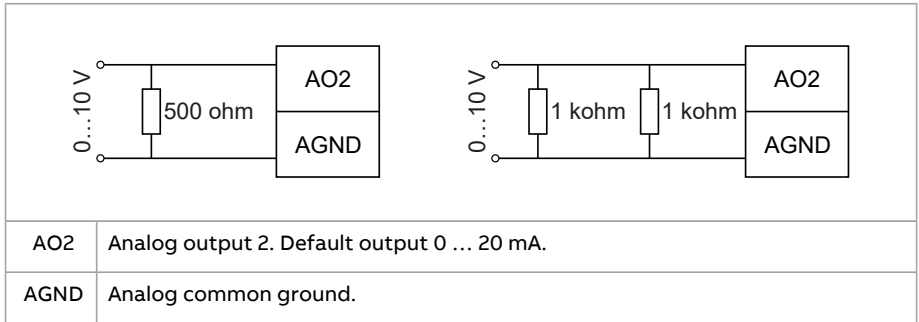

Connection examples of two-wire and three-wire sensors

The figures give examples of connections for a two-wire or three-wire sensor/transmitter that is supplied by the auxiliary voltage output of the drive.

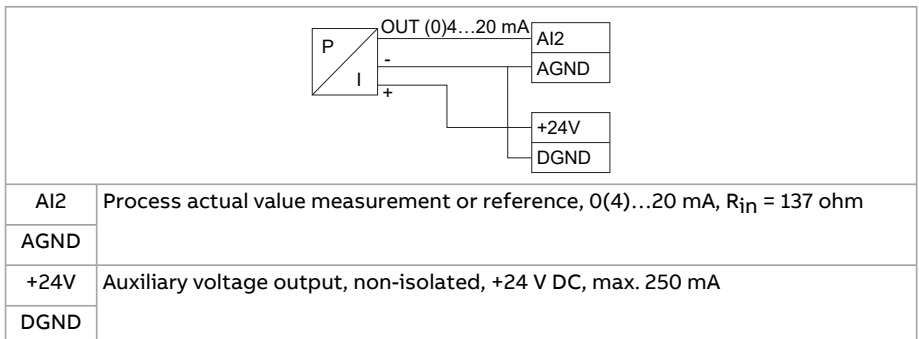
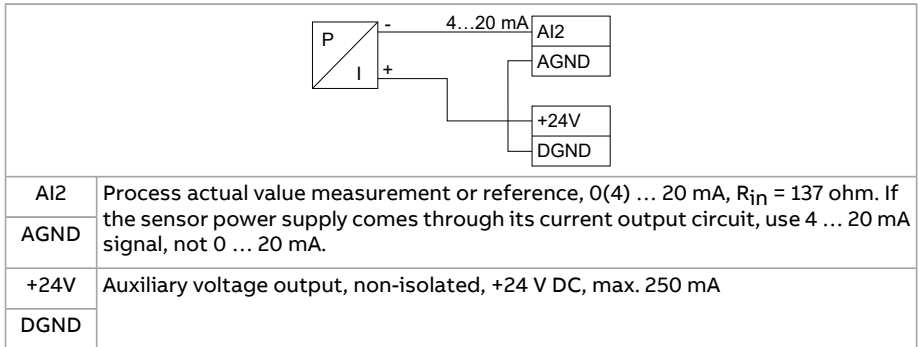

AI and AO (or AI, DI and +10 V) as PTC motor temperature sensor interface



WARNING!

IEC 61800-5-1 requires double or reinforced insulation between live parts and accessible parts when:

- the accessible parts are not conductive, or
- the accessible parts are conductive, but not connected to the protective earth.

Obey this requirement when you plan the connection of the motor temperature sensor to the drive.

To comply with the drive safety standard IEC 61800-5-1:

If the motor temperature sensor has double or reinforced insulation vs. the motor windings, you can connect it directly to the drive IO interface. This section shows two connection alternatives for the direct I/O connection. If the sensor does not have reinforced insulation, you must use another type of connection to comply with the safety standard. See [Implementing a motor temperature sensor connection \(page 60\)](#).

See the firmware manual for information on the related Motor thermal protection function, and the required parameter settings.

PTC connection 1

1...3 PTC sensors can be connected in series to an analog input and an analog output. Make sure that the voltage does not exceed the maximum allowed voltage over the sensor. The analog output feeds a constant excitation current of 1.6 mA through the sensor. The sensor resistance increases as the motor temperature rises, as does the voltage over the sensor. The temperature measurement function calculates the resistance of the sensor and generates an indication if overtemperature is detected. Leave the sensor end of the cable shield unconnected.



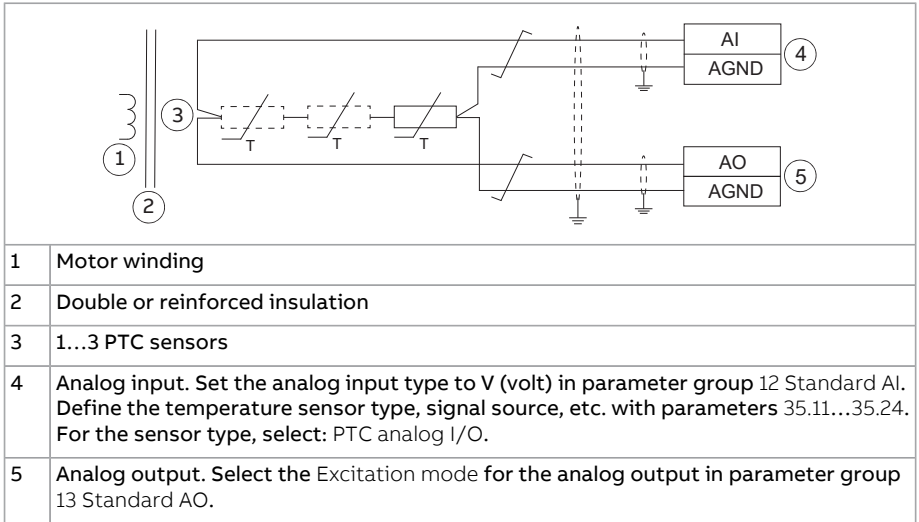

PTC connection 2

If no analog output is available for the PTC connection, it is possible to use a voltage divider connection. Make sure that the voltage does not exceed the maximum allowed voltage over the sensor. 1...3 PTC sensors are connected in series with 10 V reference and digital and analog inputs. The voltage over the digital input internal resistance varies depending on the PTC resistance. The temperature measurement function reads the digital input voltage through the analog input and calculates the PTC resistance.



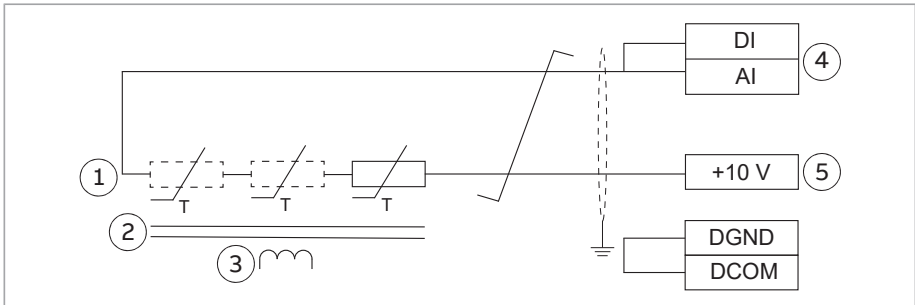

1	1...3 PTC sensors
2	Double or reinforced insulation
3	Motor winding
4	Digital input and analog input. Set the analog input type to V (volt) in parameter group 12 Standard AI. Define the temperature sensor type, signal source, etc. with parameters 35.11...35.24. For the sensor type, select: PTC AI/DI Voltage Divider tree. Make sure that the digital input is not configured to any other use by parameters.
5	10 V reference voltage

AI1 and AI2 as Pt100, Pt1000, Ni1000, KTY83 and KTY84 sensor inputs



WARNING!

IEC 61800-5-1 requires double or reinforced insulation between live parts and accessible parts when:

- the accessible parts are not conductive, or
- the accessible parts are conductive, but not connected to the protective earth.

Obey this requirement when you plan the connection of the motor temperature sensor to the drive.

To comply with the drive safety standard IEC 61800-5-1:

If the motor temperature sensor has double or reinforced insulation vs. the motor windings, you can connect it directly to the drive IO interface. This section shows the connection. If the sensor has no reinforced insulation, you must use another type of connection to comply with the safety standard. See [Implementing a motor temperature sensor connection \(page 60\)](#).

You can connect temperature measurement sensors (one, two or three Pt100 sensors; one, two or three Pt1000 sensors; or one Ni1000, KTY83 or KTY84) between an analog input and output as shown below. Make sure that the voltage does not exceed the maximum allowed voltage over the sensor. Leave the sensor end of the cable shield unconnected.

See the firmware manual for information on the related Motor thermal protection function.

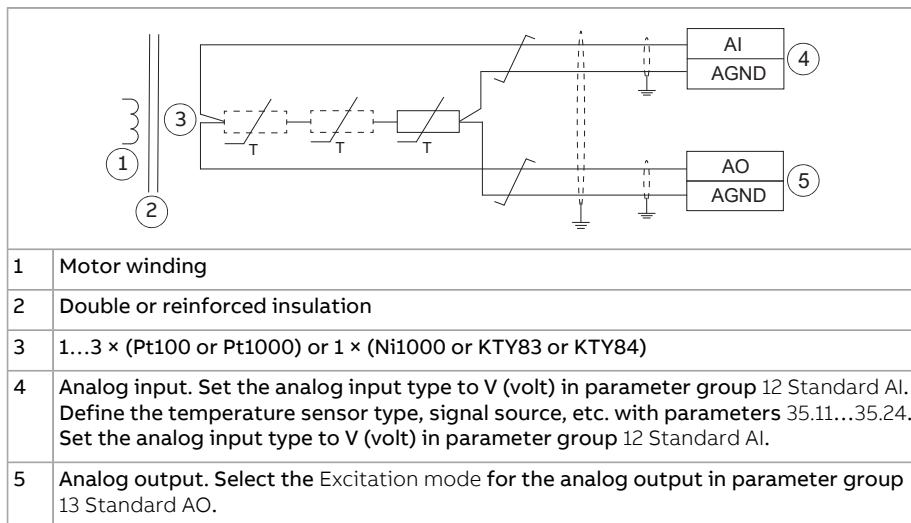

Safe torque off

For the drive to start, both STO connections (OUT1-IN1 and OUT1-IN2) must be closed. By default, the terminal block has jumpers to close the circuit. Remove the jumpers before connecting external Safe torque off circuitry to the drive. See chapter [The Safe torque off function](#).

Auxiliary voltage connection

The drive has 24 V DC ($\pm 10\%$) auxiliary power supply terminals both on the base unit and on the RIIO-01 module. You can use them:

- to supply auxiliary power from the drive to external control circuits or option modules
- to supply external auxiliary power to the drive to keep the control and cooling in operation if there is a power outage.

See the technical data for the specifications for the auxiliary power supply terminals (input/output).

To supply power to external control circuits or option modules:

1. Connect the load either to the auxiliary power output on the base unit, or on the RIIO-01 module (+24V and DGND terminals).
2. Make sure that you do not exceed the load capacity of the output, or the sum load capacity of both outputs.

To connect an external auxiliary power supply to the drive:

1. Install a BAPO-01 power extension module to the drive. See [Installing options \(page 86\)](#).
2. Connect an external power supply to the +24V and DGND terminals of the base unit.

For more information on the BAPO-01 module, see [BAPO-01 auxiliary power extension module \(page 245\)](#).

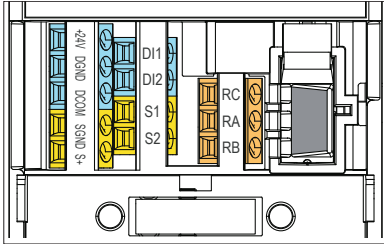

Connecting a PC

You can connect a PC to the drive. To communicate with the drive, the PC must have suitable software (for example, Drive composer) installed.

If you have an assistant control panel (ACS-AP-...), use a USB data cable (Type A - Type Mini-B, maximum length 3 m [9.8 ft]) to connect to the PC. Connect the cable as follows:

1. Open the USB connector cover on the control panel.
2. Connect the USB cable Mini-B plug to the control panel USB connector.
3. Connect the USB cable A plug to the USB port of the PC. The panel shows text "USB connected".

Note: You cannot use the control panel keys when the drive is connected to a PC.

If you have a RDUM-01 blank panel or CDPI-02 panel bus adapter installed, use a BCBL-01 USB-RJ45 converter to connect to the PC.

It is also possible to use a CCA-01 configuration adapter when the drive is not connected to the power supply network or to an external 24 V supply. The CCA-01 does not operate if the drive is powered.

Installing options

The drive has two option module slots:

- Front option: Communication module slot under the front cover.

- Side option: Multifunction extension module slot on the side of the drive.

Refer also to the applicable fieldbus module manual for the installation instructions. For other option modules, refer to:

- [BREL-01 relay output extension module \(page 255\)](#)
- [BAPO-01 auxiliary power extension module \(page 245\)](#)
- [BIO-01 I/O extension module \(page 249\)](#).

■ Installing a front option



WARNING!

Obey the safety instructions of the drive. If you ignore them, injury or death, or damage to the equipment can occur. If you are not a qualified electrical professional, do not do installation, commissioning or maintenance work.

1. Do the steps in section [Electrical safety precautions \(page 18\)](#) before you start the work.
2. Remove the screw on the drive front cover and lift the front cover up.
3. If the option module has a locking tab, pull it up.
4. Carefully align the option module with the option module slot and push it into position.
5. Torque the screw to 0.5 N·m (4.4 lbf·in).
6. If the option module has a locking tab, push it down until it locks.
7. Connect the control cables. See the control cable connection instructions.

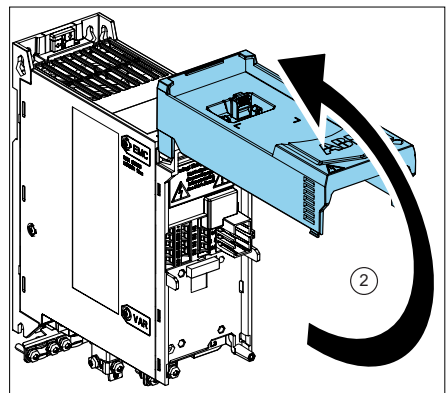
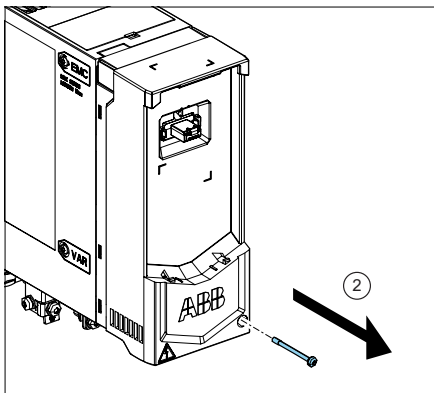

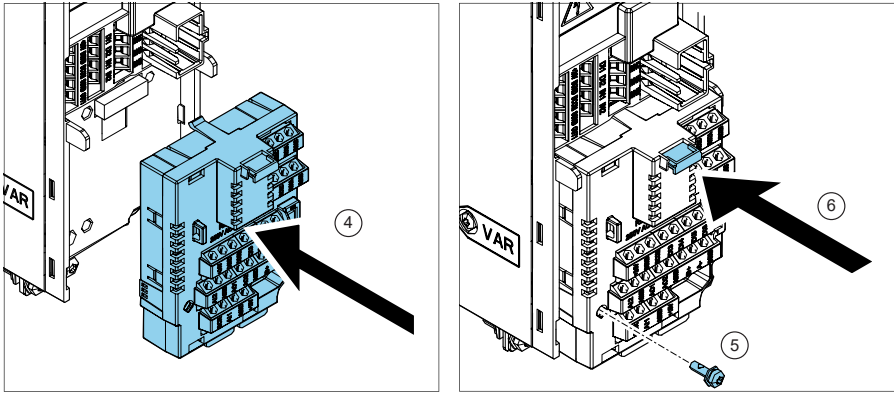

Note: If you have the BIO-01 option module, you can add one additional fieldbus module on top of it.

■ Installing a side option

⚠ WARNING! Obey the safety instructions of the drive. If you ignore them, injury or death, or damage to the equipment can occur. If you are not a qualified electrical professional, do not do installation, commissioning or maintenance work.

1. Do the steps in section [Electrical safety precautions \(page 18\)](#) before you start the work.
2. Remove the two screws from the front-most grounding clamp at the bottom of the drive.
3. Carefully align the side option with the connectors on the right side of the drive.
4. Fully push the option module into position.
5. Torque the screw on the option module to 1 N·m (8.8 lbf·in).



6. Attach the grounding bar to the bottom of the side option and to the front ground tab on the drive. Torque the screws to 1 N·m (8.8 lbf·in).
7. Connect the control cables. See the control cable connection instructions.

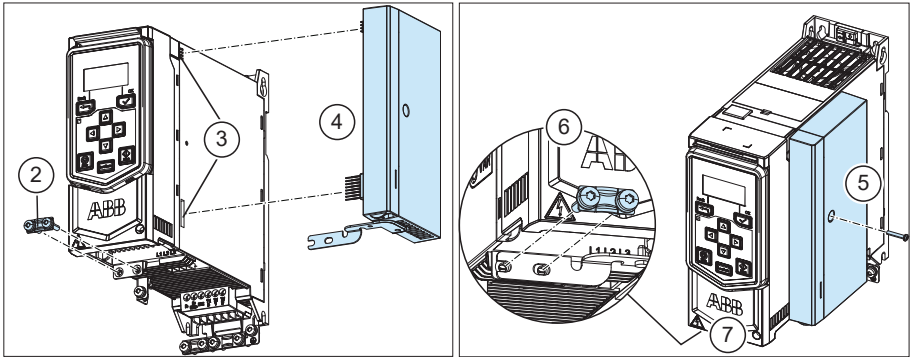

7

Electrical installation – North America

Contents of this chapter

This chapter describes how to:

- measure the insulation
- do the grounding system compatibility check
- change the EMC filter or ground-to-phase varistor connection
- connect the power and control cables
- install optional modules
- connect a PC.

Required tools

To do the electrical installation, you need the following tools:

- wire stripper
- screwdriver or wrench with a set of suitable bits. For motor cable terminals, the recommended screwdriver shaft length is 150 mm (5.9 in).
- short flat head screwdriver for the I/O terminals
- torque wrench
- multimeter and voltage detector



- personal protective equipment.

Measuring the insulation resistance - North America

■ Measuring the insulation resistance of the drive



WARNING!

Do not do voltage withstand or insulation resistance tests on the drive. The tests can cause damage to the drive. Every drive is tested for insulation between the main circuit and the chassis at the factory. Also, there are voltage-limiting circuits inside the drive which cut down the testing voltage automatically.

■ Measuring the insulation resistance of the input power cable

Before you connect the input power cable to the drive, measure its insulation resistance according to local regulations.

■ Measuring the insulation resistance of the motor and motor cable



WARNING!

Obey the safety instructions of the drive. If you ignore them, injury or death, or damage to the equipment can occur. If you are not a qualified electrical professional, do not do installation, commissioning or maintenance work.

1. Do the steps in section [Electrical safety precautions \(page 18\)](#) before you start the work.
2. Make sure that the motor cable is disconnected from the drive output terminals.
3. Measure the insulation resistance between each phase conductor and the protective earth conductor. Use a measuring voltage of 1000 V DC. The insulation resistance of an ABB motor must be more than 100 Mohm (reference value at 25 °C [77 °F]). For the insulation resistance of other motors, refer to the manufacturer's instructions.

Note: Moisture inside the motor reduces the insulation resistance. If you think that there is moisture in the motor, dry the motor and do the measurement again.

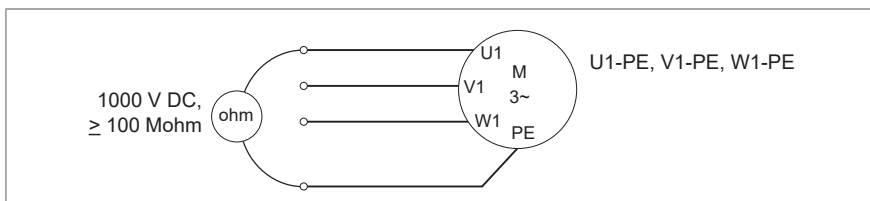

■ Measuring the insulation resistance of the brake resistor circuit



WARNING!

Obey the safety instructions of the drive. If you ignore them, injury or death, or damage to the equipment can occur. If you are not a qualified electrical professional, do not do installation, commissioning or maintenance work.

1. Stop the drive and do the steps in section [Electrical safety precautions \(page 18\)](#) before you start the work.
2. Make sure that the resistor cable is connected to the resistor and disconnected from the drive output terminals.
3. At the drive end, connect the R+ and R- conductors of the resistor cable together. Measure the insulation resistance between the conductors and the PE conductor with a measuring voltage of 1000 V DC. The insulation resistance must be more than 1 Mohm.

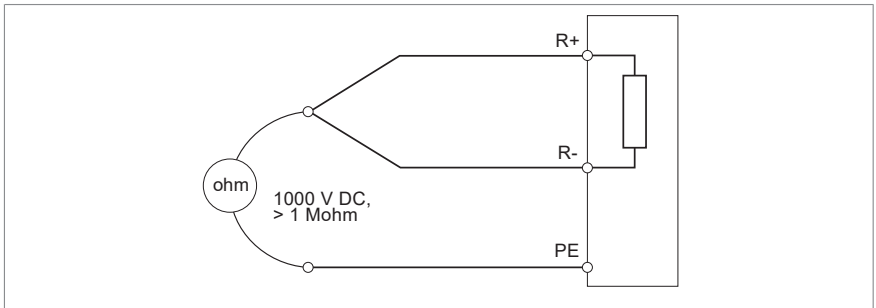

Grounding system compatibility check – North America

This section is applicable to the UL (NEC) drive types.

■ EMC filter

The drive has an internal EMC filter as standard. In the UL (NEC) drive types, the filter is disconnected by default. The filter is typically not necessary in North American installations.

If you are concerned with EMC issues, and install the drive to a symmetrically grounded TN-S system (center-grounded wye), you can connect the internal EMC filter. See [Disconnecting the ground-to-phase varistor, or connecting the EMC filter \(page 96\)](#).

Note: When the internal EMC filter is disconnected, the electromagnetic compatibility of the drive is decreased.





WARNING!

Do not install a drive with the internal EMC filter connected to a grounding system that the EMC filter is not compatible with (for example, an IT system). The supply network becomes connected to ground potential through the internal EMC filter capacitors, which can cause danger or damage to the drive.

■ **Ground-to-phase varistor**

The drive has a ground-to-phase varistor circuit as standard. You can install a drive that has the varistor circuit connected to a symmetrically grounded TN-S system (center-grounded wye). For other systems, refer to [Compatibility of EMC filter and ground-to-phase varistor with the grounding system \(page 94\)](#). In some product variants, the varistor circuit is disconnected at the factory.



WARNING!

Do not install the drive with the ground-to-phase varistor connected to a system that the varistor is not suitable for. It can cause damage to the varistor circuit.

■ **Compatibility of EMC filter and ground-to-phase varistor with the grounding system**



WARNING!

If you do not obey these instructions, injury to personnel or damage to the drive can occur.

A metal EMC screw is used to connect the internal EMC filter, and a metal VAR screw is used to connect the ground-to-phase varistor. The screws are installed at the factory. The material of the screws (plastic or metal) depends on the product



variant. Before you connect the drive to the input power, examine the screws and do the necessary actions shown in the table.

Screw label	Screw material	When to remove EMC screw or VAR screw		
		Symmetrically grounded TN-S systems, i.e, center-grounded wye (A)	Corner-grounded delta (B1), midpoint-grounded delta (B2) and TT (D) systems	IT systems (ungrounded or high-resistance grounded) (C)
EMC	Metal	Do not remove	Remove	Remove
	Plastic	Do not remove ¹⁾	Do not remove	Do not remove
VAR	Metal	Do not remove	Do not remove	Remove
	Plastic	Do not remove	Do not remove	Do not remove

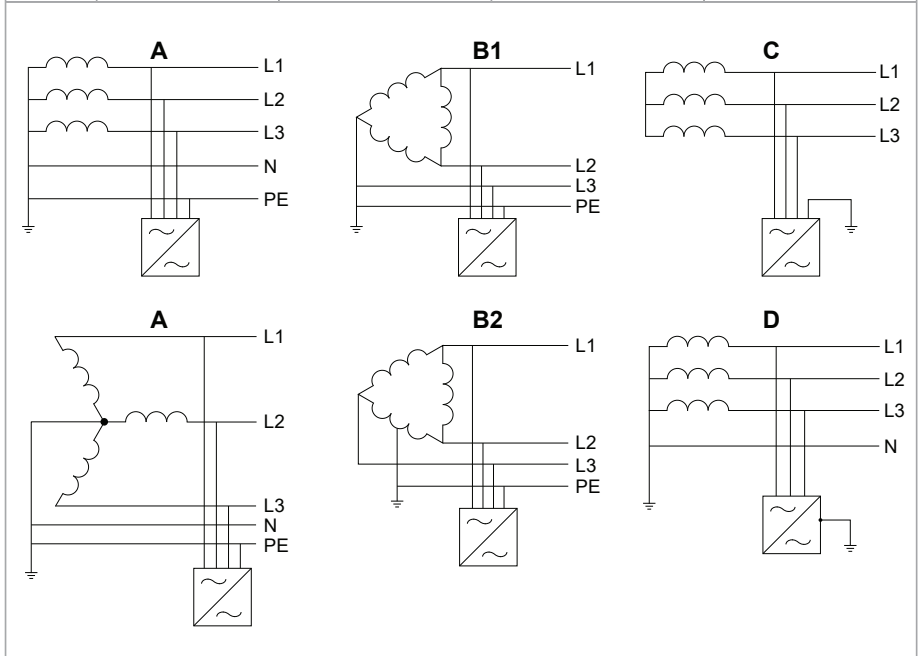

¹⁾ Can install the metal screw included in the drive delivery to connect the internal EMC filter.

For the locations of the screws, refer to [Disconnecting the ground-to-phase varistor, or connecting the EMC filter \(page 96\)](#).



■ **Disconnecting the ground-to-phase varistor, or connecting the EMC filter**

Before you continue, refer to [Compatibility of EMC filter and ground-to-phase varistor with the grounding system](#) (page 94).

- To disconnect the ground-to-phase varistor, remove the metal VAR screw.
- To connect the EMC filter, remove the plastic EMC screw, and replace it with the metal screw included in the drive delivery.

EMC/VAR screw location

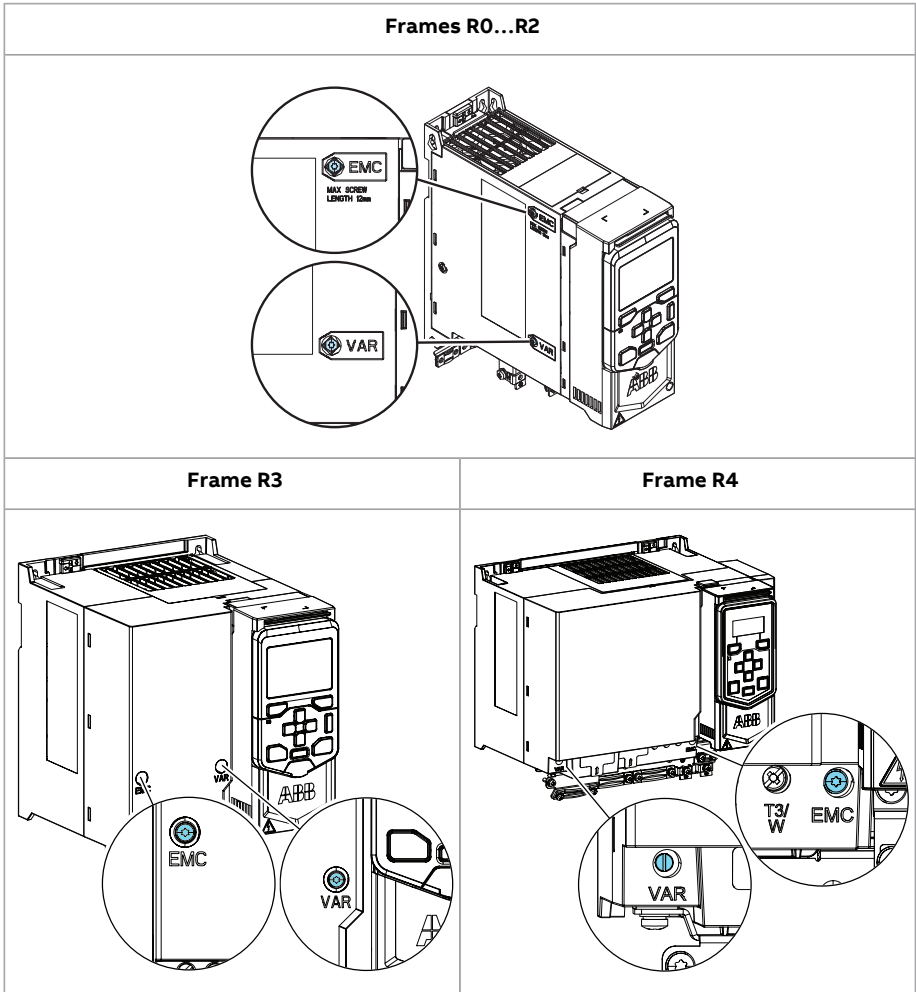

■ Guidelines for installing the drive to a TT system

You can install the drive to a TT system under these conditions:

1. There is a residual current device in the supply system
2. The internal EMC filter is disconnected. If the EMC filter is not disconnected, its leakage current will cause the residual current device to trip.

Note:

- ABB does not guarantee the EMC performance, because the internal EMC filter is disconnected.
- ABB does not guarantee the functioning of the ground leakage detector built inside the drive.
- In large systems the residual current device can trip without a real reason.

■ Identifying the grounding system of the electrical power network



WARNING!

Only a qualified electrical professional may do the work instructed in this section. Depending on the installation site, the work may even be categorized as live working. Continue only if you are an electrical professional certified for the work. Obey the local regulations. If you ignore them, injury or death can occur.

To identify the grounding system, examine the supply transformer connection. See the applicable electrical diagrams of the building. If that is not possible, measure these voltages at the distribution board, and use the table to define the grounding system type.

1. input voltage line to line (U_{L-L})
2. input voltage line 1 to ground (U_{L1-G})
3. input voltage line 2 to ground (U_{L2-G})
4. input voltage line 3 to ground (U_{L3-G}).



The table below shows the line-to-ground voltages in relation to the line-to-line voltage for each grounding system.

U_{L-L}	U_{L1-G}	U_{L2-G}	U_{L3-G}	Electrical power system type
X	0.58·X	0.58·X	0.58·X	TN-S system (symmetrically grounded)
X	1.0·X	1.0·X	0	Corner-grounded delta system (nonsymmetrical)
X	0.866·X	0.5·X	0.5·X	Midpoint-grounded delta system (nonsymmetrical)
X	Varying level versus time	Varying level versus time	Varying level versus time	IT systems (ungrounded or high-resistance-grounded [>30 ohms]) nonsymmetrical
X	Varying level versus time	Varying level versus time	Varying level versus time	TT system (the protective earth connection for the consumer is provided by a local earth electrode, and there is another independently installed at the generator)



Connecting the power cables – North America (wiring in conduits)

Use insulated wires suitable for installation in electrical conduits. See the National Electric Code and local ordinances.

■ Connection diagram

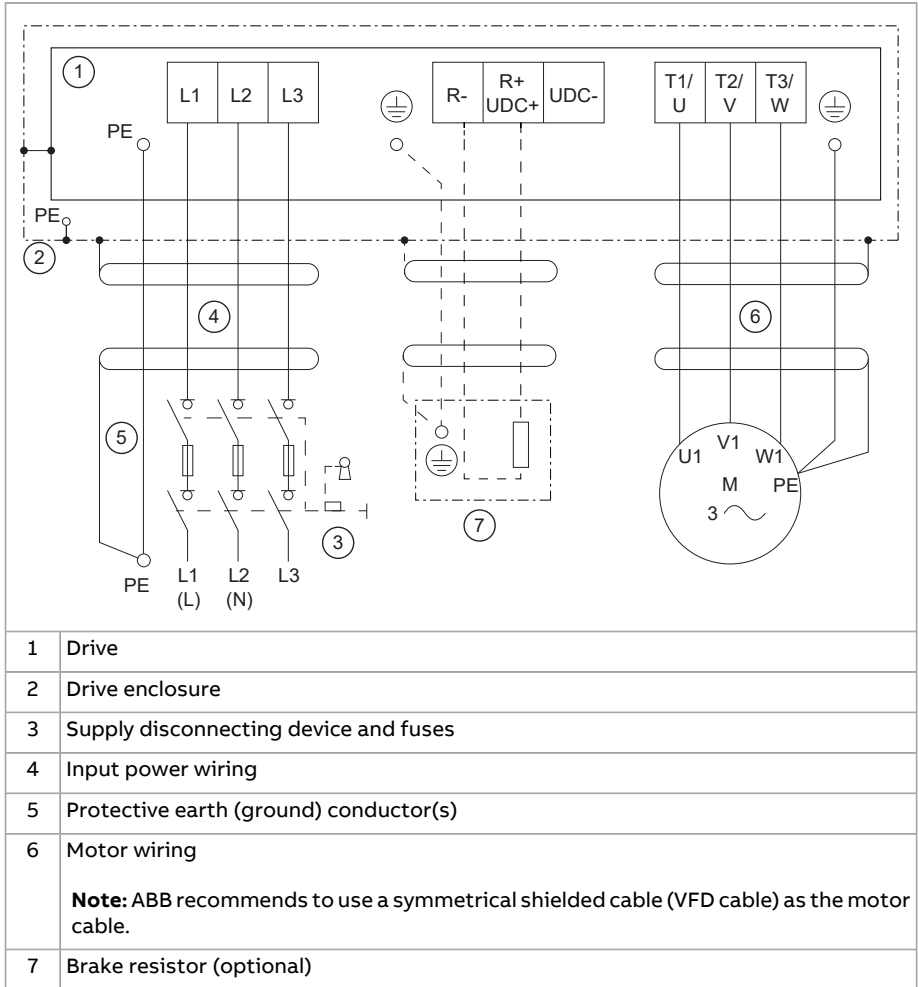

■ Connection procedure





WARNING!

Obey the safety instructions of the drive. If you ignore them, injury or death, or damage to the equipment can occur. If you are not a qualified electrical professional, do not do installation, commissioning or maintenance work.

Refer to [Terminal data for the power cables \(page 163\)](#) for the tightening torques.

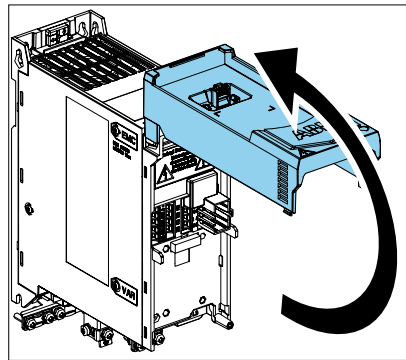
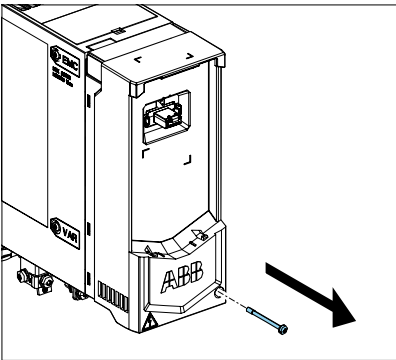
1. Do the steps in section [Electrical safety precautions \(page 18\)](#) before you start the work.
2. Install the conduits, and attach them to the cable entry plate of the enclosure that the drive is installed in.
3. Make sure that the conduit is correctly grounded at the cable entry.
4. Strip the conductor ends and pull the conductors through the conduits.
5. Remove the screw on the drive front cover, then lift the front cover up.



- 
6. Attach the residual voltage warning sticker in the local language to the drive.
 7. Connect the protective earth (ground) conductor of the motor wiring to the grounding terminal.

8. Connect the phase conductors of the motor wiring to terminals T1/U, T2/V and T3/W.

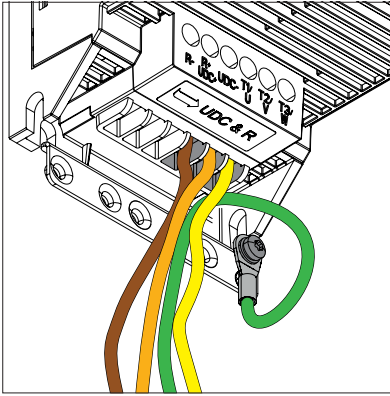

9. If you use a brake resistor, connect the brake resistor conductors to terminals R- and UDC+.
10. Make sure that the R- and UDC+ terminal screws are tightened. Do this step also if you do not connect cables to the terminals.
11. Connect the protective earth (ground) conductor(s) of the input power wiring to the grounding terminal.
12. Connect the phase conductors of the input power wiring to the drive as follows:
 - 1-phase drives: connect the phase and neutral conductors to terminals L1 and L2. For example, connect phase to L1 and neutral to L2.
 - 3-phase drives: connect the phase conductors to terminals L1, L2, and L3.



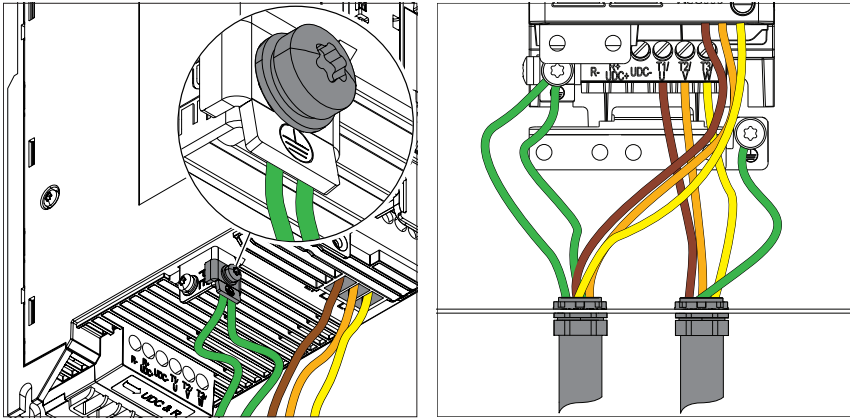

13. Connect the other ends of the conductors.

Connecting the control cables - North America

Before you connect the control cables, make sure that all option modules are installed.



■ Default I/O connection diagrams (ABB standard macro)

The connection diagrams below are applicable to the standard drive variant with the RIIO-01 I/O & EIA-485 module. ABB standard macro (parameter 96.04) is used with the default parameter settings.

Connection	Terminal ¹⁾	Description	2)
Analog inputs and outputs			
	1	SCR	Signal cable shield (screen)
	2	AI1	Output frequency: 0 ... 10 V
	3	AGND	Analog input circuit common
	4	+10V	Reference voltage 10 V DC
	5	AI2	Not configured
	6	AGND	Analog input circuit common
	7	AO1	Output frequency: 0 ... 20 mA
	8	AO2	Motor current: 0 ... 20 mA
	9	AGND	Analog output circuit common

Connection	Terminal ¹⁾	Description	2)		
Digital inputs and auxiliary voltage output					
	10	+24V	Aux. voltage output +24 V DC, max. 250 mA ³⁾	×	
	11	DGND	Aux. voltage output common	×	
	12	DCOM	Digital input common for all	×	
	13	DI1	Stop (0) / Start (1)	×	
	14	DI2	Forward (0) / Reverse (1)	×	
	15	DI3	Constant output frequency selection⁴⁾		
	16	DI4	Constant output frequency selection		
	17	DI5	Ramp set 1 (0) / Ramp set 2 (1)⁵⁾		
	18	DI6	Not configured		
	Relay outputs				
	10	+24V	Aux. voltage output +24 V DC, max. 250 mA ³⁾		
	11	DGND	Aux. voltage output common		
	12	DCOM	Digital input common for all		
	19	RO1C	Common	Ready run	×
	20	RO1A	Norm. closed	250 V AC / 30 V DC, 2 A	×
	21	RO1B	Norm. open		×
	22	RO2C	Common	Running	
	23	RO2A	Norm. closed	250 V AC / 30 V DC, 2 A	
	24	RO2B	Norm. open		
	25	RO3C	Common	Fault (-1)	
26	RO3A	Norm. closed	250 V AC / 30 V DC, 2 A		
27	RO3B	Norm. open			
Embedded EIA-485					
	29	B+	Embedded fieldbus (EIA-485)		
	30	A-			
	31	DGND			
S100	TERM	Termination switch. ON = on. 1 = off.			

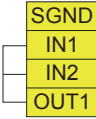

Connection	Terminal ¹⁾	Description	2)	
Safe torque off				
	34	SGND	Safe torque off. Factory connection. Both circuits must be closed for the drive to start.	x
	35	IN1		x
	36	IN2		x
	37	OUT1		x
Auxiliary voltage input/output				
	42	+24V	Aux. voltage output +24 V DC, max. 250 mA ³⁾	
	43	DGND	Aux. voltage output common	
	44	DCOM	Digital input common for all	

- 1) Terminal size: 0.14 ... 1.5 mm² (26 ... 16 AWG) Tightening torque: 0.5 ... 0.6 N·m (4.4 ... 5.3 lbf·in)
- 2) x = base unit, empty = RIIO-01 module
- 3) The sum output current from 24 V terminals of base unit and RIIO-01 module must not exceed 250 mA.
- 4) Drive output frequency:

D13	D14	Operation/Parameter
0	0	Set output frequency through AI1
1	0	28.26 Constant frequency 1
0	1	28.27 Constant frequency 2
1	1	28.28 Constant frequency 3

- 5) See parameters 28.72, 28.73, 28.74 and 28.75.

■ Default fieldbus connection diagram

The connection diagrams are applicable to the base unit with an optional fieldbus adapter module. ABB standard macro (parameter 96.04) is used with its default parameter settings.

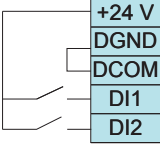
Connection	Terminal ¹⁾	Description	2)	
Auxiliary voltage output and digital inputs				
	10	+24V	Aux. voltage output +24 V DC, max. 250 mA	x
	11	DGND	Aux. voltage output common	x
	12	DCOM	Digital input common for all	x
	13	DI1	Stop (0) / Start (1)	x
	14	DI2	Forward (0) / Reverse (1)	x

Connection	Terminal ¹⁾	Description	2)		
Relay outputs					
	10	+24V	Aux. voltage output +24 V DC, max. 250 mA	×	
	11	DGND	Aux. voltage output common	×	
	12	DCOM	Digital input common for all	×	
	19	RO1C	Common	Ready run 250 V AC / 30 V DC, 2 A	×
	20	RO1A	Norm. closed		×
	21	RO1B	Norm. open		×
Safe torque off					
	34	SGND	Safe torque off. Factory connection. Both circuits must be closed for the drive to start.	×	
	35	IN1		×	
	36	IN2		×	
	37	OUT1		×	
Fieldbus connection					
See the applicable fieldbus adapter manual.	DSUB9	+K457 FCAN-01 CANopen			
	DSUB9	+K454 FPBA-01 Profibus DP			
	RJ45×2	+K469 FECA-01 EtherCAT			
	RJ45×2	+K475 FENA-21 Ethernet/IP, Profinet, Modbus TCP			
	RJ45×2	+K470 FEPL-02 Ethernet Powerlink			
	Terminal block	+K451 FDNA-01 DeviceNet			
	8P8C×2	+K462 FCNA-01 ControlNet			
	RJ45×2	+K490 FEIP-21 Two-port Modbus/IP adapter			
	RJ45×2	+K491 FMBT-21 Two-port Modbus/TCP adapter			
	RJ45×2	+K492 FPNO-21 Two-port Profinet IO adapter			

1) Terminal size: 0.14 ... 1.5 mm² (26 ... 16 AWG) Tightening torque: 0.5 ... 0.6 N·m (4.4 ... 5.3 lbf·in)

2) × = base unit, empty = fieldbus module

■ Control cable connection procedure

Do the connections according to the control macro (parameter 96.04) used.

Keep the signal wire pairs twisted as near to the terminals as possible to prevent inductive coupling.



WARNING!

Obey the safety instructions of the drive. If you ignore them, injury or death, or damage to the equipment can occur. If you are not a qualified electrical professional, do not do installation, commissioning or maintenance work.

1. Do the steps in section [Electrical safety precautions \(page 18\)](#) before you start the work.
2. Remove the screw on the drive front cover and lift the front cover up.
3. Strip a part of the outer shield of the control cable for grounding.
4. Use a cable tie to ground the outer shield to the grounding tab. For 360° grounding, use metallic cable ties.
5. Strip the control cable conductors.
6. Connect the conductors to the correct control terminals. Torque the terminal connections to 0.5 ... 0.6 N·m (4.4 ... 5.3 lbf-in).
7. Connect the shields and grounding wires to the SCR terminal. Torque the terminal connection to 0.5 ... 0.6 N·m (4.4 ... 5.3 lbf-in).
8. Mechanically attach the control cables on the outside of the drive.

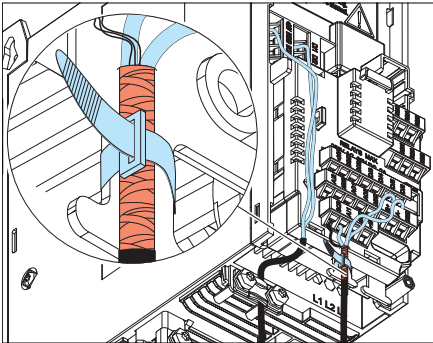

■ **Additional information on the control connections**

Embedded EIA-485 fieldbus connection

The EIA-485 network uses shielded, twisted-pair cable with a characteristic impedance of 100...130 ohm for data signaling. The distributed capacitance between conductors is less than 100 pF per meter (30 pF per foot). Distributed capacitance between conductors and shield is less than 200 pF per meter (60 pF per foot). Foil or braided shields are acceptable.

Connect the cable to the EIA-485 terminal on the RIIO-01 I/O module. Obey these wiring instructions:

- Attach the cable shields together at each drive, but do not connect them to the drive.
- Connect the cable shields only to the grounding terminal in the automation controller.
- Connect the signal ground (DGND) conductor to the signal ground reference terminal in the automation controller. If the automation controller does not have a signal ground reference terminal, connect the signal ground conductor to the cable shield through a 100 ohm resistor, preferably near the automation controller.

Connection examples are shown below.

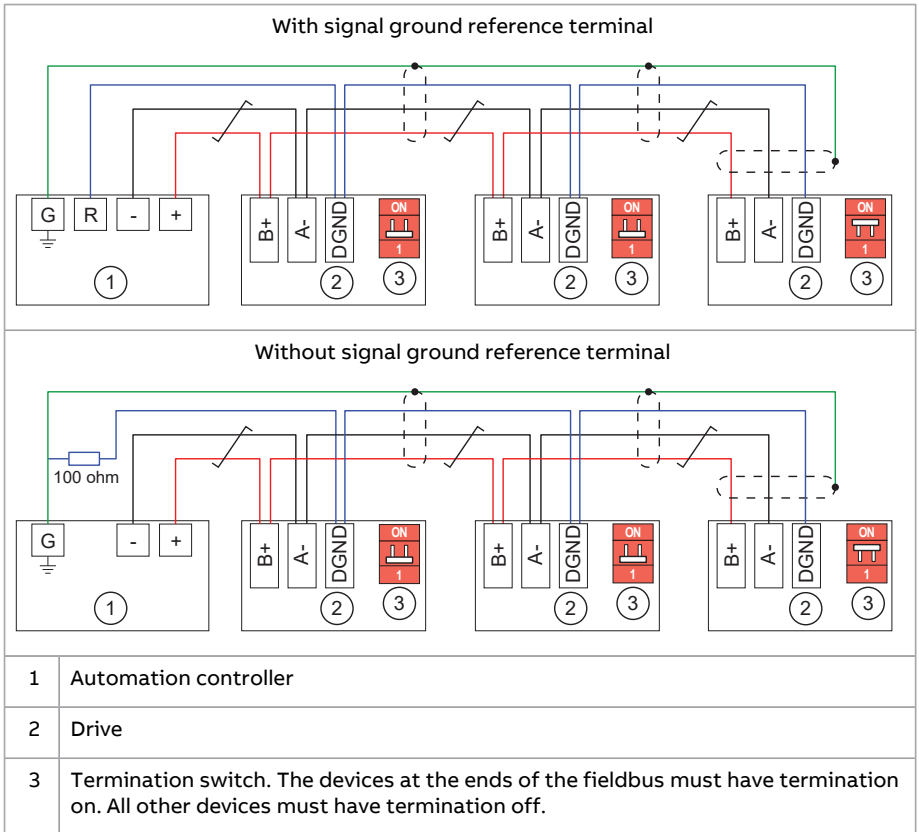

PNP configuration for digital inputs

Internal and external +24 V power supply connections for PNP (source) configuration are shown in the figures below.

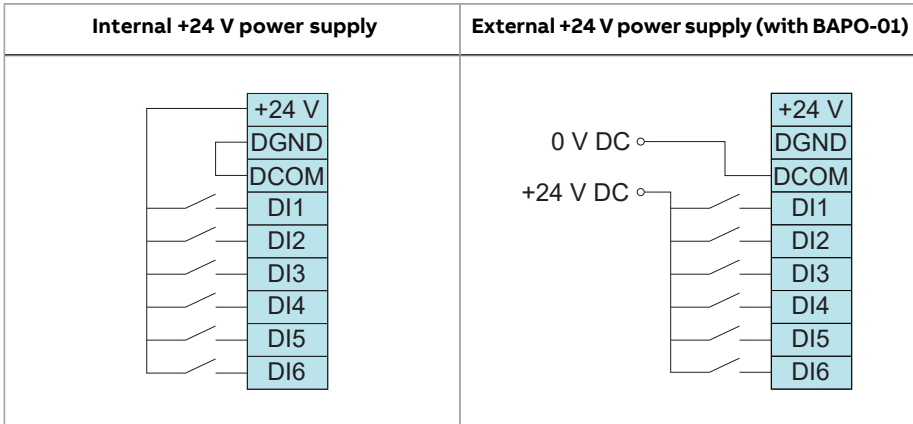

NPN configuration for digital inputs

Internal and external +24 V power supply connections for NPN (sink) configuration are shown in the figures below.

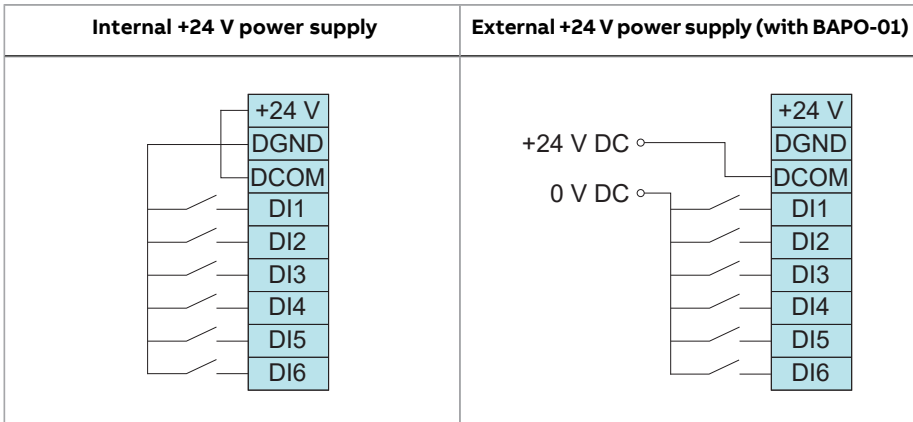

Connection for obtaining 0 ... 10 V from analog output 2 (AO2)

To obtain 0 ... 10 V from analog output AO2, connect a 500 ohm resistor (or two 1 kohm resistors in parallel) between AO2 and AGND. Examples are shown in the figure below.

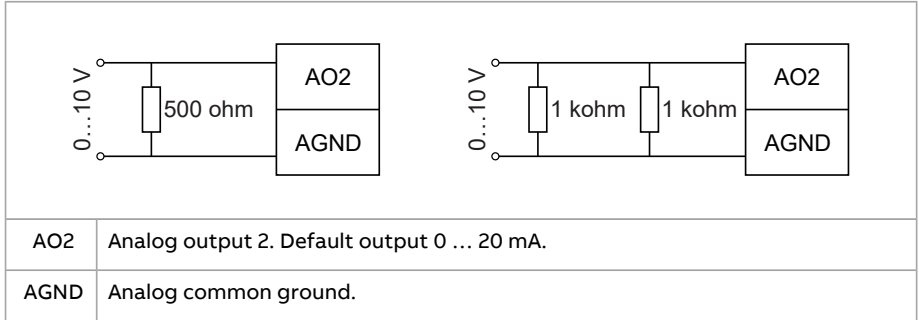

Connection examples of two-wire and three-wire sensors

The figures give examples of connections for a two-wire or three-wire sensor/transmitter that is supplied by the auxiliary voltage output of the drive.

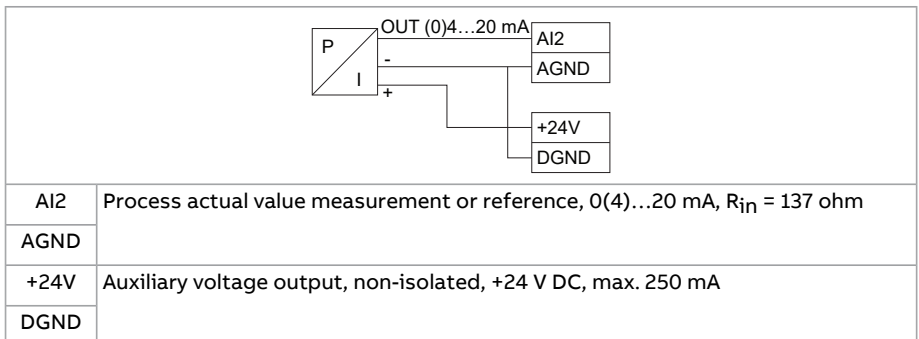
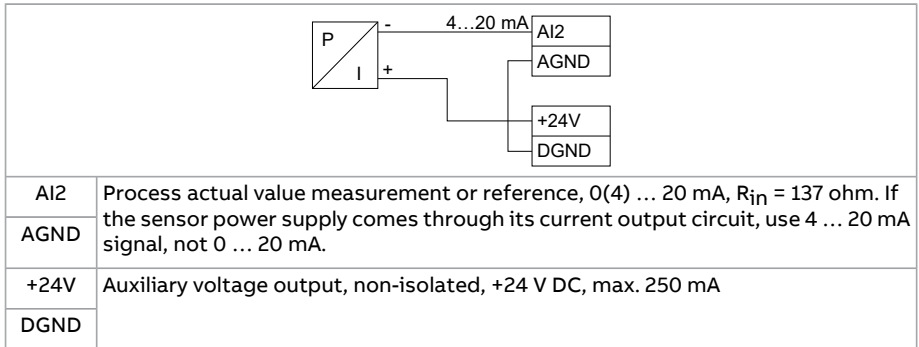

AI and AO (or AI, DI and +10 V) as PTC motor temperature sensor interface



WARNING!

IEC 61800-5-1 requires double or reinforced insulation between live parts and accessible parts when:

- the accessible parts are not conductive, or
- the accessible parts are conductive, but not connected to the protective earth.

Obey this requirement when you plan the connection of the motor temperature sensor to the drive.

To comply with the drive safety standard IEC 61800-5-1:

If the motor temperature sensor has double or reinforced insulation vs. the motor windings, you can connect it directly to the drive IO interface. This section shows two connection alternatives for the direct I/O connection. If the sensor does not have reinforced insulation, you must use another type of connection to comply with the safety standard. See [Implementing a motor temperature sensor connection \(page 60\)](#).

See the firmware manual for information on the related Motor thermal protection function, and the required parameter settings.

PTC connection 1

1...3 PTC sensors can be connected in series to an analog input and an analog output. Make sure that the voltage does not exceed the maximum allowed voltage over the sensor. The analog output feeds a constant excitation current of 1.6 mA through the sensor. The sensor resistance increases as the motor temperature rises, as does the voltage over the sensor. The temperature measurement function calculates the resistance of the sensor and generates an indication if overtemperature is detected. Leave the sensor end of the cable shield unconnected.



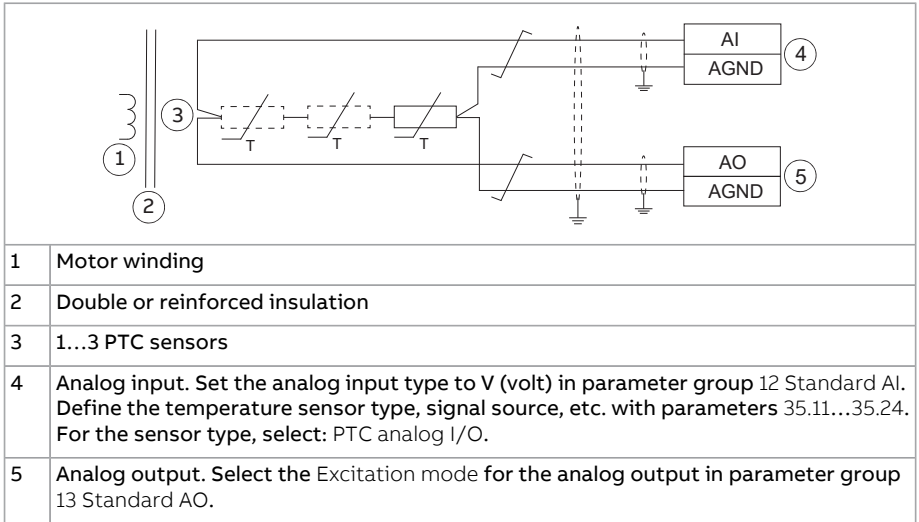

PTC connection 2

If no analog output is available for the PTC connection, it is possible to use a voltage divider connection. Make sure that the voltage does not exceed the maximum allowed voltage over the sensor. 1...3 PTC sensors are connected in series with 10 V reference and digital and analog inputs. The voltage over the digital input internal resistance varies depending on the PTC resistance. The temperature measurement function reads the digital input voltage through the analog input and calculates the PTC resistance.



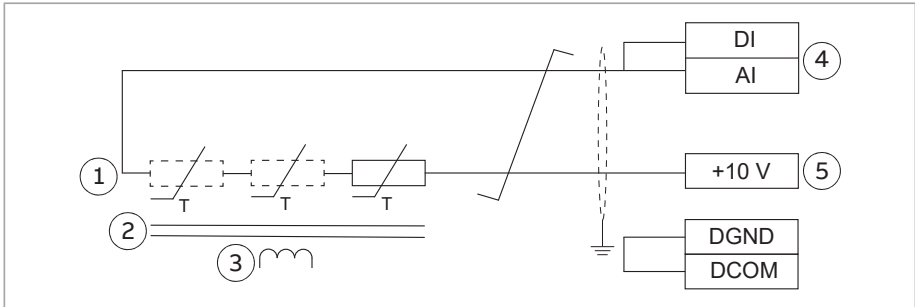

1	1...3 PTC sensors
2	Double or reinforced insulation
3	Motor winding
4	Digital input and analog input. Set the analog input type to V (volt) in parameter group 12 Standard AI. Define the temperature sensor type, signal source, etc. with parameters 35.11...35.24. For the sensor type, select: PTC AI/DI Voltage Divider tree. Make sure that the digital input is not configured to any other use by parameters.
5	10 V reference voltage

AI1 and AI2 as Pt100, Pt1000, Ni1000, KTY83 and KTY84 sensor inputs



WARNING!

IEC 61800-5-1 requires double or reinforced insulation between live parts and accessible parts when:

- the accessible parts are not conductive, or
- the accessible parts are conductive, but not connected to the protective earth.

Obey this requirement when you plan the connection of the motor temperature sensor to the drive.

To comply with the drive safety standard IEC 61800-5-1:

If the motor temperature sensor has double or reinforced insulation vs. the motor windings, you can connect it directly to the drive IO interface. This section shows the connection. If the sensor has no reinforced insulation, you must use another type of connection to comply with the safety standard. See [Implementing a motor temperature sensor connection \(page 60\)](#).

You can connect temperature measurement sensors (one, two or three Pt100 sensors; one, two or three Pt1000 sensors; or one Ni1000, KTY83 or KTY84) between an analog input and output as shown below. Make sure that the voltage does not exceed the maximum allowed voltage over the sensor. Leave the sensor end of the cable shield unconnected.

See the firmware manual for information on the related Motor thermal protection function.

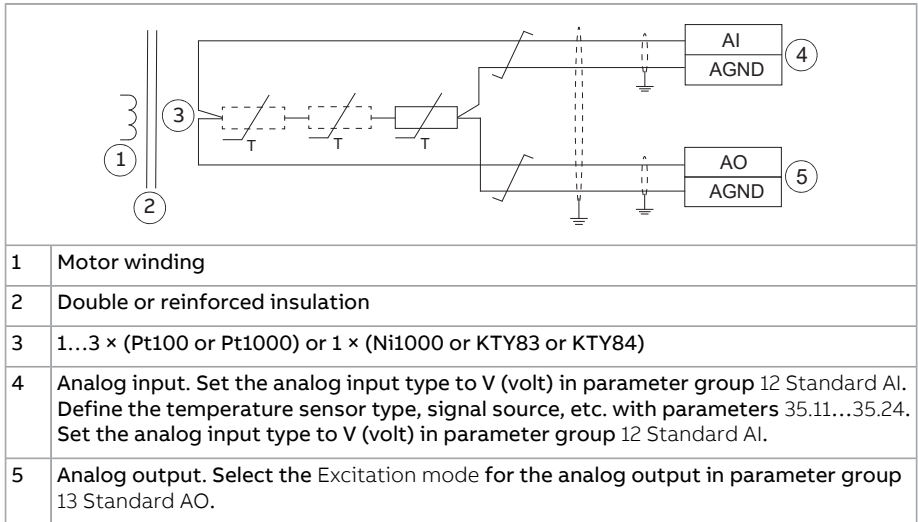

Safe torque off

For the drive to start, both STO connections (OUT1-IN1 and OUT1-IN2) must be closed. By default, the terminal block has jumpers to close the circuit. Remove the jumpers before connecting external Safe torque off circuitry to the drive. See chapter [The Safe torque off function](#).

Auxiliary voltage connection

The drive has 24 V DC ($\pm 10\%$) auxiliary power supply terminals both on the base unit and on the RIIO-01 module. You can use them:

- to supply auxiliary power from the drive to external control circuits or option modules
- to supply external auxiliary power to the drive to keep the control and cooling in operation if there is a power outage.

See the technical data for the specifications for the auxiliary power supply terminals (input/output).

To supply power to external control circuits or option modules:

1. Connect the load either to the auxiliary power output on the base unit, or on the RIIO-01 module (+24V and DGND terminals).
2. Make sure that you do not exceed the load capacity of the output, or the sum load capacity of both outputs.

To connect an external auxiliary power supply to the drive:

1. Install a BAPO-01 power extension module to the drive. See [Installing options \(page 86\)](#).
2. Connect an external power supply to the +24V and DGND terminals of the base unit.

For more information on the BAPO-01 module, see [BAPO-01 auxiliary power extension module \(page 245\)](#).

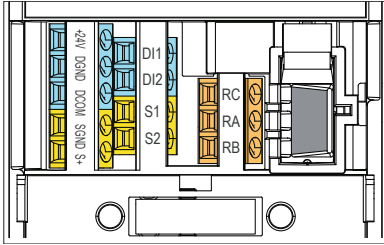

Connecting a PC

You can connect a PC to the drive. To communicate with the drive, the PC must have suitable software (for example, Drive composer) installed.

If you have an assistant control panel (ACS-AP-...), use a USB data cable (Type A - Type Mini-B, maximum length 3 m [9.8 ft]) to connect to the PC. Connect the cable as follows:

1. Open the USB connector cover on the control panel.
2. Connect the USB cable Mini-B plug to the control panel USB connector.
3. Connect the USB cable A plug to the USB port of the PC. The panel shows text "USB connected".

Note: You cannot use the control panel keys when the drive is connected to a PC.



If you have a RDUM-01 blank panel or CDPI-02 panel bus adapter installed, use a BCBL-01 USB-RJ45 converter to connect to the PC.

It is also possible to use a CCA-01 configuration adapter when the drive is not connected to the power supply network or to an external 24 V supply. The CCA-01 does not operate if the drive is powered.

Installing options

The drive has two option module slots:

- Front option: Communication module slot under the front cover.

- Side option: Multifunction extension module slot on the side of the drive.

Refer also to the applicable fieldbus module manual for the installation instructions. For other option modules, refer to:

- [BREL-01 relay output extension module \(page 255\)](#)
- [BAPO-01 auxiliary power extension module \(page 245\)](#)
- [BIO-01 I/O extension module \(page 249\)](#).

■ Installing a front option



WARNING!

Obey the safety instructions of the drive. If you ignore them, injury or death, or damage to the equipment can occur. If you are not a qualified electrical professional, do not do installation, commissioning or maintenance work.

1. Do the steps in section [Electrical safety precautions \(page 18\)](#) before you start the work.
2. Remove the screw on the drive front cover and lift the front cover up.
3. If the option module has a locking tab, pull it up.
4. Carefully align the option module with the option module slot and push it into position.
5. Torque the screw to 0.5 N·m (4.4 lbf·in).
6. If the option module has a locking tab, push it down until it locks.
7. Connect the control cables. See the control cable connection instructions.

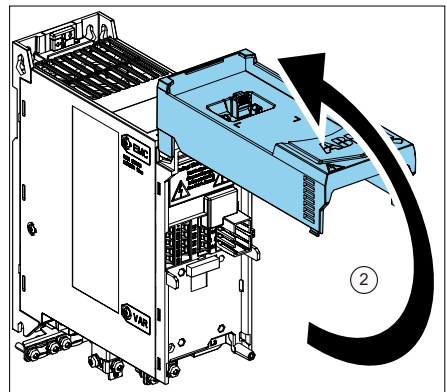
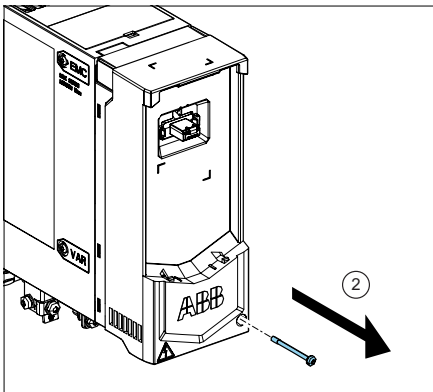

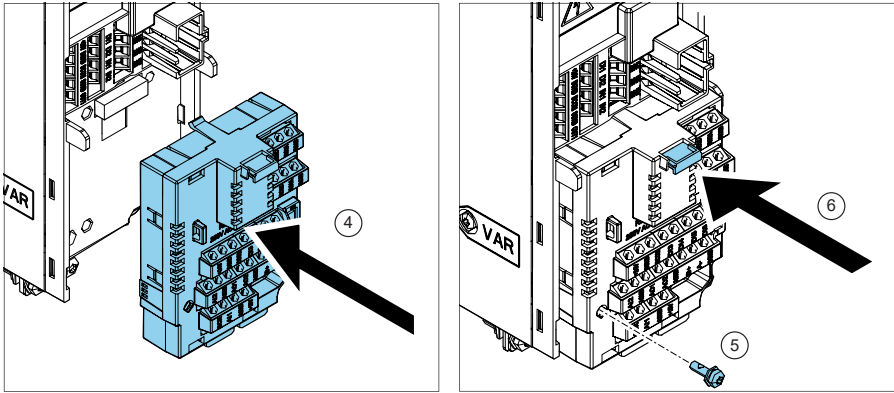

Note: If you have the BIO-01 option module, you can add one additional fieldbus module on top of it.

■ Installing a side option

⚠ WARNING! Obey the safety instructions of the drive. If you ignore them, injury or death, or damage to the equipment can occur. If you are not a qualified electrical professional, do not do installation, commissioning or maintenance work.

1. Do the steps in section [Electrical safety precautions \(page 18\)](#) before you start the work.
2. Remove the two screws from the front-most grounding clamp at the bottom of the drive.
3. Carefully align the side option with the connectors on the right side of the drive.
4. Fully push the option module into position.
5. Torque the screw on the option module to 1 N·m (8.8 lbf·in).



6. Attach the grounding bar to the bottom of the side option and to the front ground tab on the drive. Torque the screws to 1 N·m (8.8 lbf·in).
7. Connect the control cables. See the control cable connection instructions.

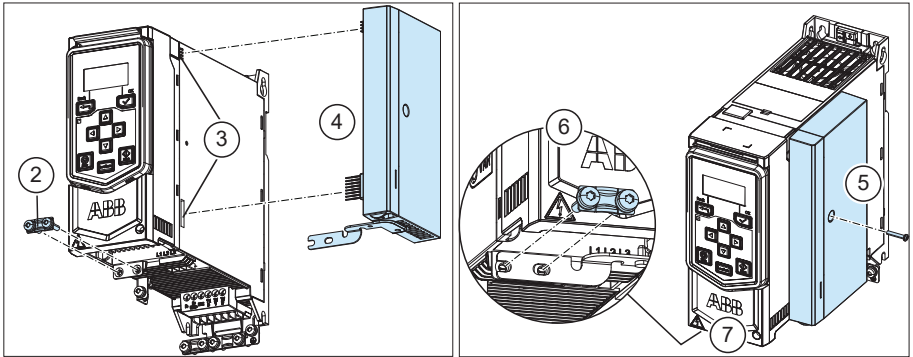

8

Installation checklist

Contents of this chapter

This chapter contains a checklist for the mechanical and electrical installation of the drive.

Checklist

Examine the mechanical and electrical installation of the drive before start-up. Go through the checklist together with another person.

WARNING!

Obey the safety instructions of the drive. If you ignore them, injury or death, or damage to the equipment can occur. If you are not a qualified electrical professional, do not do installation, commissioning or maintenance work.

WARNING!

Stop the drive and do the steps in section [Electrical safety precautions \(page 18\)](#) before you start the work.

Make sure that ...	<input checked="" type="checkbox"/>
The ambient operating conditions meet the drive ambient conditions specification and enclosure rating (IP code).	<input type="checkbox"/>
The supply voltage matches the nominal input voltage of the drive. See the type designation label.	<input type="checkbox"/>

120 Installation checklist

Make sure that ...	<input checked="" type="checkbox"/>
The insulation resistance of the input power cable, motor cable and motor is measured according to local regulations and the manuals of the drive.	<input type="checkbox"/>
The drive is attached securely on an even, vertical and non-flammable wall.	<input type="checkbox"/>
The cooling air can flow freely in and out of the drive.	<input type="checkbox"/>
<u>If the drive is connected to a network other than a symmetrically grounded TN-S system:</u> You have done all the required modifications (for example, you may need to disconnect the EMC filter or ground-to-phase varistor) the electrical installation instructions.	<input type="checkbox"/>
Appropriate AC fuses and main disconnecting device are installed.	<input type="checkbox"/>
There is an adequately sized protective earth (ground) conductor(s) between the drive and the switchboard, the conductor is connected to correct terminal, and the terminal is tightened to the correct torque. Grounding has also been measured according to the regulations.	<input type="checkbox"/>
The input power cable is connected to the correct terminals, the phase order is correct, and the terminals are tightened to the correct torque.	<input type="checkbox"/>
There is an adequately sized protective earth (ground) conductor between the motor and the drive. The conductor is connected to the correct terminal, and the terminal is tightened to the correct torque. Grounding has also been measured according to the regulations.	<input type="checkbox"/>
The motor cable is connected to the correct terminals, the phase order is correct, and the terminals are tightened to the correct torque.	<input type="checkbox"/>
The motor cable is routed away from other cables.	<input type="checkbox"/>
No power factor compensation capacitors are connected to the motor cable.	<input type="checkbox"/>
<u>If an external brake resistor is connected to the drive:</u> There is an adequately sized protective earth (ground) conductor between the brake resistor and the drive, and the conductor is connected to the correct terminal, and the terminals are tightened to the correct torque. Grounding has also been measured according to the regulations.	<input type="checkbox"/>
<u>If an external brake resistor is connected to the drive:</u> The brake resistor cable is connected to the correct terminals, and the terminals are tightened to the correct torque.	<input type="checkbox"/>
<u>If an external brake resistor is connected to the drive:</u> The brake resistor cable is routed away from other cables.	<input type="checkbox"/>

Make sure that ...	<input checked="" type="checkbox"/>
The control cables are connected to the correct terminals, and the terminals are tightened to the correct torque.	<input type="checkbox"/>
<u>If a drive bypass connection will be used:</u> The direct-on-line contactor of the motor and the drive output contactor are either mechanically and/or electrically interlocked, that is, they cannot be closed at the same time. A thermal overload device must be used for protection when bypassing the drive. Refer to local codes and regulations.	<input type="checkbox"/>
There are no tools, foreign objects or dust from drilling inside the drive.	<input type="checkbox"/>
The area in front of the drive is clean: the drive cooling fan cannot draw any dust or dirt inside.	<input type="checkbox"/>
Drive covers and the terminal box cover of the motor are in place.	<input type="checkbox"/>
The motor and the driven equipment are ready for power-up.	<input type="checkbox"/>

9

Maintenance

Contents of this chapter

The chapter contains maintenance intervals and instructions.

Maintenance intervals

The tables below show the maintenance tasks that can be done by the end user. For the ABB Service offering, contact your local ABB Service representative (www.abb.com/searchchannels).

■ Description of symbols

Action	Description
I	Inspection (visual inspection and maintenance action if needed)
P	Performance of on/off-site work (commissioning, tests, measurements or other work)
R	Replacement

■ **Recommended maintenance intervals after start-up**

Recommended annual actions by the user	
Connections and environment	
Quality of supply voltage	P
Spare parts	
Spare parts	I
Reforming DC circuit capacitors of spare modules	P
Inspections	
Tightness of terminals	I
Dustiness, corrosion and temperature	I
Cleaning the heatsink	P

Maintenance task/object	Years from start-up						
	3	6	9	12	15	18	21
Cooling fans (frames R1...R4)							
Main cooling fan		R		R		R	
Batteries							
Control panel battery			R			R	
Functional safety							
Safety function test	I See the maintenance information of the safety function.						
Safety component expiry (Mission time T_M)	20 years						

Note:

- The maintenance and component replacement intervals are based on the assumption that the equipment operates within the specified ratings and ambient conditions. ABB recommends annual drive inspections to ensure the highest reliability and optimum performance.
- Long-term operation near the specified maximum ratings or ambient conditions may require shorter maintenance intervals for certain components. Contact your local ABB Service representative for additional maintenance recommendations.

Functional safety components

The mission time of functional safety components is 20 years which equals the time during which failure rates of electronic components remain constant. This applies to the components of the standard Safe torque off circuit as well as any modules, relays and, typically, any other components that are part of functional safety circuits.

The expiry of mission time terminates the certification and SIL/PL classification of the safety function. The following options exist:

- Renewal of the whole drive and all optional functional safety module(s) and components.
- Renewal of the components in the safety function circuit. In practice, this is economical only with larger drives that have replaceable circuit boards and other components such as relays.

Note that some of the components may already have been renewed earlier, restarting their mission time. The remaining mission time of the whole circuit is however determined by its oldest component.

Contact your local ABB service representative for more information.

Cleaning the heatsink

The drive module heatsink fins pick up dust from the cooling air. The drive runs into overtemperature warnings and faults if the heatsink is not clean. When necessary, clean the heatsink as follows.



WARNING!

Use the required personal protective equipment. Wear protective gloves and long sleeves. Some parts have sharp edges.



WARNING!

Use a vacuum cleaner with antistatic hose and nozzle, and wear a grounding wristband. Using a normal vacuum cleaner creates static discharges which can damage circuit boards.

1. Stop the drive and do the steps in section [Electrical safety precautions \(page 18\)](#) before you start the work.
 2. Remove the module cooling fan(s). See the separate instructions.
 3. Protect the adjacent equipment from dust.
 4. Blow dry, clean and oil-free compressed air from bottom to top and simultaneously use a vacuum cleaner at the air outlet to trap the dust.
 5. Reinstall the cooling fan.
-

Replacing the cooling fans

These instructions are applicable only to drives with frame size R1...R4. Drives with frame size R0 do not have a cooling fan.

Parameter 05.04 Fan on-time counter shows the running time of the cooling fan. After you replace the fan, reset the fan counter. Refer to the firmware manual.

You can get replacement fans from ABB. Use only ABB specified spare parts.

■ Replacing the cooling fan, frames R1...R3

 **WARNING!** Obey the safety instructions of the drive. If you ignore them, injury or death, or damage to the equipment can occur. If you are not a qualified electrical professional, do not do installation, commissioning or maintenance work.

1. Stop the drive and do the steps in section [Electrical safety precautions \(page 18\)](#) before you start the work.
2. Use a suitable flat screwdriver to open the fan cover.
3. Carefully lift the fan cover out of the drive. The fan cover holds the cooling fan.

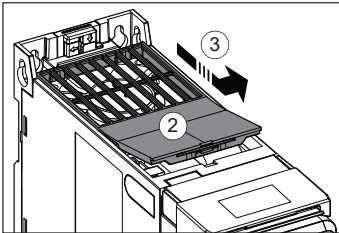

4. Remove the fan power cable from the cable slot in the drive.
5. Disconnect the fan power cable.

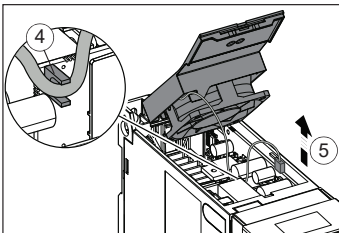

6. Free the fan clips and remove the fan from the fan cover.
-

7. Install the new fan into the fan cover. Make sure that the air flow is in the correct direction. The air flows in from the bottom of the drive and out from the top of the drive.

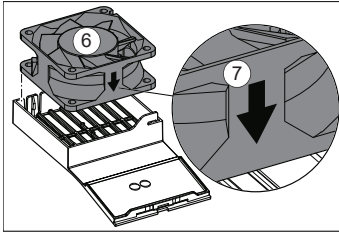

8. Connect the fan power cable.
9. Put the fan power cable into the cable slot in the drive.

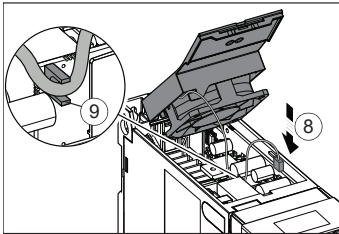

10. Carefully put the fan cover into position in the drive. Make sure that the fan power cable is routed correctly.
11. Push the cover to lock into position.

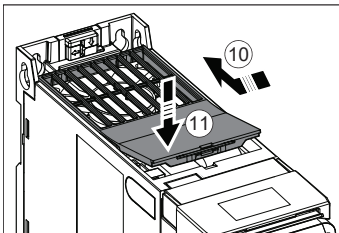

■ Replacing the cooling fan, frame R4



WARNING!

Obey the safety instructions of the drive. If you ignore them, injury or death, or damage to the equipment can occur. If you are not a qualified electrical professional, do not do installation, commissioning or maintenance work.

1. Stop the drive and do the steps in section [Electrical safety precautions \(page 18\)](#) before you start the work.
2. Use a suitable flat screwdriver to open the fan cover.

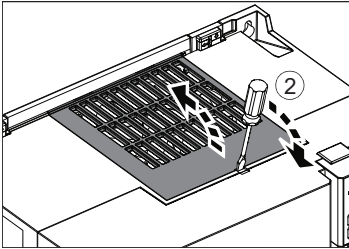

3. Lift out the fan cover and set it aside.

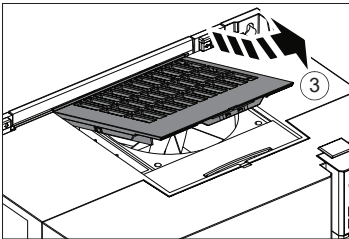

4. Lift and pull the fan from its base.
5. Disconnect the fan power cable from the extension cable connector.

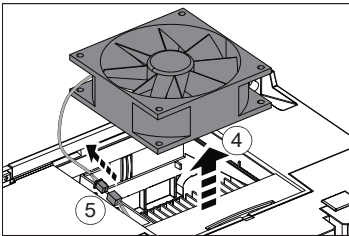

6. Replace the fan. The arrow indicating the air flow direction must point up.

7. Connect the fan power cable.

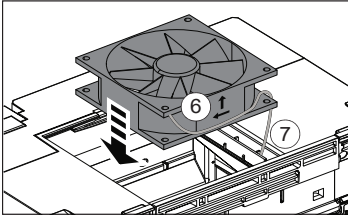

8. Place the fan cover back on the frame.
9. Push the cover to lock into position.

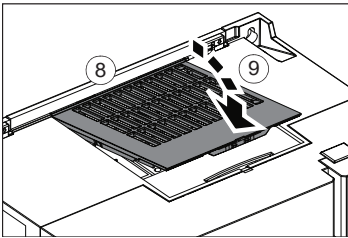

Capacitors

The intermediate DC circuit of the drive contains several electrolytic capacitors. Operating time, load, and surrounding air temperature have an effect on the life of the capacitors. Capacitor life can be extended by decreasing the surrounding air temperature.

Capacitor failure is usually followed by damage to the unit and an input cable fuse failure, or a fault trip. If you think that any capacitors in the drive have failed, contact ABB.

■ Reforming the capacitors

The capacitors must be reformed if the drive has not been powered (either in storage or unused) for a year or more. The manufacturing date is on the type designation label. For information on reforming the capacitors, refer to [Capacitor reforming instructions \(3BFE64059629 \[English\]\)](#).

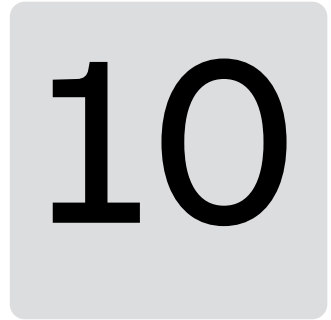

Technical data

Contents of this chapter

This chapter contains the technical specifications of the drive including the ratings, sizes and technical requirements, provisions for fulfilling the requirements for CE, UL and other approval marks.

Electrical ratings

■ IEC ratings

IEC type ACS480- 04-...	Input current		Output ratings							Frame
	No choke	With choke	Max. cur- rent	Nominal use		Light-duty use		Heavy-duty use		
	I_{1n}	I_{1n}	I_{max}	I_n	P_n	I_{Ld}	P_{Ld}	I_{Hd}	P_{Hd}	
	A	A	A	A	kW	A	kW	A	kW	
1-phase $U_n = 230\text{ V}$										
02A4-1	5.3	4.2	3.2	2.4	0.37	2.3	0.37	1.8	0.25	R0
03A7-1	7.0	6.4	4.3	3.7	0.55	3.5	0.55	2.4	0.37	R0
04A8-1	8.9	8.3	6.7	4.8	0.75	4.6	0.75	3.7	0.55	R1
06A9-1	11.5	11.9	8.6	6.9	1.1	6.6	1.1	4.8	0.75	R1
07A8-1	14.7	13.5	12.4	7.8	1.5	7.4	1.5	6.9	1.1	R1
09A8-1	19.8	17.0	14.0	9.8	2.2	9.3	2.2	7.8	1.5	R2

132 Technical data

IEC type ACS480- 04-...	Input current		Output ratings							Frame
	No choke	With choke	Max. current	Nominal use		Light-duty use		Heavy-duty use		
	I_{1n}	I_{1n}		I_{max}	I_n	P_n	I_{Ld}	P_{Ld}	I_{Hd}	
	A	A	A	A	kW	A	kW	A	kW	
12A2-1	25.6	21.1	17.6	12.2	3.0	11.6	3.0	9.8	2.2	R2
3-phase $U_n = 230\text{ V}$										
02A4-2	3.4	2.4	3.2	2.4	0.37	2.3	0.37	1.8	0.25	R1
03A7-2	4.5	3.7	4.3	3.7	0.55	3.5	0.55	2.4	0.37	R1
04A8-2	5.7	4.8	6.7	4.8	0.75	4.6	0.75	3.7	0.55	R1
06A9-2	7.8	6.9	8.6	6.9	1.1	6.6	1.1	4.8	0.75	R1
07A8-2	9.3	7.8	12.4	7.8	1.5	7.5	1.5	6.9	1.1	R1
09A8-2	12.8	9.8	14.0	9.8	2.2	9.3	2.2	7.8	1.5	R1
12A2-2	16.0	12.2	17.6	12.2	3.0	11.6	3.0	9.8	2.2	R2
17A5-2	20.7	17.5	22.0	17.5	4.0	16.7	4.0	12.2	3.0	R3
25A0-2	27.2	25.0	31.5	25.0	5.5	24.2	5.5	17.5	4.0	R3
032A-2	34.9	32.0	45.0	32.0	7.5	30.8	7.5	25.0	5.5	R4
048A-2	47.8	48.0	57.6	48.0	11.0	46.2	11.0	32.0	7.5	R4
3-phase $U_n = 400\text{ V}$										
02A7-4	3.5	2.6	3.2	2.6	0.75	2.5	0.75	1.8	0.55	R1
03A4-4	4.8	3.3	4.7	3.3	1.1	3.1	1.1	2.6	0.75	R1
04A1-4	6.1	4.0	5.9	4.0	1.5	3.8	1.5	3.3	1.1	R1
05A7-4	8.5	5.6	7.2	5.6	2.2	5.3	2.2	4.0	1.5	R1
07A3-4	10.1	7.2	10.1	7.2	3.0	6.8	3.0	5.6	2.2	R1
09A5-4	12.9	9.4	13.0	9.4	4.0	8.9	4.0	7.2	3.0	R1
12A7-4	16.5	12.6	16.9	12.6	5.5	12.0	5.5	9.4	4.0	R2
018A-4	23.4	17.0	22.7	17.0	7.5	16.2	7.5	12.6	5.5	R3
026A-4	31.8	25.0	30.6	25.0	11.0	23.8	11.0	17.0	7.5	R3
033A-4	40.7	32.0	45.0	32.0	15.0	30.5	15.0	25.0	11.0	R4
039A-4	49.0	38.0	57.6	38.0	18.5	36.0	18.5	32.0	15.0	R4
046A-4	55.7	45.0	68.4	45.0	22.0	42.8	22.0	38.0	18.5	R4
050A-4	55.7	50.0	81.0	50.0	22.0	48.0	22.0	45.0	22.0	R4

■ UL (NEC) ratings

UL (NEC) type ACS480- 04-...	Input current		Output ratings					Frame
	No choke	With choke	Max. current	Light-duty use		Heavy-duty use		
	I_{Ld}	I_{Ld}	I_{max}	I_{Ld}	P_{Ld}	I_{Hd}	P_{Hd}	
	A	A	A	A	hp	A	hp	
1-phase $U_n = 230\text{ V}$								
02A3-1	5.5	4.0	3.2	2.3	0.5	1.8	0.33	R0
03A5-1	7.4	6.1	4.3	3.5	0.75	2.3	0.5	R0
04A6-1	9.1	8.0	6.7	4.6	1.0	3.5	0.75	R1
06A6-1	12.6	11.4	8.6	6.6	1.5	4.6	1.0	R1
07A4-1	14.9	12.8	12.4	7.4	2.0	6.6	1.5	R1
09A3-1	21.0	16.1	14.0	9.3	3.0	7.4	2.0	R2
11A6-1	21.0	20.1	17.6	11.6	3.0	9.3	3.0	R2
3-phase $U_n = 230\text{ V}$								
02A3-2	3.5	2.3	3.2	2.3	0.5	1.8	0.33	R1
03A5-2	4.8	3.5	4.3	3.5	0.75	2.4	0.5	R1
04A6-2	5.8	4.6	6.7	4.6	1.0	3.2	0.75	R1
06A6-2	8.4	6.6	8.6	6.6	1.5	4.6	1.0	R1
07A5-2	9.4	7.5	12.4	7.5	2.0	6.6	1.5	R1
11A6-2	13.1	11.6	17.6	11.6	3.0	9.3	3.0	R2
017A-2	21.0	16.7	22.0	16.7	5.0	11.6	3.0	R3
024A-2	30.5	24.2	31.5	24.2	7.5	16.7	5.0	R3
031A-2	37.4	30.8	45.0	30.8	10.0	24.2	7.5	R4
046A-2	53.2	46.2	57.6	46.2	15.0	30.8	10.0	R4
3-phase $U_n = 480\text{ V}$								
02A1-4	2.7	2.1	3.2	2.1	1.0	1.6	0.75	R1
03A0-4	3.9	3.0	4.7	3.0	1.5	2.1	1.0	R1
03A5-4	4.5	3.4	5.9	3.4	2.0	3.0	1.5	R1
04A8-4	6.6	4.8	7.2	4.8	3.0	3.5	2.0	R1
06A0-4	6.2	6.0	10.1	6.0	3.0	4.8	3.0	R1
07A6-4	9.8	7.6	13.0	7.6	5.0	6.0	3.0	R1

UL (NEC) type ACS480- 04-...	Input current		Output ratings					Frame
	No choke	With choke	Max. current	Light-duty use		Heavy-duty use		
	I_{1Ld}	I_{1Ld}	I_{max}	I_{Ld}	P_{Ld}	I_{Hd}	P_{Hd}	
	A	A	A	A	hp	A	hp	
011A-4	13.9	11.0	16.9	11.0	7.5	7.6	5.0	R2
014A-4	18.8	14.0	22.7	14.0	10.0	11.0	7.5	R3
021A-4	26.6	21.0	30.6	21.0	15.0	14.0	10.0	R3
027A-4	33.7	27.0	45.0	27.0	20.0	21.0	15.0	R4
034A-4	41.3	34.0	57.6	34.0	25.0	27.0	20.0	R4
042A-4	46.9	42.0	81.0	42.0	30.0	40.0	30.0	R4

■ Definitions

The ratings are valid at a maximum surrounding air temperature of 50 °C (122 °F), with the default drive switching frequency of 4 kHz (parameter 97.01), and with an installation altitude below 1000 m (3281 ft).

U_n Nominal input voltage of the drive. For input voltage range U1, refer to [Electrical power network specification \(page 166\)](#).

I_{In} Nominal input current with typical motor power P_n . Continuous rms input current, for dimensioning cables and fuses.

I_{1Ld} Light-duty input current (rms) with typical motor power P_{Ld} , for dimensioning cables and fuses.

I_{max} Maximum output current. Available for 2 seconds every 10 minutes when the output frequency is less than 9 Hz. Otherwise maximum current is $1.5 \times I_{Hd}$. Maximum current setting (parameter 30.17) can also limit the value.

I_n Nominal output current. Maximum continuous rms output current (no overload).

P_n Typical motor power in nominal use (no overloading). The kilowatt ratings are applicable to most IEC 4-pole motors.

I_{Ld} Continuous rms output current. Allows 10% overload for 1 minute every 10 minutes.

P_{Ld} Typical motor power in light-duty use (10% overload). The kilowatt ratings are applicable to most IEC 4-pole motors. The horsepower ratings are applicable to most NEMA 4-pole motors.

I_{Hd}	Continuous rms output current. Allows 50% overload for 1 minute every 10 minutes.
P_{Hd}	Typical motor power in heavy-duty use (50% overload). The kilowatt ratings are applicable to most IEC 4-pole motors. The horsepower ratings are applicable to most NEMA 4-pole motors.

■ Sizing

ABB recommends the DriveSize tool for selecting the drive, motor and gear combination (<https://new.abb.com/drives/software-tools/drivesize>). You can also use the ratings tables.

The minimum recommended nominal current of the motor is 40% of the drive nominal output current (I_n). If the motor has a lower nominal current rating than this, the drive cannot accurately measure the motor current.

Output derating

The load capacity (I_n , I_{Ld} , I_{Hd}) decreases in some operation conditions. In such operation conditions, where full motor power is required, oversize the drive so that the total derated output current is sufficient for the motor to reach the full power.

In an environment where more than one type of derating is necessary (for example, high altitude and high temperature), the effects of derating are cumulative.

Note:

- I_{max} is not derated.
- It is possible that also the motor load capacity needs to be derated.
- You can also use the DriveSize tool for derating.

See [Surrounding air temperature derating \(page 138\)](#), [Altitude derating \(page 138\)](#) and [Switching frequency derating \(page 139\)](#) for the derating values.

Example 1, IEC: How to calculate the derated current

The drive type is ACS480-04-018A-4, which has a nominal output current (I_n) of 17 A at 400 V. Calculate the derated output current at 4 kHz switching frequency, at 1500 m altitude and at 55 °C surrounding air temperature.

Switching frequency derating: Derating is not necessary at 4 kHz.

Altitude derating: The derating factor for 1500 m is

$$1 - \frac{1500 \text{ m} - 1000 \text{ m}}{10000 \text{ m}} = 0.95$$

Surrounding air temperature derating: The derating factor for 55 °C surrounding air temperature is

$$1 - \frac{55\text{ }^{\circ}\text{C} - 50\text{ }^{\circ}\text{C}}{100\text{ }^{\circ}\text{C}} = 0.95$$

Multiply the nominal drive output current by all the applicable derating factors. In this example, the derated output current becomes

$$I_n = 17\text{ A} \cdot 0.95 \cdot 0.95 = 15.34\text{ A}$$

Example 1, UL (NEC): How to calculate the derated current

The drive type is ACS480-04-014A-4, which has light-duty output current (I_{Ld}) of 14 A at 480 V. Calculate the derated output current at 4 kHz switching frequency, at 6000 ft altitude and at 131 °F surrounding air temperature.

Switching frequency derating: Derating is not necessary at 4 kHz.

Altitude derating: The derating factor for 6000 ft is

$$1 - \frac{6000\text{ ft} - 3281\text{ ft}}{32810\text{ ft}} = 0.917$$

Surrounding air temperature derating: The derating factor for 131 °F surrounding air temperature is

$$1 - \frac{131\text{ }^{\circ}\text{F} - 122\text{ }^{\circ}\text{F}}{180\text{ }^{\circ}\text{F}} = 0.95$$

Multiply the drive output current by all the applicable derating factors. In this example, the derated output current becomes

$$I_{Ld} = 14\text{ A} \cdot 0.917 \cdot 0.95 = 12.2\text{ A}$$

Example 2, IEC: How to calculate the required drive

The application requires a nominal motor current of 6.0 A at a switching frequency of 8 kHz. The supply voltage is 400 V, the altitude is 1800 m and the surrounding air temperature is 35 °C.

Altitude derating: The derating factor for 1800 m is

$$1 - \frac{1800\text{ m} - 1000\text{ m}}{10000\text{ m}} = 0.92$$

Surrounding air temperature derating: Derating is not necessary at 35 °C surrounding air temperature.

To see if the derated output current of a drive is sufficient for the application, multiply the nominal output current (I_n) by all the applicable derating factors. For example, drive type ACS480-04-12A7-4 has a nominal output current of 12.6 A at 400 V.

Switching frequency derating: The derating factor for this drive type is 0.68 at 8 kHz. Calculate the derated drive output current:

$$I_n = 12.6\text{ A} \cdot 0.68 \cdot 0.92 = 7.88\text{ A}$$

In this example, the derated output current is sufficient, because it is higher than the required current.

Example 2, UL (NEC): How to calculate the required drive

The application requires a maximum of 12.0 A of motor current with a 10% overload for one minute every ten minutes (I_{Ld}) at a switching frequency of 8 kHz. The supply voltage is 480 V, the altitude is 5500 ft and the surrounding air temperature is 95 °F.

Altitude derating: The derating factor for 5500 ft is

$$1 - \frac{5500 \text{ ft} - 3281 \text{ ft}}{32810 \text{ ft}} = 0.932$$

Surrounding air temperature derating: Derating is not necessary at 95 °F surrounding air temperature.

To see if the derated output current of a drive is sufficient for the application, multiply the drive output current for light-duty use (I_{Ld}) by all the applicable derating factors. For example, drive type ACS480-04-21A-4 has an output current of 21 A at 480 V.

Switching frequency derating: The derating factor for this drive type is 0.67 at 8 kHz. Calculate the derated drive output current:

$$I_{Ld} = 21 \text{ A} \cdot 0.67 \cdot 0.932 = 13.11 \text{ A}$$

In this example, the derated output current is sufficient, because it is higher than the required current.

■ **Surrounding air temperature derating**

Frame	Temperature	Derating
All	Less than 50 °C (122 °F)	No derating
R1...R3	50 ... 60 °C (122 ... 140 °F)	Output current decreases by 1% for each additional 1 °C (1.8 F).
R4	50 ... 60 °C (122 ... 140 °F)	Output current decreases by 1% for each additional 1 °C (1.8 F) on: IEC types <ul style="list-style-type: none"> • ACS480-04-033A-4 • ACS480-04-046A-4 UL (NEC) types <ul style="list-style-type: none"> • ACS480-04-027A-4 Output current decreases by 2% for each additional 1 °C (1.8 F) on: IEC types <ul style="list-style-type: none"> • ACS480-04-039A-4 • ACS480-04-050A-4 UL (NEC) types <ul style="list-style-type: none"> • ACS480-04-034A-4 • ACS480-04-042A-4

■ **Altitude derating**

230 V drives: At altitudes 1000 ... 2000 m (3281 ... 6562 ft) above sea level, the derating is 1% for each added 100 m (328 ft) above 1000 m (3281 ft).

400/480 V drives: At altitudes 1000 ... 4000 m (3281 ... 13123 ft) above sea level, the derating is 1% for each added 100 m (328 ft) above 1000 m (3281 ft). In addition:

- A maximum altitude of 4000 m (13123 ft) is permitted for these grounding systems: TN-S, TT. A maximum altitude of 2000 m (6562 ft) is permitted for these grounding systems: corner-grounded delta, midpoint-grounded delta, IT (ungrounded).
- Above 2000 m (6562 ft), the maximum permitted voltage for the relay output RO1 decreases. At 4000 m (13123 ft), it is 30 V.
- Above 2000 m (6562 ft), the maximum permitted potential difference between the adjacent relays of the BREL-01 relay extension module (option +L511) decreases. At 4000 m (13123 ft), it is 30 V.

To calculate the derated output current, multiply the current in the ratings table with the derating factor *k*, which for *x* meters or feet is:

$$k = 1 - \frac{x - 1000 \text{ m}}{10000 \text{ m}}$$

$$k = 1 - \frac{x - 3281 \text{ ft}}{32810 \text{ ft}}$$

■ Switching frequency derating

Derating the drive output current is necessary when using high minimum switching frequencies. If you change parameter 97.02 Minimum switching frequency, calculate the derated current. Multiply the drive output current with the applicable derating factor from the table.

Derating is not necessary when changing parameter 97.01 Switching frequency reference.

Frame R4: If the application is cyclic and the surrounding air temperature is constantly more than 40 °C (104 °F), keep parameter 97.02 Minimum switching frequency at its default value (1.5 kHz). Higher switching frequencies decrease the product life time or the performance in the temperature range 40 ... 60 °C (104 ... 140 °F).

IEC type ACS480- 04-...	Derating factor		
	≤ 4 kHz	8 kHz	12 kHz
1-phase $U_n = 230 \text{ V}$			
02A4-1	1.0	0.80	0.66
03A7-1	1.0	0.80	0.66
04A8-1	1.0	0.81	0.68
06A9-1	1.0	0.81	0.68
07A8-1	1.0	0.85	0.74
09A8-1	1.0	0.85	0.74
12A2-1	1.0	0.82	0.69
3-phase $U_n = 230 \text{ V}$			
02A4-2	1.0	0.84	0.73
03A7-2	1.0	0.84	0.73
04A8-2	1.0	0.84	0.73
06A9-2	1.0	0.84	0.73
07A8-2	1.0	0.83	0.70
09A8-2	1.0	0.83	0.70
12A2-2	1.0	0.76	0.61
17A5-2	1.0	0.76	0.61
25A0-2	1.0	0.75	0.60

140 Technical data

IEC type ACS480- 04-...	Derating factor		
	≤ 4 kHz	8 kHz	12 kHz
032A-2	1.0	0.75	0.59
048A-2	1.0	0.74	0.60
3-phase $U_n = 400$ V			
02A7-4	1.0	0.65	0.48
03A4-4	1.0	0.65	0.48
04A1-4	1.0	0.65	0.48
05A7-4	1.0	0.65	0.48
07A3-4	1.0	0.65	0.48
09A5-4	1.0	0.65	0.48
12A7-4	1.0	0.68	0.51
018A-4	1.0	0.68	0.51
026A-4	1.0	0.67	0.51
033A-4	1.0	0.65	0.49
039A-4	1.0	0.65	0.49
046A-4	1.0	0.66	0.49
050A-4	1.0	0.66	0.49

UL (NEC) type ACS480- 04-...	Derating factor		
	≤ 4 kHz	8 kHz	12 kHz
1-phase $U_n = 230$ V			
02A3-1	1.0	0.80	0.66
03A5-1	1.0	0.80	0.66
04A6-1	1.0	0.81	0.68
06A6-1	1.0	0.81	0.68
07A4-1	1.0	0.85	0.74
09A3-1	1.0	0.85	0.74
11A6-1	1.0	0.82	0.69
3-phase $U_n = 230$ V			
02A3-2	1.0	0.84	0.73

UL (NEC) type ACS480- 04-...	Derating factor		
	≤ 4 kHz	8 kHz	12 kHz
03A5-2	1.0	0.84	0.73
04A6-2	1.0	0.84	0.73
06A6-2	1.0	0.84	0.73
07A5-2	1.0	0.83	0.70
11A6-2	1.0	0.76	0.61
017A-2	1.0	0.76	0.61
024A-2	1.0	0.75	0.60
031A-2	1.0	0.75	0.59
046A-2	1.0	0.74	0.60
3-phase $U_n = 480$ V			
02A1-4	1.0	0.65	0.48
03A0-4	1.0	0.65	0.48
03A5-4	1.0	0.65	0.48
04A8-4	1.0	0.65	0.48
06A0-4	1.0	0.65	0.48
07A6-4	1.0	0.65	0.48
011A-4	1.0	0.68	0.51
014A-4	1.0	0.68	0.51
021A-4	1.0	0.67	0.51
027A-4	1.0	0.65	0.49
034A-4	1.0	0.65	0.49
042A-4	1.0	0.66	0.49

■ Derating in case of a phase loss

In case of a phase loss the drive will function according to the settings of parameter 31.21 Supply phase loss. If No action is selected, the output current is limited to 50 % when phase loss is detected. No fault or warning is given.

Fuses

The tables list the fuses for protection against short-circuits in the input power cable or drive. The operating time depends on the supply network impedance, and the cross-sectional area and length of the supply cable.

Do not use fuses that have a higher current rating than specified in the table. You can use fuses from other manufacturers, if they meet the ratings, and if the melting curve of the fuse does not exceed the melting curve of the fuse mentioned in the table.

■ IEC fuses

Either fuse type can be used if it operates rapidly enough.

gG fuses (IEC)

Make sure that the operating time of the fuse is less than 0.5 seconds. Obey the local regulations.

IEC type ACS480-04-...	Min. short-circuit current ¹⁾	gG fuses				
		Nominal current	I ² t	Voltage rating	ABB type	IEC 60269 size
	A	A ² s	V			
1-phase U _n = 230 V						
02A4-1	80	10	380	500	OFAF000H10	000
03A7-1	80	10	380	500	OFAF000H10	000
04A8-1	128	16	720	500	OFAF000H16	000
06A9-1	200	20	1500	500	OFAF000H20	000
07A8-1	200	25	2500	500	OFAF000H25	000
09A8-1	256	32	2500	500	OFAF000H32	000
12A2-1	320	35	7000	500	OFAF000H35	000
3-phase U _n = 230 V						
02A4-2	48	6	110	500	OFAF000H6	000
03A7-2	80	10	360	500	OFAF000H10	000
04A8-2	80	10	360	500	OFAF000H10	000
06A9-2	128	16	740	500	OFAF000H16	000
07A8-2	128	16	740	500	OFAF000H16	000
09A8-2	128	16	740	500	OFAF000H16	000
12A2-2	200	25	2500	500	OFAF000H25	000

IEC type ACS480-04-...	Min. short-circuit current ¹⁾	gG fuses				
		Nominal current	I^2t	Voltage rating	ABB type	IEC 60269 size
		A	A^2s	V		
17A5-2	256	32	4500	500	OFAF000H32	000
25A0-2	400	50	15500	500	OFAF000H50	000
032A-2	504	63	20000	500	OFAF000H63	000
048A-2	800	100	65000	500	OFAF000H100	000
3-phase $U_n = 400$ V						
02A7-4	48	6	110	500	OFAF000H6	000
03A4-4	48	6	110	500	OFAF000H6	000
04A1-4	80	10	360	500	OFAF000H10	000
05A7-4	80	10	360	500	OFAF000H10	000
07A3-4	128	16	740	500	OFAF000H16	000
09A5-4	128	16	740	500	OFAF000H16	000
12A7-4	200	25	2500	500	OFAF000H25	000
018A-4	256	32	4500	500	OFAF000H32	000
026A-4	400	50	15500	500	OFAF000H50	000
033A-4	504	63	20000	500	OFAF000H63	000
039A-4	640	80	36000	500	OFAF000H80	000
046A-4	800	100	65000	500	OFAF000H100	000
050A-4	800	100	65000	500	OFAF000H100	000

¹⁾ Minimum permitted short-circuit current of the electrical power network

gR fuses (IEC)

IEC type ACS480-04-...	Min. short-circuit current ¹⁾	gR fuses				
		Nominal current	I^2t	Voltage rating	Bussmann type	IEC 60269 size
		A	A^2s	V		
1-phase $U_n = 230$ V						
02A4-1	80	32	275	690	170M2695	00
03A7-1	80	32	275	690	170M2695	00
04A8-1	128	40	490	690	170M2696	00

144 Technical data

IEC type ACS480-04...	Min. short-circuit current ¹⁾	gR fuses				
		Nominal current	I^2t	Voltage rating	Bussmann type	IEC 60269 size
	A	A	A ² s	V		
06A9-1	200	50	1000	690	170M2697	00
07A8-1	200	63	1800	690	170M2698	00
09A8-1	256	63	1800	690	170M2698	00
12A2-1	320	63	1800	690	170M2698	00
3-phase $U_n = 230$ V						
02A4-2	48	25	125	690	170M2694	00
03A7-2	80	32	275	690	170M2695	00
04A8-2	80	32	275	690	170M2695	00
06A9-2	128	40	490	690	170M2696	00
07A8-2	128	40	490	690	170M2696	00
09A8-2	128	40	490	690	170M2696	00
12A2-2	200	50	1000	690	170M2697	00
17A5-2	256	63	1800	690	170M2698	00
25A0-2	400	80	3600	690	170M2699	00
032A-2	504	100	6650	690	170M2700	00
048A-2	800	160	22500	690	170M2702	00
3-phase $U_n = 400$ V						
02A7-4	48	25	125	690	170M2694	00
03A4-4	48	25	125	690	170M2694	00
04A1-4	80	32	275	690	170M2695	00
05A7-4	80	32	275	690	170M2695	00
07A3-4	128	40	490	690	170M2696	00
09A5-4	128	40	490	690	170M2696	00
12A7-4	200	50	1000	690	170M2697	00
018A-4	256	63	1800	690	170M2698	00
026A-4	400	80	3600	690	170M2699	00
033A-4	504	100	6650	690	170M2700	00
039A-4	640	125	12000	690	170M2701	00

IEC type ACS480-04-...	Min. short-circuit current ¹⁾	gR fuses				
		Nominal current	I^2t	Voltage rating	Bussmann type	IEC 60269 size
		A	A^2s	V		
046A-4	800	160	22500	690	170M2702	00
050A-4	800	160	22500	690	170M2702	00

¹⁾ Minimum permitted short-circuit current of the electrical power network

■ UL (NEC) fuses

UL (NEC) type ACS480- 04-...	Fuses				
	Nominal cur- rent	Voltage rating	Bussmann/ Edison type	Type	Max. fuse rat- ing for group installation ¹⁾
	A	V			A
1-phase $U_n = 230\text{ V}$					
02A3-1	10	300	JJN/TJN10	UL class T	10
03A5-1	10	300	JJN/TJN10	UL class T	10
04A6-1	20	300	JJN/TJN20	UL class T	25
06A6-1	20	300	JJN/TJN20	UL class T	25
07A4-1	25	300	JJN/TJN25	UL class T	25
09A3-1	25	300	JJN/TJN25	UL class T	35
11A6-1	35	300	JJN/TJN35	UL class T	35
3-phase $U_n = 230\text{ V}$					
02A3-2	6	600	JJS/TJS6	UL class T	25
03A5-2	10	600	JJS/TJS10	UL class T	25
04A6-2	10	600	JJS/TJS10	UL class T	25
06A6-2	15	600	JJS/TJS15	UL class T	25
07A5-2	15	600	JJS/TJS15	UL class T	25
11A6-2	20	600	JJS/TJS20	UL class T	30
017A-2	30	600	JJS/TJS30	UL class T	40
024A-2	40	600	JJS/TJS40	UL class T	40
031A-2	50	600	JJS/TJS50	UL class T	100
046A-2	70	600	JJS/TJS70	UL class T	100

UL (NEC) type ACS480- 04-...	Fuses				
	Nominal current	Voltage rating	Bussmann/ Edison type	Type	Max. fuse rating for group installation ¹⁾
	A	V			A
3-phase $U_n = 480\text{ V}$					
02A1-4	6	600	JJS/TJS6	UL class T	25
03A0-4	6	600	JJS/TJS6	UL class T	25
03A5-4	6	600	JJS/TJS6	UL class T	25
04A8-4	10	600	JJS/TJS10	UL class T	25
06A0-4	10	600	JJS/TJS10	UL class T	25
07A6-4	15	600	JJS/TJS15	UL class T	25
011A-4	20	600	JJS/TJS20	UL class T	30
014A-4	25	600	JJS/TJS25	UL class T	40
021A-4	35	600	JJS/TJS35	UL class T	40
027A-4	45	600	JJS/TJS45	UL class T	100
034A-4	60	600	JJS/TJS60	UL class T	100
042A-4	60	600	JJS/TJS60	UL class T	100

¹⁾ Branch circuit short-circuit protection for group installation by fuses: Suitable for motor group installation on a circuit that is capable of delivering no more than 65000 rms symmetrical amperes, 480 V maximum, when protected by class T fuses. The same fuse size is specified for several consecutive drive types. This is possible since the physical structure of the drive types is identical.

1. Fuses are required as part of the installation, are not included in the base drive configuration and must be provided by others.
2. Fuses with a higher current rating than specified must not be used.
3. The UL listed fuses recommended by ABB are the required branch circuit protection per NEC.
4. The recommended size or smaller UL listed 248 fast acting, time delay, or high speed fuses must be used to maintain the UL listing of the drive. Additional protection can be used. Refer to local codes and regulations.
5. A fuse of a different class can be used at the high fault rating where the I_{peak} and I^2t of the new fuse is not greater than that of the specified fuse.
6. UL listed 248 fast acting, time delay, or high speed fuses from other manufacturers can be used if they meet the same class and rating requirements specified in the rules above.

7. When you install a drive, always obey ABB installation instructions, NEC requirements and local codes.
8. Alternative fuses can be used if they meet certain characteristics. For permitted fuses, refer to the alternative fuse tables in this manual.

UL (NEC) fuse alternatives

UL (NEC) type ACS480-04-...	Fuse		UL 248-15 Class T Fast Acting Fuses			
	Max. current	Voltage rating	Bussmann	Littelfuse	Mersen / Ferraz Shawmut	Edison
	A	V				
3-phase $U_n = 230$ V						
02A3-2	6	600	JJS-6	JLLS006	A6T6	TSJ6
03A5-2	10	600	JJS-10	JLLS010	A6T10	TSJ10
04A6-2	10	600	JJS-10	JLLS010	A6T10	TSJ10
06A6-2	20	600	JJS-20	JLLS020	A6T20	TSJ20
07A5-2	20	600	JJS-20	JLLS020	A6T20	TSJ20
11A6-2	25	600	JJS-25	JLLS025	A6T25	TSJ25
017A-2	35	600	JJS-35	JLLS035	A6T35	TSJ35
024A-2	40	600	JJS-40	JLLS040	A6T40	TSJ40
031A-2	60	600	JJS-60	JLLS060	A6T60	TSJ60
046A-2	100	600	JJS-100	JLLS100	A6T100	TSJ100
3-phase $U_n = 480$ V						
02A1-4	6	600	JJS-6	JLLS006	A6T6	TJS6
03A0-4	6	600	JJS-6	JLLS006	A6T6	TJS6
03A5-4	10	600	JJS-10	JLLS010	A6T10	TJS10
04A8-4	10	600	JJS-10	JLLS010	A6T10	TJS10
06A0-4	20	600	JJS-20	JLLS020	A6T20	TJS20
07A6-4	20	600	JJS-20	JLLS020	A6T20	TJS20
011A-4	25	600	JJS-25	JLLS025	A6T25	TJS25
014A-4	35	600	JJS-35	JLLS035	A6T35	TJS35
021A-4	40	600	JJS-40	JLLS040	A6T40	TJS40
027A-4	60	600	JJS-60	JLLS060	A6T60	TJS60
034A-4	80	600	JJS-80	JLLS080	A6T80	TJS80
042A-4	100	600	JJS-100	JLLS100	A6T100	TJS100

UL (NEC) type ACS480-04-...	Fuse		UL 248-8 Fast Acting Class J Fuses			
	Max. current	Voltage rating	Bussmann	Littelfuse	Mersen / Ferraz Shawmut	Edison
	A	V				
3-phase $U_n = 230$ V						
02A3-2	6	600	JKS-6	JLS6	A4J6	JFL6
03A5-2	10	600	JKS-10	JLS10	A4J10	JFL10
04A6-2	10	600	JKS-10	JLS10	A4J10	JFL10
06A6-2	20	600	JKS-20	JLS20	A4J20	JFL20
07A5-2	20	600	JKS-20	JLS20	A4J20	JFL20
11A6-2	25	600	JKS-25	JLS25	A4J25	JFL25
017A-2	35	600	JKS-35	JLS35	A4J35	JFL35
024A-2	40	600	JKS-40	JLS40	A4J40	JFL40
031A-2	60	600	JKS-60	JLS60	A4J60	JFL60
046A-2	100	600	JKS-100	JLS100	A4J100	JFL100
3-phase $U_n = 480$ V						
02A1-4	6	600	JKS-6	JLS6	A4J6	JFL6
03A0-4	6	600	JKS-6	JLS6	A4J6	JFL6
03A5-4	10	600	JKS-10	JLS10	A4J10	JFL10
04A8-4	10	600	JKS-10	JLS10	A4J10	JFL10
06A0-4	20	600	JKS-20	JLS20	A4J20	JFL20
07A6-4	20	600	JKS-20	JLS20	A4J20	JFL20
011A-4	25	600	JKS-25	JLS25	A4J25	JFL25
014A-4	35	600	JKS-35	JLS35	A4J35	JFL35
021A-4	40	600	JKS-40	JLS40	A4J40	JFL40
027A-4	60	600	JKS-60	JLS60	A4J60	JFL60
034A-4	80	600	JKS-80	JLS80	A4J80	JFL80
042A-4	100	600	JKS-100	JLS100	A4J100	JFL100

UL (NEC) type ACS480-04-...	Fuse		UL 248-8 High Speed Class J Fuses			
	Max. current	Voltage rating	Bussmann	Littelfuse	Mersen / Ferraz Shawmut	Edison
	A	V				
3-phase $U_n = 230$ V						
02A3-2	6	600	DFJ-6	LDFJ006	HSJ6	JHL6
03A5-2	10	600	DFJ-10	LDFJ010	HSJ10	JHL10
04A6-2	10	600	DFJ-10	LDFJ010	HSJ10	JHL10
06A6-2	20	600	DFJ-20	LDFJ020	HSJ20	JHL20
07A5-2	20	600	DFJ-20	LDFJ020	HSJ20	JHL20
11A6-2	25	600	DFJ-25	LDFJ025	HSJ25	JHL25
017A-2	35	600	DFJ-35	LDFJ035	HSJ35	JHL35
024A-2	40	600	DFJ-40	LDFJ040	HSJ40	JHL40
031A-2	60	600	DFJ-60	LDFJ060	HSJ60	JHL60
046A-2	100	600	DFJ-100	LDFJ100	HSJ100	JHL100
3-phase $U_n = 480$ V						
02A1-4	6	600	DFJ-6	LDFJ006	HSJ6	JHL6
03A0-4	6	600	DFJ-6	LDFJ006	HSJ6	JHL6
03A5-4	10	600	DFJ-10	LDFJ010	HSJ10	JHL10
04A8-4	10	600	DFJ-10	LDFJ010	HSJ10	JHL10
06A0-4	20	600	DFJ-20	LDFJ020	HSJ20	JHL20
07A6-4	20	600	DFJ-20	LDFJ020	HSJ20	JHL20
011A-4	25	600	DFJ-25	LDFJ025	HSJ25	JHL25
014A-4	35	600	DFJ-35	LDFJ035	HSJ35	JHL35
021A-4	40	600	DFJ-40	LDFJ040	HSJ40	JHL40
027A-4	60	600	DFJ-60	LDFJ060	HSJ60	JHL60
034A-4	80	600	DFJ-80	LDFJ080	HSJ80	JHL80
042A-4	100	600	DFJ-100	LDFJ100	HSJ100	JHL100

UL (NEC) type ACS480-04-...	Fuse		UL 248-4 Class CC Fast Acting Fuses			
	Max. current	Voltage rating	Bussmann	Littelfuse	Mersen / Ferraz Shawmut	Edison
	A	V				
3-phase $U_n = 230$ V						
02A3-2	6	600	KTK-R-6	KLKR6	ATMR6	HCLR6
03A5-2	10	600	KTK-R-10	KLKR10	ATMR10	HCLR10
04A6-2	10	600	KTK-R-10	KLKR10	ATMR10	HCLR10
06A6-2	20	600	KTK-R-20	KLKR20	ATMR20	HCLR20
07A5-2	20	600	KTK-R-20	KLKR20	ATMR20	HCLR20
11A6-2	25	600	KTK-R-25	KLKR25	ATMR25	HCLR25
3-phase $U_n = 480$ V						
02A1-4	6	600	KTK-R-6	KLKR6	ATMR6	HCLR6
03A0-4	6	600	KTK-R-6	KLKR6	ATMR6	HCLR6
03A5-4	10	600	KTK-R-10	KLKR10	ATMR10	HCLR10
04A8-4	10	600	KTK-R-10	KLKR10	ATMR10	HCLR10
06A0-4	20	600	KTK-R-20	KLKR20	ATMR20	HCLR20
07A6-4	20	600	KTK-R-20	KLKR20	ATMR20	HCLR20
011A-4	25	600	KTK-R-25	KLKR25	ATMR25	HCLR25
UL (NEC) type ACS480-04-...	Fuse			UL 248-17 Class CF Fast Acting Cube Fuse		
	Max. current	Voltage rating		Bussmann		
	A	V				
3-phase $U_n = 230$ V						
02A3-2	6	600		FCF6RN		
03A5-2	10	600		FCF10RN		
04A6-2	10	600		FCF10RN		
06A6-2	20	600		FCF20RN		
07A5-2	20	600		FCF20RN		
11A6-2	25	600		FCF25RN		
017A-2	35	600		FCF35RN		
024A-2	40	600		FCF40RN		

UL (NEC) type ACS480-04-...	Fuse		UL 248-17 Class CF Fast Acting Cube Fuse
	Max. current	Voltage rating	Bussmann
	A	V	
031A-2	60	600	FCF60RN
046A-2	100	600	FCF100RN
3-phase $U_n = 480$ V			
02A1-4	6	600	FCF6RN
03A0-4	6	600	FCF6RN
03A5-4	10	600	FCF10RN
04A8-4	10	600	FCF10RN
06A0-4	20	600	FCF20RN
07A6-4	20	600	FCF20RN
011A-4	25	600	FCF25RN
014A-4	35	600	FCF25RN
021A-4	40	600	FCF40RN
027A-4	60	600	FCF60RN
034A-4	80	600	FCF80RN
042A-4	100	600	FCF100RN

Alternative short-circuit protection

■ Miniature circuit breakers (IEC)

Note: Miniature circuit breakers with or without fuses have not been evaluated for use as short-circuit protection in North American (UL) environments.

The protective characteristics of the circuit breakers depend on the type, construction and settings of the breakers. There are also limitations pertaining to the short-circuit capacity of the supply network. Your local ABB representative can help you in selecting the breaker type when the supply network characteristics are known.



WARNING!

Due to the inherent operating principle and construction of circuit breakers, independent of the manufacturer, hot ionized gases can escape from the breaker enclosure in case of a short-circuit. To ensure safe use, pay special attention to the installation and placement of the breakers. Obey the manufacturer's instructions.

You can use the circuit breakers specified by ABB. You can also use other circuit breakers with the drive if they provide the same electrical characteristics. ABB does not assume any liability whatsoever for the correct function and protection of the circuit breakers not specified by ABB. Furthermore, if the specifications given by ABB are not obeyed, the drive can experience problems the warranty does not cover.

IEC type ACS480- 04-...	Frame	Miniature circuit breaker	Network SCC ¹⁾
		ABB type	kA
1-phase $U_n = 230\text{ V}$			
02A4-1	R0	S 201P-B 10 NA	5
03A7-1	R0	S 201P-B 10 NA	5
04A8-1	R1	S 201P-B 16 NA	5
06A9-1	R1	S 201P-B 20 NA	5
07A8-1	R1	S 201P-B 25 NA	5
09A8-1	R2	S 201P-B 25 NA	5
12A2-1	R2	S 201P-B 32 NA	5
3-phase $U_n = 230\text{ V}$			
02A4-2	R1	S 203P-Z 6 NA	5
03A7-2	R1	S 203P-Z 8 NA	5
04A8-2	R1	S 203P-Z 10 NA	5
06A9-2	R1	S 203P-Z 16 NA	5
07A8-2	R1	S 203P-Z 16 NA	5
09A8-2	R1	S 203P-Z 25 NA	5
12A2-2	R2	S 203P-Z 25 NA	5
17A5-2	R3	S 203P-Z 32 NA	5
25A0-2	R3	S 203P-Z 50 NA	5
032A-2	R4	S 203P-Z 63 NA	5

IEC type ACS480- 04-...	Frame	Miniature circuit breaker	Network SCC ¹⁾
		ABB type	kA
048A-2	R4	Contact ABB	5
3-phase $U_n = 400$ V			
02A7-4	R1	S 203P-B 6	5
03A4-4	R1	S 203P-B 6	5
04A1-4	R1	S 203P-B 8	5
05A7-4	R1	S 203P-B 10	5
07A3-4	R1	S 203P-B 16	5
09A5-4	R1	S 203P-B 16	5
12A7-4	R2	S 203P-B 25	5
018A-4	R3	S 203P-B 32	5
026A-4	R3	S 203P-B 50	5
033A-4	R4	S 203P-B 63	5
039A-4	R4	S 803S-B 80	5
046A-4	R4	S 803S-B 100	5
050A-4	R4	S 803S-B 100	5

¹⁾ Maximum permitted rated conditional short-circuit current (IEC 61800-5-1) of the electrical power network.

■ Miniature circuit breakers (UL)

ACS480 drives are suitable for use on a circuit capable of delivering not more than 10 kA symmetrical amperes (RMS) at 240 or 480Y/277 V maximum, when protected by appropriate circuit breakers in the tables below. Additional fuse protection is not required by UL when using circuit breakers herein. Circuit breakers are not required to be in the same enclosure as the drive.

ACS480- 04-...	Frame	Miniature circuit breaker	Minimum enclosure volume ^{1) 2)}
		ABB type	in ³
1-phase $U_n = 230$ V			
02A4-1	R0	SU202M-C10	1850
03A7-1	R0	SU202M-C10	1850
04A8-1	R1	SU202M-C20	1850
06A9-1	R1	SU202M-C20	1850

ACS480-04-...	Frame	Miniature circuit breaker	Minimum enclosure volume ^{1) 2)}
		ABB type	in ³
07A8-1	R1	SU202M-C20	1850
09A8-1	R2	SU202M-C32	1850
12A2-1	R2	SU202M-C32	1850
3-phase $U_n = 230$ V			
02A4-2	R1	SU203M-C16	1850
03A7-2	R1	SU203M-C16	1850
04A8-2	R1	SU203M-C16	1850
06A9-2	R1	SU203M-C16	1850
07A8-2	R1	SU203M-C25	1850
09A8-2	R1	SU203M-C25	1850
12A2-2	R2	SU203M-C25	1850
17A5-2	R3	SU203M-C50	1850
25A0-2	R3	SU203M-C50	1850
032A-2	R4	-	-
048A-2	R4	-	-
3-phase $U_n = 400$ V			
02A7-4	R1	SU203M-C10	1850
03A4-4	R1	SU203M-C10	1850
04A1-4	R1	SU203M-C10	1850
05A7-4	R1	SU203M-C10	1850
07A3-4	R1	SU203M-C16	1850
09A5-4	R1	SU203M-C16	1850
12A7-4	R2	SU203M-C25	1850
018A-4	R3	SU203M-C50	1850
026A-4	R3	SU203M-C50	1850
033A-4	R4	-	-
039A-4	R4	-	-
046A-4	R4	-	-

¹⁾ Drives that have an Minimum Enclosure Volume listed must be mounted in an enclosure \geq Minimum Enclosure Volume specified in this table.

2) When multiple drives that have an Enclosure Minimum Volume specified are installed in the same enclosure, minimum volume of the enclosure is determined by largest Enclosure Minimum Volume of the drives to be placed in the enclosure, plus the volume(s) of each additional drive.

■ **Manual self-protected combination motor controller – Type E USA (UL (NEC))**

You can use the ABB Type E manual motor protectors (MMP) MS132 & S1-M3-25, MS165-xx and MS5100-100 as an alternative to the recommended fuses as a means of branch circuit protection. This is in accordance with the National Electrical Code (NEC). When the correct ABB Type E manual motor protector is selected from the table and used for branch circuit protection, the drive is suitable for use in a circuit capable of delivering no more than 65 kA rms symmetrical amperes at the maximum rated voltage of the drive. See the table below for the appropriate MMP types and minimum enclosure volume of IP20 / UL open type drive mounted in an enclosure.

If you use a manual motor protector for the branch circuit protection of the drive, install the drive into a metal enclosure.

Note: The UL Listing of drive and MMP combinations applies only to drives that are mounted in appropriately sized metal enclosures that are capable of containing any drive component failure. Wall-mounted drives with UL Type 1 kits (optional) are not covered by the UL combination listing of drives with MMPs.



WARNING!

Use fuses for the short-circuit protection of a wall-mounted drive with the UL Type 1 kit (optional). Serious injury, fire, or damage to equipment can result from the use of MMPs instead of fuses.

UL (NEC) type ACS480-04-....	Frame	MMP type 1) 2) 3)	Minimum enclosure volume 4)	
			dm ³	in ³
1-phase $U_n = 230\text{ V}$				
02A3-1	R0	MS132-6.3 & S1-M3-25	30.3	1850
03A5-1	R0	MS132-10 & S1-M3-25	30.3	1850
04A6-1	R1	MS165-16	30.3	1850
06A6-1	R1	MS165-16	30.3	1850
07A4-1	R1	MS165-20	30.3	1850
09A3-1	R2	MS165-25	30.3	1850
11A6-1	R2	MS165-32	30.3	1850
3-phase $U_n = 230\text{ V}$				
02A3-2	R1	MS132-6.3 & S1-M3-25	30.3	1850
03A5-2	R1	MS132-10 & S1-M3-25	30.3	1850

UL (NEC) type ACS480-04-....	Frame	MMP type ^{1) 2) 3)}	Minimum enclosure volume ⁴⁾	
			dm ³	in ³
04A6-2	R1	MS132-10 & S1-M3-25	30.3	1850
06A6-2	R1	MS165-16	30.3	1850
07A5-2	R1	MS165-16	30.3	1850
11A6-2	R2	MS165-20	30.3	1850
017A-2	R3	MS165-32	30.3	1850
024A-2	R3	MS165-42	30.3	1850
031A-2	R4	MS165-54	75.0	4577
046A-2	R4	MS5100-100 / MS165-80	75.0	4577
3-phase $U_n = 480$ V				
02A1-4	R1	MS132-6.3 & S1-M3-25 ⁵⁾	30.3	1850
03A0-4	R1	MS132-6.3 & S1-M3-25 ⁵⁾	30.3	1850
03A5-4	R1	MS132-10 & S1-M3-25 ⁵⁾	30.3	1850
04A8-4	R1	MS132-10 & S1-M3-25 ⁵⁾	30.3	1850
06A0-4	R1	MS165-16	30.3	1850
07A6-4	R1	MS165-16	30.3	1850
011A-4	R2	MS165-20	30.3	1850
014A-4	R3	MS165-32	30.3	1850
021A-4	R3	MS165-42	30.3	1850
027A-4	R4	MS165-54	75.0	4577
034A-4	R4	MS165-65	75.0	4577
042A-4	R4	MS5100-100 / MS165-80	75.0	4577

- 1) All manual motor protectors listed are Type E self-protected up to 65 kA, except MS165-80 which is Type E self-protected up to 50 kA. See the ABB manual motor starter catalog (ISBC100214C0201) for complete technical data on the ABB Type E manual motor protectors. In order for these manual motor protectors to be used for branch circuit protection, they must be UL listed Type E manual motor protectors, otherwise they can be used only as an At Motor Disconnect. "At Motor Disconnect" is a disconnect just ahead of the motor on the load side of the panel.
- 2) 480Y/277 V wye systems only: Short-circuit protective devices with slash voltage ratings (e.g. 480Y/277 V AC) can be applied only in solidly grounded networks where the voltage from line-to-ground does not exceed the lower of the two ratings (e.g. 277 V AC), and the voltage from line-to-line does not exceed the higher of the two ratings (e.g. 480 V AC).
- 3) Manual motor protectors may require adjusting the trip limit from the factory setting at or above the drive input Amps to avoid nuisance tripping. If the manual motor protector is set to the maximum current trip level and nuisance tripping is occurring, select the next size MMP. (MS132-10 is the highest size in the MS132 frame size to meet Type E at 65 kA; the next size up is MS165-16.)
- 4) For all drives, the enclosure must be sized to accommodate the specific thermal considerations of the application as well as provide free space for cooling. Refer to the technical data. For UL only: The minimum enclosure volume is specified in the UL listing when applied with the ABB Type E MMP shown in the table. Fuses must be used for wall-mounted drives installed with a UL Type 1 kit.

5) Requires the use of the S1-M3-25 line side feeder terminal with the manual motor protector to meet Type E self-protection class.

Dimensions and weights

Frame	Dimensions and weights (IP20 / UL open type)															
	H1		H2		H3		W		D		M1		M2		Weight	
	mm	in	mm	in	mm	in	mm	in	mm	in	mm	in	mm	in	kg	lb
R0	205	8.1	223	8.8	170	6.7	73	2.9	208	8.2	50	1.97	191	7.52	1.7	3.6
R1	205	8.1	223	8.8	170	6.7	73	2.9	208	8.2	50	1.97	191	7.52	1.7	3.6
R2	205	8.1	223	8.8	170	6.7	97	3.8	208	8.2	75	2.95	191	7.52	2.2	4.9
R3	205	8.1	220	8.7	170	6.7	172	6.8	208	8.2	148	5.83	191	7.52	2.5	5.5
R4	205	8.1	240	9.5	170	6.7	262	10.3	213	8.4	234	9.21	191	7.52	5.6	12.4

Frame	Dimensions and weights (UL Type 1 kit installed)															
	H1		H2		H3		W		D		M1		M2		Weight	
	mm	in	mm	in	mm	in	mm	in	mm	in	mm	in	mm	in	kg	lb
R0	205	8.1	285	11.3	247	9.8	73	2.9	208	8.2	50	1.97	191	7.52	2.1	4.6
R1	205	8.1	293	11.6	247	9.8	73	2.9	208	8.2	50	1.97	191	7.52	2.1	4.6
R2	205	8.1	293	11.6	247	9.8	111	4.4	208	8.2	75	2.95	191	7.52	2.7	6.0
R3	205	8.1	329	13.0	261	10.3	186	7.4	208	8.2	148	5.83	191	7.52	3.2	7.1
R4	205	8.1	391	15.4	312	12.3	284	11.2	213	8.4	234	9.21	191	7.52	6.9	15.1

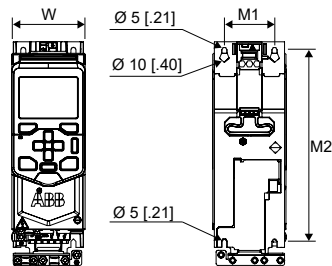
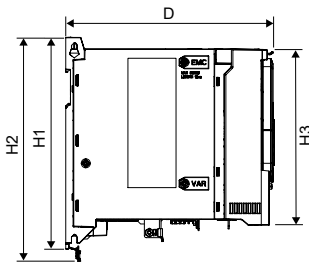

- H1 Height back
- H2 Height
- H3 Height front
- W Width

- D Depth
- M1 Mounting hole distance
- M2 Mounting hole distance

Free space requirements

Frame	Free space requirement					
	Above ¹⁾		Below		Sides	
	mm	in	mm	in	mm	in
All	75	3	75	3	0	0

¹⁾ Drives with the optional UL Type 1 kit: 50 mm (2 in), measured from the top of the hood.

Losses, cooling data and noise

Drives with frame size R0 have natural convection cooling. Drives with frame size R1...R4 have a cooling fan. The air flow direction is from bottom to top.

IEC type ACS480-04-...	Typical power loss ¹⁾		Air flow		Noise	Frame size
	W	BTU/h	m ³ /h	CFM	dB(A)	
1-phase $U_n = 230\text{ V}$						
02A4-1	33	113	-	-	< 30	R0
03A7-1	49	167	-	-	< 30	R0
04A8-1	67	229	57	33	63	R1
06A9-1	93	317	57	33	63	R1
07A8-1	106	362	57	33	63	R1
09A8-1	92	314	63	37	59	R2
12A2-1	115	392	63	37	59	R2
3-phase $U_n = 230\text{ V}$						
02A4-2	39	133	57	33	63	R1
03A7-2	57	194	57	33	63	R1
04A8-2	72	246	57	33	63	R1
06A9-2	111	379	57	33	63	R1
07A8-2	105	358	57	33	63	R1
09A8-2	140	478	57	33	63	R1
12A2-2	149	508	63	37	59	R2

IEC type ACS480-04-...	Typical power loss ¹⁾		Air flow		Noise	Frame size
	W	BTU/h	m ³ /h	CFM	dB(A)	
17A5-2	265	904	128	75	66	R3
25A0-2	398	1358	128	75	66	R3
032A-2	350	1194	150	88	69	R4
048A-2	561	1914	150	88	69	R4
3-phase $U_n = 400$ V						
02A7-4	44	150	57	33	63	R1
03A4-4	55	188	57	33	63	R1
04A1-4	62	212	57	33	63	R1
05A7-4	91	311	57	33	63	R1
07A3-4	100	341	57	33	63	R1
09A5-4	140	478	57	33	63	R1
12A7-4	165	563	63	37	59	R2
018A-4	259	884	128	75	66	R3
026A-4	390	1331	128	75	66	R3
033A-4	396	1351	150	88	69	R4
039A-4	497	1696	150	88	69	R4
046A-4	582	1986	150	88	69	R4
050A-4	672	2293	150	88	69	R4

¹⁾ Typical drive losses when it operates at 90% of the motor nominal frequency and 100% of the drive nominal output current.

UL (NEC) type ACS480-04-...	Typical power loss ¹⁾		Air flow		Noise	Frame size
	W	BTU/h	m ³ /h	CFM	dB(A)	
1-phase $U_n = 230$ V						
02A3-1	33	113	-	-	< 30	R0
03A5-1	49	167	-	-	< 30	R0
04A6-1	67	229	57	33	63	R1
06A6-1	93	317	57	33	63	R1
07A4-1	106	362	57	33	63	R1
09A3-1	92	314	63	37	59	R2
11A6-1	115	392	63	37	59	R2

UL (NEC) type ACS480-04...	Typical power loss ¹⁾		Air flow		Noise	Frame size
	W	BTU/h	m ³ /h	CFM	dB(A)	
3-phase $U_n = 230\text{ V}$						
02A3-2	39	133	57	33	63	R1
03A5-2	57	194	57	33	63	R1
04A6-2	72	246	57	33	63	R1
06A6-2	111	379	57	33	63	R1
07A5-2	105	358	57	33	63	R1
11A6-2	149	508	63	37	59	R2
017A-2	265	904	128	75	66	R3
024A-2	398	1358	128	75	66	R3
031A-2	350	1194	150	88	69	R4
046A-2	561	1914	150	88	69	R4
3-phase $U_n = 480\text{ V}$						
02A1-4	44	150	57	33	63	R1
03A0-4	55	188	57	33	63	R1
03A5-4	62	212	57	33	63	R1
04A8-4	91	311	57	33	63	R1
06A0-4	100	341	57	33	63	R1
07A6-4	140	478	57	33	63	R1
011A-4	165	563	63	37	59	R2
014A-4	259	884	128	75	66	R3
021A-4	390	1331	128	75	66	R3
027A-4	396	1351	150	88	69	R4
034A-4	497	1696	150	88	69	R4
042A-4	672	2293	150	88	69	R4

¹⁾ Typical drive losses when it operates at 90% of the motor nominal frequency and 100% of the drive nominal output current.

Typical power cable sizes

The tables in this section give the typical power cable and conductor sizes for use at the nominal drive current.

Note: IEC/EN 61800-5-1 requires two separate PE (ground) conductors for a fixed connection, if the cross-sectional area of the PE conductor is less than 10 mm² Cu.

IEC type ACS480- 04-...	Cable size, Cu (mm ²) ¹⁾	Conductor size, Cu (AWG)	Frame
1-phase $U_n = 230$ V			
02A4-1	3×1.5 + 1.5	14	R0
03A7-1	3×1.5 + 1.5	14	R0
04A8-1	3×1.5 + 1.5	14	R1
06A9-1	3×1.5 + 1.5	14	R1
07A8-1	3×1.5 + 1.5	14	R1
09A8-1	3×2.5 + 2.5	14	R2
12A2-1	3×2.5 + 2.5	14	R2
3-phase $U_n = 230$ V			
02A4-2	3×1.5 + 1.5	14	R1
03A7-2	3×1.5 + 1.5	14	R1
04A8-2	3×1.5 + 1.5	14	R1
06A9-2	3×1.5 + 1.5	14	R1
07A8-2	3×1.5 + 1.5	14	R1
09A8-2	3×2.5 + 2.5	14	R1
12A2-2	3×2.5 + 2.5	14	R2
17A5-2	3×6 + 6	10	R3
25A0-2	3×6 + 6	10	R3
032A-2	3×10 + 10	8	R4
048A-2	3×25 + 16	4	R4
3-phase $U_n = 400$ V			
02A7-4	3×1.5 + 1.5	14	R1
03A4-4	3×1.5 + 1.5	14	R1
04A1-4	3×1.5 + 1.5	14	R1
05A7-4	3×1.5 + 1.5	14	R1
07A3-4	3×1.5 + 1.5	14	R1
09A5-4	3×2.5 + 2.5	14	R1
12A7-4	3×2.5 + 2.5	14	R2

IEC type ACS480- 04-...	Cable size, Cu (mm ²) ¹⁾	Conductor size, Cu (AWG)	Frame
018A-4	3×6 + 6	10	R3
026A-4	3×6 + 6	10	R3
033A-4	3×10 + 10	8	R4
039A-4	3×16 + 16	6	R4
046A-4	3×25 + 16	4	R4
050A-4	3×25 + 16	4	R4

¹⁾ Symmetrical, shielded, three-phase copper cable.

UL (NEC) type ACS480- 04-...	Cable size, Cu (mm ²) ¹⁾	Conductor size, Cu (AWG)	Frame
1-phase $U_n = 230$ V			
02A3-1	3×1.5 + 1.5	14	R0
03A5-1	3×1.5 + 1.5	14	R0
04A6-1	3×1.5 + 1.5	14	R1
06A6-1	3×1.5 + 1.5	14	R1
07A4-1	3×1.5 + 1.5	14	R1
09A3-1	3×2.5 + 2.5	14	R2
11A6-1	3×2.5 + 2.5	14	R2
3-phase $U_n = 230$ V			
02A3-2	3×1.5 + 1.5	14	R1
03A5-2	3×1.5 + 1.5	14	R1
04A6-2	3×1.5 + 1.5	14	R1
06A6-2	3×1.5 + 1.5	14	R1
07A5-2	3×1.5 + 1.5	14	R1
11A6-2	3×2.5 + 2.5	14	R2
017A-2	3×6 + 6	14	R3
024A-2	3×6 + 6	10	R3
031A-2	3×10 + 10	8	R4
046A-2	3×25 + 16	4	R4

UL (NEC) type ACS480-04-...	Cable size, Cu (mm ²) ¹⁾	Conductor size, Cu (AWG)	Frame
3-phase $U_n = 480$ V			
02A1-4	3×1.5 + 1.5	14	R1
03A0-4	3×1.5 + 1.5	14	R1
03A5-4	3×1.5 + 1.5	14	R1
04A8-4	3×1.5 + 1.5	14	R1
06A0-4	3×1.5 + 1.5	14	R1
07A6-4	3×2.5 + 2.5	14	R1
011A-4	3×2.5 + 2.5	14	R2
014A-4	3×6 + 6	10	R3
021A-4	3×6 + 6	10	R3
027A-4	3×10 + 10	8	R4
034A-4	3×16 + 16	6	R4
042A-4	3×25 + 16	4	R4

1) Symmetrical, shielded, three-phase copper cable.

Terminal data for the power cables

IEC type ACS480-04-...	L1, L2, L3, T1/U, T2/V, T3/W, R-, R+/UDC+			PE		
	Minimum (solid/stranded)	Maximum (solid/stranded)	Tightening torque	Minimum (solid/stranded)	Maximum (solid/stranded)	Tightening torque
	mm ²	mm ²	N·m	mm ²	mm ²	N·m
1-phase $U_n = 230$ V						
02A4-1	0.5/0.5	4/2.5	0.5...0.6	4/2.5	6/4	1.2
03A7-1	0.5/0.5	4/2.5	0.5...0.6	4/2.5	6/4	1.2
04A8-1	0.5/0.5	4/2.5	0.5...0.6	4/2.5	6/4	1.2
06A9-1	0.5/0.5	4/2.5	0.5...0.6	4/2.5	6/4	1.2
07A8-1	0.5/0.5	4/2.5	0.5...0.6	4/2.5	6/4	1.2
09A8-1	0.5/0.5	4/2.5	0.5...0.6	4/2.5	6/4	1.2
12A2-1	0.5/0.5	4/2.5	0.5...0.6	4/2.5	6/4	1.2

IEC type ACS480- 04-...	L1, L2, L3, T1/U, T2/V, T3/W, R-, R+/ UDC+			PE		
	Minimum (sol- id/stran- ded)	Maximum (sol- id/stran- ded)	Tightening torque	Minimum (sol- id/stran- ded)	Maximum (sol- id/stran- ded)	Tightening torque
	mm ²	mm ²	N·m	mm ²	mm ²	N·m
3-phase $U_n = 230\text{ V}$						
02A4-2	0.5/0.5	4/2.5	0.5...0.6	4/2.5	6/4	1.2
03A7-2	0.5/0.5	4/2.5	0.5...0.6	4/2.5	6/4	1.2
04A8-2	0.5/0.5	4/2.5	0.5...0.6	4/2.5	6/4	1.2
06A9-2	0.5/0.5	4/2.5	0.5...0.6	4/2.5	6/4	1.2
07A8-2	0.5/0.5	4/2.5	0.5...0.6	4/2.5	6/4	1.2
09A8-2	0.5/0.5	4/2.5	0.5...0.6	4/2.5	6/4	1.2
12A2-2	0.5/0.5	4/2.5	0.5...0.6	4/2.5	6/4	1.2
17A5-2	0.5/0.5	10/6	1.2...1.5	4/2.5	6/4	1.2
25A0-2	0.5/0.5	10/6	1.2...1.5	4/2.5	6/4	1.2
032A-2	0.5/0.5	25/16	2.5...3.7	10/6	25/16	2.9
048A-2	0.5/0.5	25/16	2.5...3.7	10/6	25/16	2.9
3-phase $U_n = 400\text{ V}$						
02A7-4	0.5/0.5	4/2.5	0.5...0.6	4/2.5	6/4	1.2
03A4-4	0.5/0.5	4/2.5	0.5...0.6	4/2.5	6/4	1.2
04A1-4	0.5/0.5	4/2.5	0.5...0.6	4/2.5	6/4	1.2
05A7-4	0.5/0.5	4/2.5	0.5...0.6	4/2.5	6/4	1.2
07A3-4	0.5/0.5	4/2.5	0.5...0.6	4/2.5	6/4	1.2
09A5-4	0.5/0.5	4/2.5	0.5...0.6	4/2.5	6/4	1.2
12A7-4	0.5/0.5	4/2.5	0.5...0.6	4/2.5	6/4	1.2
018A-4	0.5/0.5	10/6	1.2...1.5	4/2.5	6/4	1.2
026A-4	0.5/0.5	10/6	1.2...1.5	4/2.5	6/4	1.2
033A-4	0.5/0.5	25/16	2.5...3.7	10/6	25/16	2.9
039A-4	0.5/0.5	25/16	2.5...3.7	10/6	25/16	2.9
046A-4	0.5/0.5	25/16	2.5...3.7	10/6	25/16	2.9
050A-4	0.5/0.5	25/16	2.5...3.7	10/6	25/16	2.9

UL (NEC) type ACS480- 04-...	L1, L2, L3, T1/U, T2/V, T3/W, R-, R+/ UDC+			PE		
	Minimum	Maximum	Tightening torque	Minimum	Maximum	Tightening torque
	AWG	AWG	lbf-in	AWG	AWG	lbf-in
1-phase $U_n = 230\text{ V}$						
02A3-1	18	10	5	12	10	10.6
03A5-1	18	10	5	12	10	10.6
04A6-1	18	10	5	12	10	10.6
06A6-1	18	10	5	12	10	10.6
07A4-1	18	10	5	12	10	10.6
09A3-1	18	10	5	12	10	10.6
11A6-1	18	10	5	12	10	10.6
3-phase $U_n = 230\text{ V}$						
02A3-2	18	10	5	12	10	10.6
03A5-2	18	10	5	12	10	10.6
04A6-2	18	10	5	12	10	10.6
06A6-2	18	10	5	12	10	10.6
07A5-2	18	10	5	12	10	10.6
11A6-2	18	10	5	12	10	10.6
017A-2	18	6	11...13	12	10	10.6
024A-2	18	6	11...13	12	10	10.6
031A-2	18	2	22...32	8	4	25.7
046A-2	18	2	22...32	8	4	25.7
3-phase $U_n = 480\text{ V}$						
02A1-4	18	10	5	12	10	10.6
03A0-4	18	10	5	12	10	10.6
03A5-4	18	10	5	12	10	10.6
04A8-4	18	10	5	12	10	10.6
06A0-4	18	10	5	12	10	10.6
07A6-4	18	10	5	12	10	10.6
011A-4	18	10	5	12	10	10.6
014A-4	18	6	11...13	12	10	10.6

UL (NEC) type ACS480- 04-...	L1, L2, L3, T1/U, T2/V, T3/W, R-, R+/ UDC+			PE		
	Minimum	Maximum	Tightening torque	Minimum	Maximum	Tightening torque
	AWG	AWG	lbf·in	AWG	AWG	lbf·in
021A-4	18	6	11...13	12	10	10.6
027A-4	18	2	22...32	8	4	25.7
034A-4	18	2	22...32	8	4	25.7
042A-4	18	2	22...32	8	4	25.7

Note:

- The minimum specified wire size does not necessarily have sufficient current carrying capacity at maximum load.
- The terminals do not accept a conductor that is one size larger than the maximum specified wire size.
- The maximum number of conductors per terminal is 1.

Terminal data for the control cables

This table shows the control cable terminal data of the standard drive variant, that is, the base unit with RIIO-01 I/O & EIA-485 module.

Wire size		Torque	
mm ²	AWG	N·m	lbf·in
0.14...1.5	26...16	0.5...0.6	4.4...5.3

Electrical power network specification

Voltage (U1)	Input voltage range: ACS480-04-xxxx-1 drives: 1-phase 200 ... 240 V AC -15% ... +10%. ACS480-04-xxxx-2 drives: 3-phase 200 ... 240 V AC -15% ... +10%. ACS480-04-xxxx-4 drives: 3-phase 380 ... 480 V AC -15% ... +10%.
Network type	Public low voltage networks. Symmetrically grounded TN-S system, IT (ungrounded), corner-grounded delta. Consult ABB before connecting to other systems (for example, TT, or midpoint grounded delta).

Rated conditional short-circuit current I_{CC} (IEC 61800-5-1)	65 kA when protected by fuses given in the fuse tables.												
Maximum prospective short-circuit current rating (SCCR) (UL 61800-5-1, CSA C22.2 No. 274-13)	US and Canada: The drive is suitable for use on a circuit capable of delivering not more than 100 kA symmetrical amperes (rms) at 480 V maximum when protected by fuses given in the fuse table.												
Harmonic current limits in public network (IEC/EN 61000-3-2, IEC/EN 61000-3-12)	Refer to Compliance with the harmonic current limits in a public network (IEC/EN 61000 3-2, IEC/EN 61000-3-12) (page 176).												
Input choke	<p>Refer to Input chokes (page 203) for general guidelines on the use of the choke.</p> <p>Use an input choke, if the short-circuit capacity of the network at the drive terminals is more than specified in this table:</p> <table border="1" data-bbox="360 655 1034 823"> <thead> <tr> <th>Input voltage</th> <th>R0, R1, R2</th> <th>R3, R4</th> </tr> </thead> <tbody> <tr> <td>1-phase 200 ... 240 V</td> <td>>1.5 kA</td> <td>-</td> </tr> <tr> <td>3-phase 200 ... 240 V</td> <td>>5.0 kA</td> <td>>7.5 kA</td> </tr> <tr> <td>3-phase 380 ... 480 V</td> <td>>5.0 kA</td> <td>>10 kA</td> </tr> </tbody> </table> <p>Suitable chokes are given in this manual. You can use one choke for several drives if the short-circuit capacity at the drive terminals is decreased to the value in the table.</p>	Input voltage	R0, R1, R2	R3, R4	1-phase 200 ... 240 V	>1.5 kA	-	3-phase 200 ... 240 V	>5.0 kA	>7.5 kA	3-phase 380 ... 480 V	>5.0 kA	>10 kA
Input voltage	R0, R1, R2	R3, R4											
1-phase 200 ... 240 V	>1.5 kA	-											
3-phase 200 ... 240 V	>5.0 kA	>7.5 kA											
3-phase 380 ... 480 V	>5.0 kA	>10 kA											
Frequency (f1)	47 ... 63 Hz, maximum rate of change 2%/s												
Imbalance	Max. $\pm 3\%$ of nominal phase to phase input voltage												
Fundamental power factor (cos phi)	0.98 (at nominal load)												

Motor connection data

Motor type	Asynchronous AC induction motors, permanent magnet synchronous motors or ABB synchronous reluctance motors (SynRM motors)
Voltage (U2)	0 ... U1, 3-phase symmetrical
Short-circuit protection (IEC 61800-5-1, UL 61800-5-1)	The motor output is short-circuit proof by IEC 61800-5-1 and UL 61800-5-1.
Frequency (f2)	0 ... 500 Hz
Frequency resolution	0.01 Hz

Current	See the electrical ratings given in this manual.
Switching frequency	2, 4, 8, or 12 kHz

■ **Motor cable length**

Operational functionality and motor cable length

The drive is designed to operate with optimum performance with these maximum motor cable lengths. The values are valid for 4 kHz switching frequency.

Note: Conducted and radiated emissions of these motor cable lengths do not comply with the EMC requirements of IEC/EN 61800-3.

Frame	Maximum motor cable length	
	m	ft
Standard drive, without external options		
R0...R4	100	328

Note: In multimotor systems, the calculated sum of all motor cable lengths must not exceed the maximum motor cable length given in the table.

EMC compatibility and motor cable length

To comply with the EMC requirements of IEC/EN 61800-3, do not exceed these maximum motor cable lengths. The values are valid for 4 kHz switching frequency.

Frame	Maximum motor cable length, 4 kHz					
	C1 ¹⁾		C2		C3	
	m	ft	m	ft	m	ft
With internal EMC filter						
1-phase 200 ... 240 V						
R0	-	-	10	33	10	33
R1	-	-	10	33	10	33
R2	-	-	10	33	10	33
3-phase 380 ... 480 V						
R1	-	-	10	33	30	98
R2	-	-	10	33	20	66
R3	-	-	10	33	30	98
R4	-	-	10	33	30	98

Frame	Maximum motor cable length, 4 kHz					
	C1 ¹⁾		C2		C3	
	m	ft	m	ft	m	ft
With optional external EMC filter						
1-phase 200 ... 240 V						
R0	10	33	10	33	10	33
R1	10	33	10	33	10	33
R2	-	-	-	-	-	-
3-phase 200 ... 240 V						
R1	-	-	20	66	20	66
R2	-	-	20	66	20	66
R3	-	-	20	66	20	66
R4	-	-	20	66	20	66
3-phase 380 ... 480 V						
R1	40	131	40	131	40	131
R2	40	131	40	131	40	131
R3	40	131	40	131	40	131
R4	30	98	30	98	30	98

1) Category C1 with conducted emissions only. Radiated emissions are not compatible when measured with the standard emission measurement setup and must be measured on cabinet and machine installations for each case.

Brake resistor connection data

Short-circuit protection (IEC 61800-5-1, IEC 60439-1, UL 61800-5-1)	The brake resistor output is conditionally short-circuit proof by IEC/EN 61800-5-1 and UL 61800-5-1. Rated conditional short-circuit current is as defined in IEC 60439-1.
--	---

Control connection data

The data is valid for the standard drive variant (base unit equipped with the RIIO-01 I/O & EIA-485 module).

Analog inputs (AI1, AI2)	Voltage signal, single-ended	0 ... 10 V DC (10% overrange, 11 V DC max.) $R_{in} = 221.6 \text{ kohm}$
	Current signal, single-ended	0 ... 20 mA (10% overrange, 22 mA max.) $R_{in} = 137 \text{ ohm}$
	Inaccuracy	$\leq 1.0\%$, of full scale
	Overvoltage protection	up to 30 V DC
	Potentiometer reference value	10 V DC $\pm 1\%$, max. load current 10 mA
Analog output (AO1, AO2)	Current output mode	0 ... 20 mA (10% overrange, 22 mA max.) into 500 ohm load (AO2 only supports output current)
	Voltage output mode	0 ... 10 V DC (10% overrange, 11 V DC max.) into 200 kohm minimum load (resistive)
	Inaccuracy	$\leq 2\%$, of full scale
Auxiliary power output or input (+24V, DGND)	As output	+24 V DC $\pm 10\%$, max. 250 mA (from base unit and/or RIIO-01 module)
	As input (optional BAPO-01 module required)	+24 V DC $\pm 10\%$, max. 1000 mA (incl. internal fan load)
Digital inputs (DI1...DI6)	Voltage	12 ... 24 V DC (int. or ext. supply) max. 30 V DC.
	Type	PNP and NPN
	Input impedance	$R_{in} = 2 \text{ kohm}$
DI5 (digital or frequency input)	Voltage	12 ... 24 V DC (int. or ext. supply) max. 30 V DC.
	Type	PNP and NPN
	Input impedance	$R_{in} = 2 \text{ kohm}$
	Max. frequency	10 ... 16 kHz
Relay output (RO1, RO2, RO3)	Type	1 form C (NO + NC)
	Max. switching voltage	250 V AC / 30 V DC
	Max. switching current	2 A (non inductive)

Safe torque off (STO) interface (SGND, IN1, IN2, OUT1)	Refer to The Safe torque off function (page 225)
EIA-485 embedded fieldbus (A+, B-, DGND)	Connector pitch 5 mm, maximum wire size 2.5 mm ² (14 AWG) Physical layer: RS-485 Cable type: Shielded twisted pair cable with twisted pair for data and a wire or pair for signal ground, nominal impedance 100 ... 165 ohm, for example Belden 9842 Transmission rate: 9.6 ... 115.2 kbit/s Termination by switch
Control panel - PC connection	USB Type A – Type Mini-B cable, maximum cable length 3 m (9.8 ft)

Energy efficiency data (ecodesign)

Energy efficiency data according to IEC 61800-9-2 is available from the ecodesign tool (<https://ecodesign.drivesmotors.abb.com/>).



Energy efficiency data is not provided for the 1~230 V drives. The drives with one phase input are not in the scope of the EU ecodesign requirements (Regulation EU/2019/1781) or the UK ecodesign requirements (Regulation SI 2021 No. 745).

Protection classes

Degree of protection (IEC/EN 60529)	IP20. The drive must be installed in a cabinet to fulfill the requirements for shielding from contact.
Enclosure types (UL 61800-5-1)	UL open type. For indoor use only. UL Type 1 kit is available as an option.
Overvoltage category (IEC 60664-1)	III
Protective classes (IEC/EN 61800-5-1)	I

Ambient conditions

Environmental limits for the drive are given below. The drive must be used in a heated indoor controlled environment.

Requirement	Operation installed for stationary use	Storage in the protective package	Transportation in the protective package
Installation site altitude	<p>230 V drives: 0 ... 2000 m (0 ... 6562 ft) above sea level (with output derating above 1000 m [3281 ft])</p> <p>400/480 V drives: 0 ... 4000 m (0 ... 13123 ft) above sea level (with output derating above 1000 m [3281 ft])</p> <p>See Output derating (page 135).</p>	-	-
Surrounding air temperature	<p>-10 ... +60 °C (14 ... 140 °F). For frame R0, -10 ... +50 °C (14 ... 122 °F).</p> <p>If the temperature is more than 50 °C (122 °F), output derating is necessary. See Output derating (page 135).</p> <p>No frost permitted.</p>	-40 ... +70 °C ±2% (-40 ... +158 °F ±2%)	-40 ... +70 °C ±2% (-40 ... +158 °F ±2%)
Relative humidity	5 ... 95%	Max. 95%	Max. 95%
Contamination levels (IEC 60721-3-x)	IEC 60721-3-3: 2002	IEC 60721-3-1: 1997	IEC 60721-3-2: 1997
- Chemical gases	Class 3C2	Class 1C2	Class 2C2
- Solid particles	Class 3S2. No conductive dust permitted.	Class 1S3. (packing must support this, otherwise 1S2)	Class 2S2
Pollution degree (IEC/EN 61800-5-1)	Pollution degree 2	-	-

Requirement	Operation installed for stationary use	Storage in the protective package	Transportation in the protective package
Sinusoidal vibration (IEC 60068-2-6, Test Fc 2007-12)	frequency 10 ... 150 Hz; amplitude ± 0.075 mm (0.003 in), 10 ... 57,56 Hz; constant peak acceleration 10 m/s^2 (33 ft/s^2), 57,56 ... 150 Hz; sweep: 1 oct/min; 10 sweep cycles in each axis with STO active; uncertainty $\pm 5.0\%$; normal mounting	-	-
Shock /(IEC 60068-2-27, ISTA 1A)	Not permitted	According to ISTA 1A. Max. 100 m/s^2 (330 ft/s^2), 11 ms.	According to ISTA 1A. Max. 100 m/s^2 (330 ft/s^2), 11 ms.
Free fall	-	76 cm (30 in)	76 cm (30 in)

Storage conditions

Store the drive in humidity controlled enclosed environments. Keep the drive in its package.

Materials

■ Drive

Refer to [ACx480 drives recycling instructions and environmental information \(3AXD50000102372 \[English\]\)](#).

■ Drive package

- Cardboard
- Molded pulp
- PE (suspension film package, plastic bag).

■ Package materials for options, accessories and spare parts

- Cardboard
- Kraft paper

- PP (straps)
- PE (film, bubble wrap)
- Plywood, wood (only for heavy components).

Materials vary according to the item type, size and shape. Typical package consists of a cardboard box with paper filling or bubble wrap. ESD-safe packing materials are used for printed circuit boards and similar items.

■ **Materials of manuals**

Printed product manuals are made of recyclable paper. Product manuals are available on the Internet.

Disposal

The main parts of the drive can be recycled to preserve natural resources and energy. Product parts and materials should be dismantled and separated.

Generally all metals, such as steel, aluminum, copper and its alloys, and precious metals can be recycled as material. Plastics, rubber, cardboard and other packaging material can be used in energy recovery.

Printed circuit boards and DC capacitors need selective treatment according to IEC 62635 guidelines.

To aid recycling, most plastic parts are marked with an appropriate identification code. In addition, components containing substances of very high concern (SVHCs) are listed in European Chemicals Agency's SCIP database. SCIP is the database for information on Substances of Concern In articles as such or in complex objects (Products) established under the Waste Framework Directive (2008/98/EC). For further information, contact your local ABB distributor or consult European Chemicals Agency's SCIP database to find out which SVHCs are used in the drive, and to find out where those components are located.

Contact your local ABB distributor for further information on environmental aspects. End of life treatment must follow international and national regulations.

For more information on ABB end of life services, refer to new.abb.com/service/end-of-life-services.

Applicable standards



The drive complies with the following standards:







EN ISO 13849-1:2015	Safety of machinery – Safety related parts of the control systems – Part 1: general principles for design
EN ISO 13849-2:2012	Safety of machinery – Safety-related parts of the control systems – Part 2: Validation

EN 60204-1:2006 + A1:2009 + AC:2010	Safety of machinery. Electrical equipment of machines. Part 1: General requirements. Provisions for compliance: The final assembler of the machine is responsible for installing <ul style="list-style-type: none"> • an emergency-stop device • a supply disconnecting device
EN 62061:2005 + AC:2010 + A1:2013 + A2:2015	Safety of machinery – Functional safety of safety-related electrical, electronic and programmable electronic control systems
EN 61800-3:2004 + A1:2012 IEC 61800-3:2004 + A1:2011	Adjustable speed electrical power drive systems. Part 3: EMC requirements and specific test methods
IEC/EN 61800-5-1:2007+AMD1:2016 EN 61800-5-1:2007+A1:2017+A11:2021	Adjustable speed electrical power drive systems – Part 5-1: Safety requirements – Electrical, thermal and energy
IEC 61800-9-2:2017	Adjustable speed electrical power drive systems – Part 9-2: Ecodesign for power drive systems, motor starters, power electronics and their driven applications – Energy efficiency indicators for power drive systems and motor starters
ANSI/UL 61800-5-1:2015	UL Standard for adjustable speed electrical power drive systems – Part 5-1: Safety requirements – Electrical, thermal and energy
CSA C22.2 No. 274-17	Adjustable speed drives

Markings

The applicable markings are shown on the type designation label of the drive.

	CE mark Product complies with the applicable European Union legislation. For fulfilling the EMC requirements, see the additional information concerning the drive EMC compliance (IEC/EN 61800-3).
	UKCA (UK Conformity Assessed) mark Product complies with the applicable United Kingdom's legislation (Statutory Instruments). Marking is required for products being placed on the market in Great Britain (England, Wales and Scotland).
	TÜV Safety Approved mark (functional safety) Product contains Safe torque off and possibly other (optional) safety functions which are certified by TÜV according to the relevant functional safety standards. Applicable to drives and inverters; not applicable to supply, brake or DC/DC converter units or modules.

	<p>UL Listed mark for USA and Canada</p> <p>Product has been tested and evaluated against the relevant North American standards by the Underwriters Laboratories. Valid with rated voltages up to 600 V.</p>
	<p>RCM mark</p> <p>Product complies with Australian and New Zealand requirements specific to EMC, telecommunications and electrical safety. For fulfilling the EMC requirements, see the additional information concerning the drive EMC compliance (IEC/EN 61800-3).</p>
	<p>CMIM mark</p> <p>Product complies with Morocco's safety standard for marketing of toys and electrical products.</p>
	<p>EAC (Eurasian Conformity) mark</p> <p>Product complies with the technical regulations of the Eurasian Customs Union. EAC mark is required in Russia, Belarus and Kazakhstan.</p>
	<p>Electronic Information Products (EIP) symbol including an Environment Friendly Use Period (EFUP).</p> <p>Product is compliant with the People's Republic of China Electronic Industry Standard (SJ/T 11364-2014) about hazardous substances. The EFUP is 20 years. China RoHS II Declaration of Conformity is available from https://library.abb.com.</p>
	<p>WEEE mark</p> <p>At the end of life the product should enter the recycling system at an appropriate collection point and not placed in the normal waste stream.</p>
	<p>KC mark</p> <p>Product complies with Korean Registration of Broadcasting and Communications Equipment Clause 3, Article 58-2 of Radio Waves Act.</p>

■ **Compliance with the harmonic current limits in a public network (IEC/EN 61000 3-2, IEC/EN 61000-3-12)**

3-phase 230 V, 400 V or 480 V drive with the input choke

The drive complies with IEC 61000-3-12 provided that the short-circuit ratio $R_{s_{ce}}$ is greater than or equal to value 350 at the interface point between the user's supply and the public system. It is the responsibility of the installer or user of the equipment to ensure, by consultation with the distribution network operator if necessary, that the short-circuit ratio $R_{s_{ce}}$ is greater than or equal to 350.

The $R_{s_{ce}}$ value meets the requirement if the short-circuit power at the interface point between the user's supply and the public system is equal or bigger than the value S_{CS} calculated as follows:

$$S_{cs} = R_{s_{ce}} \times S_{eq} = 350 \times \sqrt{3} \times I_{1n} \times U_1$$

where:

- S_{CS} Minimum short-circuit power limit
- $R_{s_{ce}}$ Short-circuit ratio
- S_{eq} Equipment (drive) input power
- I_{1n} Drive nominal input current with the input choke
- U_1 Drive input voltage

3-phase 230 V, 400 V or 480 V drive without the input choke

Refer to [1-phase 230 V drive with or without the input choke \(page 177\)](#).

1-phase 230 V drive with or without the input choke

Do a harmonic current assessment for the whole system that the drive is part of, and make sure that the harmonic current limits are not exceeded at the interface point between the user's supply and the public system. Based on results, consider the use of the input choke with the drive. If the assessment is not possible, you can connect the drive to the public network if you have a permission from the network operator.

Always use the input choke if the short circuit capacity of the network at the drive input terminals exceeds the limit specified for the drive. Refer to [Input choke \(page 167\)](#) in section [Electrical power network specification \(page 166\)](#).

EMC compliance (IEC/EN 61800-3:2004 + A1:2012)

■ Definitions

EMC stands for Electromagnetic Compatibility. It is the ability of electrical/electronic equipment to operate without problems within an electromagnetic environment. Likewise, the equipment must not disturb or interfere with any other product or system within its locality.

First environment includes establishments connected to a low-voltage network which supplies buildings used for domestic purposes.

Second environment includes establishments connected to a network not supplying domestic premises.

Drive of category C1: drive of rated voltage less than 1000 V and intended for use in the first environment.

Drive of category C2: drive of rated voltage less than 1000 V and intended to be installed and started up only by a professional when used in the first environment.

Note: A professional is a person or organization having necessary skills in installing and/or starting up power drive systems, including their EMC aspects.

Drive of category C3: drive of rated voltage less than 1000 V and intended for use in the second environment and not intended for use in the first environment.

Drive of category C4: drive of rated voltage equal to or above 1000 V, or rated current equal to or above 400 A, or intended for use in complex systems in the second environment.

■ **Category C1**

The drive complies with the conducted emission limits of the standard with the following provisions:

1. The optional EMC filter is selected according to [External EMC filter](#), and the filter is installed as specified in the EMC filter manual.
2. The motor and control cables are selected as specified in this manual. The EMC recommendations are obeyed.
3. The maximum motor cable length does not exceed the specified maximum value. See [EMC compatibility and motor cable length \(page 168\)](#)
4. The drive is installed according to the instructions (IEC) given in this manual.

This product can cause radio-frequency inference. In a residential or domestic environment, supplementary mitigation measures may be required in addition to the requirements listed above for the CE compliance.

■ **Category C2**

This is applicable to drives with an internal EMC C2 filter. The filter is included in all drive types. But in UL (NEC) drive types the filter is disconnected at the factory. If necessary, the user can connect the filter.

The drive complies with the standard with the following provisions:

1. The motor and control cables are selected as specified in this manual. The EMC recommendations are obeyed.
2. The maximum motor cable length does not exceed the specified maximum. See [EMC compatibility and motor cable length \(page 168\)](#)
3. The drive is installed according to the instructions (IEC) given in this manual.

This product can cause radio-frequency inference. In a residential or domestic environment, supplementary mitigation measures may be required in addition to the requirements listed above for the CE compliance.



WARNING!

Do not install a drive with the internal EMC filter connected to a grounding system that the EMC filter is not compatible with (for example, an IT system). The supply network becomes connected to ground potential through the internal EMC filter capacitors, which can cause danger or damage to the drive.



WARNING!

To prevent radio-frequency interference, do not use a category C2 drive on a low-voltage public network that supplies domestic premises.

■ **Category C3**

The drive has an internal EMC C2 filter as standard. No EMC C3 filter for category C3 is available.

■ **Category C4**

If the provisions in category 2 or 3 are not met, the requirements of the standard can be met as follows:

1. It is ensured that no excessive emission is propagated to neighboring low-voltage networks. In some cases, the inherent suppression in transformers and cables is sufficient. If in doubt, the supply transformer with static screening between the primary and secondary windings can be used.

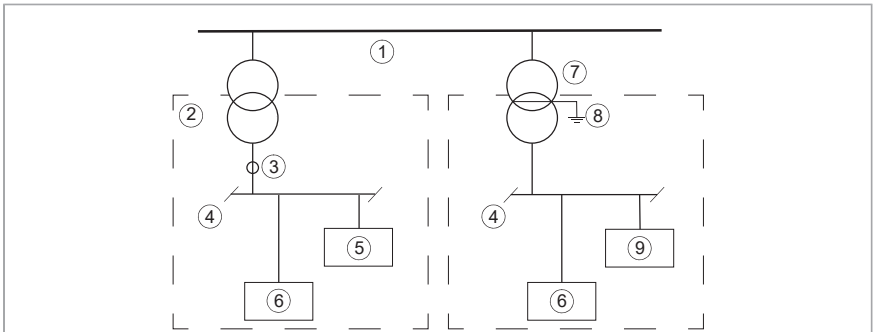

1	Medium voltage network
2	Neighboring network
3	Point of measurement
4	Low voltage
5	Equipment (victim)
6	Equipment

7	Supply transformer
8	Static screen
9	Drive

2. An EMC plan for preventing disturbances is drawn up for the installation. A template is available in [Technical guide No. 3 EMC compliant installation and configuration for a power drive system \(3AFE61348280 \[English\]\)](#).
3. The motor and control cables are selected as specified in this manual. For the best EMC performance, the EMC recommendations are obeyed.
4. The drive is installed according to the instructions given in this manual.



WARNING!

Do not install a drive with the internal EMC filter connected to a grounding system that the EMC filter is not compatible with (for example, an IT system). The supply network becomes connected to ground potential through the internal EMC filter capacitors, which can cause danger or damage to the drive.



WARNING!

To prevent radio-frequency interference, do not use a category C4 drive on a low-voltage public network that supplies domestic premises.

UL checklist



WARNING!

Operation of this drive requires detailed installation and operation instructions provided in the hardware and software manuals. The manuals are provided in electronic format in the drive package or on the Internet. Keep the manuals with the drive at all times. Hard copies of the manuals can be ordered through the manufacturer.

- Make sure that the drive type designation label includes the applicable marking.
 - **DANGER - Risk of electric shock.** After disconnecting the input power, always wait for 5 minutes to let the intermediate circuit capacitors discharge before you start working on the drive, motor or motor cable.
 - The drive is to be used in a heated, indoor controlled environment. The drive must be installed in clean air according to the enclosure classification. Cooling air must be clean, free from corrosive materials and electrically conductive dust.
 - The maximum surrounding air temperature is 50 °C at rated output current. The output current is derated for 50...60 °C in drives with frame size R1...R4.
-

- The drive is suitable for use in a circuit capable of delivering not more than 100000 rms symmetrical amperes, 480 V maximum (480 V drive types) or 240 V maximum (240 V drive types) when protected by the UL fuses given elsewhere in this chapter. The ampere ratings of the protections are based on fault tests done according to the appropriate UL standard.
- The drive is suitable for use on a circuit capable of delivering not more than 65000 rms symmetrical amperes, 480Y/277 V maximum (480 V drive types), when protected by a Type E combination motor controller specified by ABB.
- The cables located within the motor circuit must be rated for at least 75 °C in UL-compliant installations.
- The input cable must be protected with UL-rated fuses, or the ABB Type E manual motor protectors (MMP) listed in this manual. The fuses or the manual motor protectors provide branch circuit protection in accordance with the National Electrical Code (NEC) and Canadian Electrical Code. Obey also any other applicable local or provincial codes.

**WARNING!**

The opening of the branch-circuit protective device may be an indication that a fault current has been interrupted. To reduce the risk of fire or electric shock, current-carrying parts and other components of the device should be examined and replaced if damaged.

- The integral solid state short circuit protection of the drive does not provide branch circuit protection. Branch circuit protection must be provided in accordance with the National Electrical Code and any additional local codes.
- The drive provides motor overload protection. For adjustments, see the firmware manual.

Disclaimers

■ Generic disclaimer

The manufacturer shall have no obligation with respect to any product which (i) has been improperly repaired or altered; (ii) has been subjected to misuse, negligence or accident; (iii) has been used in a manner contrary to the manufacturer's instructions; or (iv) has failed as a result of ordinary wear and tear.



■ Cyber security disclaimer

This product is designed to be connected to and to communicate information and data via a network interface. It is Customer's sole responsibility to provide and continuously ensure a secure connection between the product and Customer network or any other network (as the case may be). Customer shall establish and maintain any appropriate measures (such as but not limited to the installation of firewalls, application of authentication measures, encryption of data, installation

of anti-virus programs, etc.) to protect the product, the network, its system and the interface against any kind of security breaches, unauthorized access, interference, intrusion, leakage and/or theft of data or information.

ABB and its affiliates are not liable for damages and/or losses related to such security breaches, any unauthorized access, interference, intrusion, leakage and/or theft of data or information.

Declarations of conformity

	<p>Link to Declaration of conformity according to EU Machinery Directive 2006/42/EC 3AXD10000594964</p>
	<p>Link to Declaration of conformity according to UK Supply of Machinery (Safety) Regulations 2008 3AXD10001329531</p>

11

Dimension drawings

Contents of this chapter

The chapter contains the dimension drawings of the drive. The dimensions are in millimeters and inches.

Frame R0

■ Frame R0 (front & side) - IP20 / UL open type

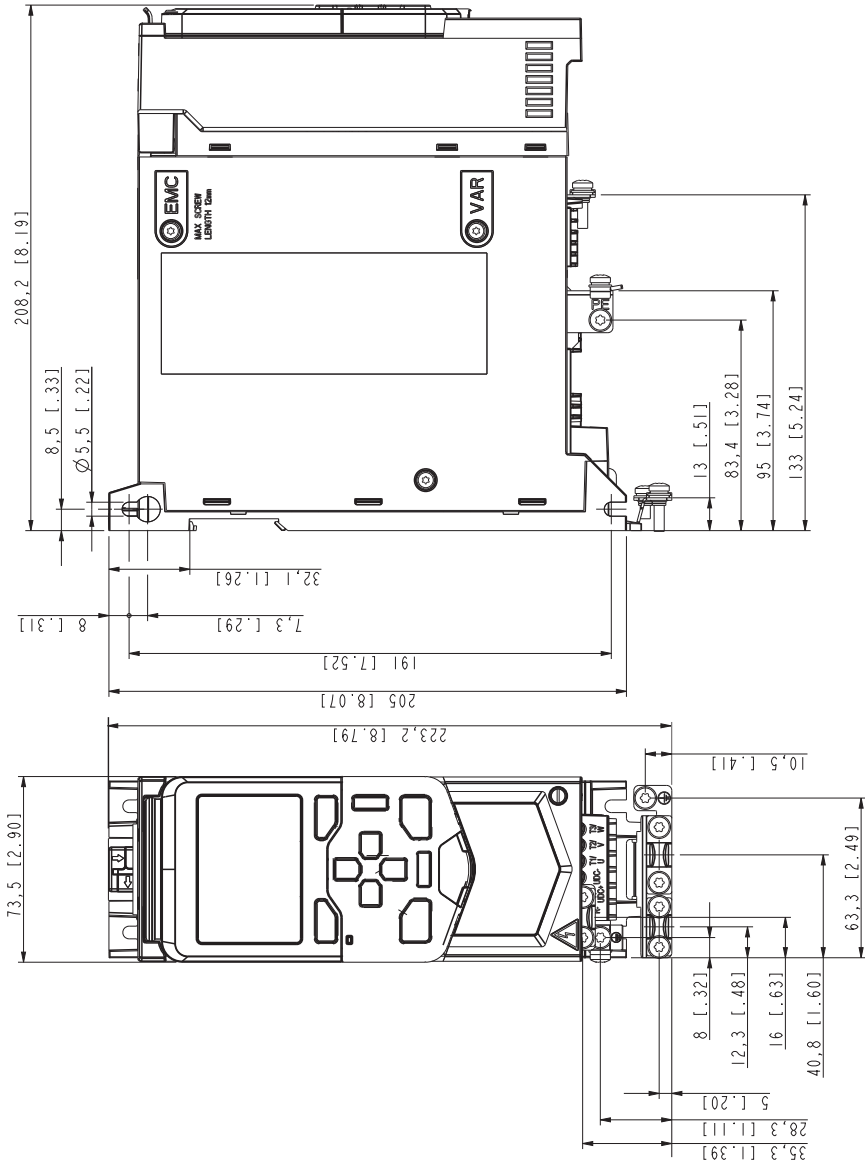

■ Frame R0 (bottom & rear) - IP20 / UL open type

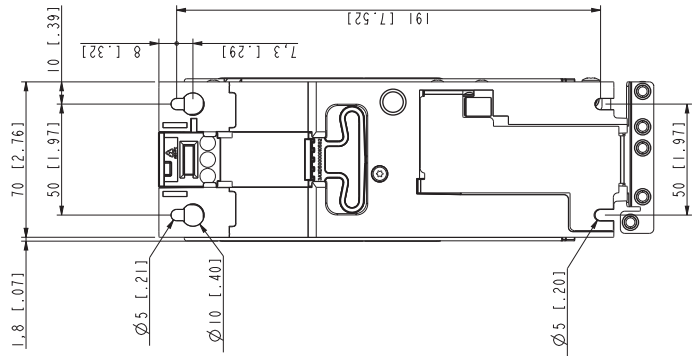
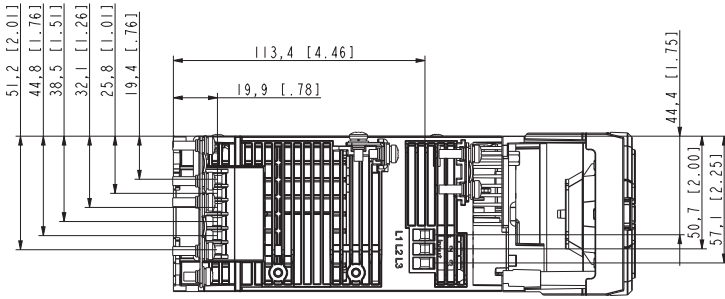

Frame R1

■ Frame R1 (front & side) - IP20 / UL open type

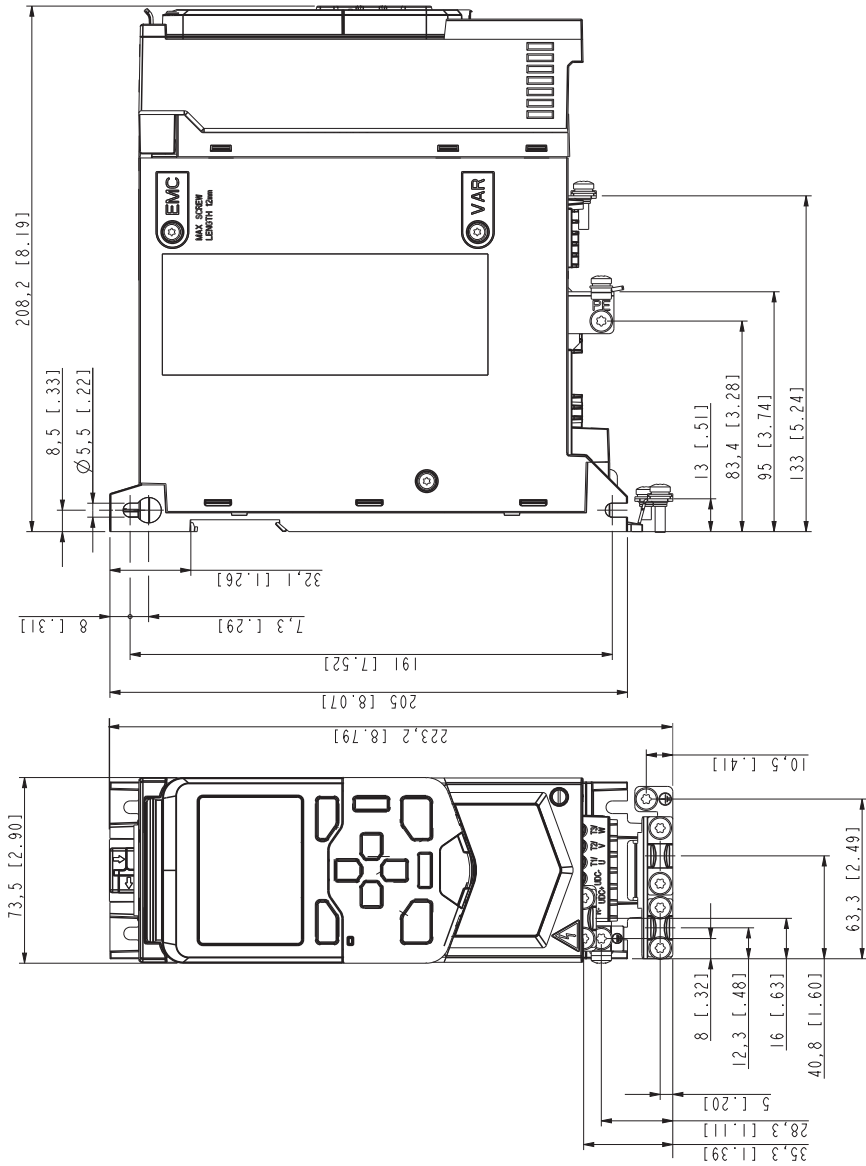

■ Frame R1 (bottom & rear) - IP20 / UL open type

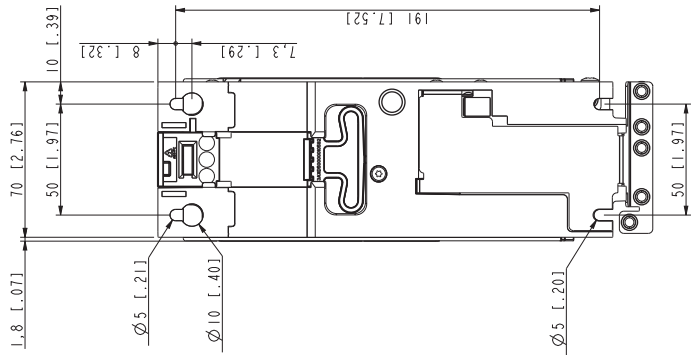
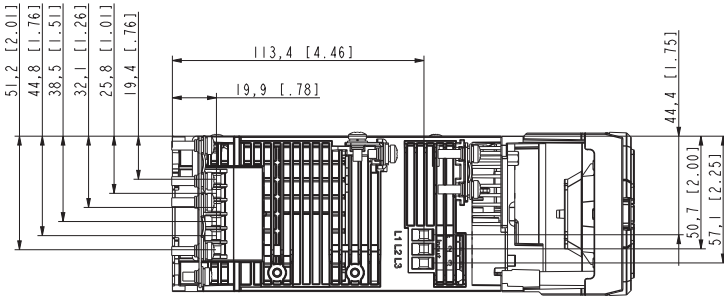

■ Frame R1 (front & side) - UL Type 1 kit installed

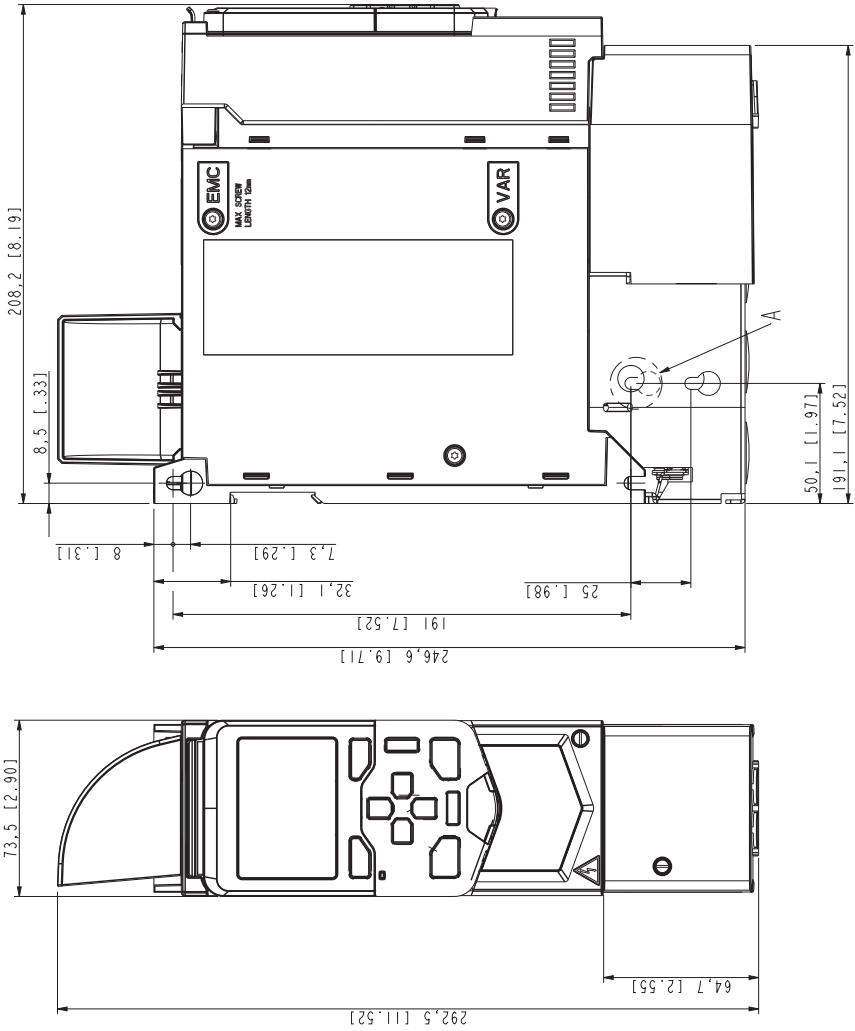

■ **Frame R1 (bottom & rear) - UL Type 1 kit installed**

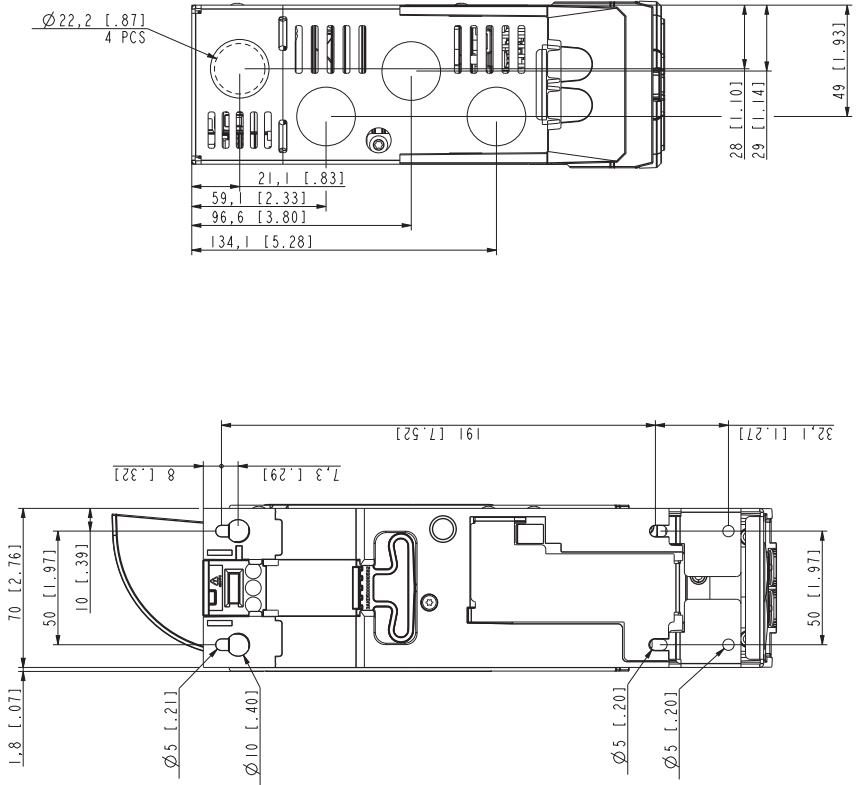

Frame R2

■ Frame R2 (front & side) - IP20 / UL open type

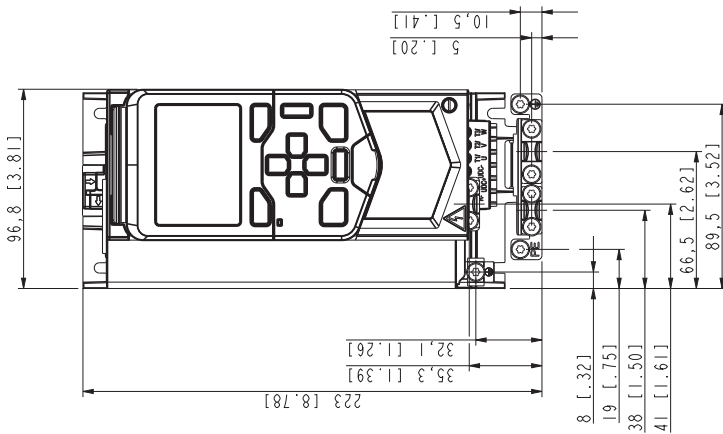
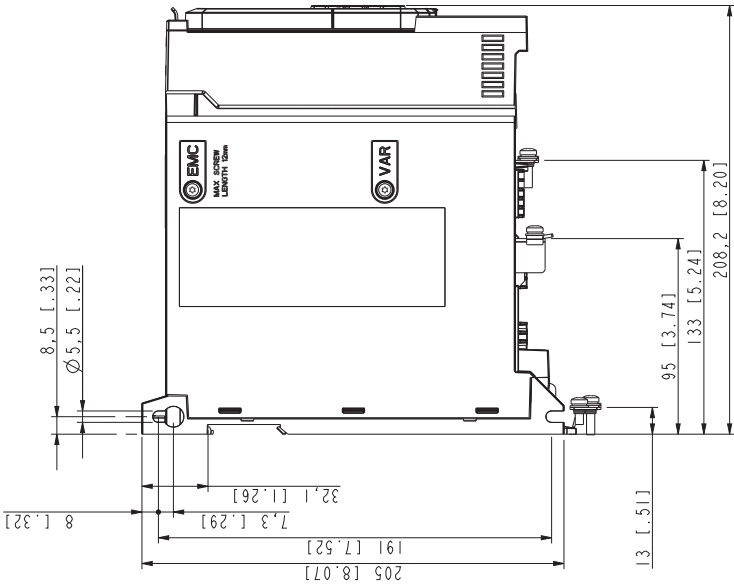

■ Frame R2 (front & side) - UL Type 1 kit installed

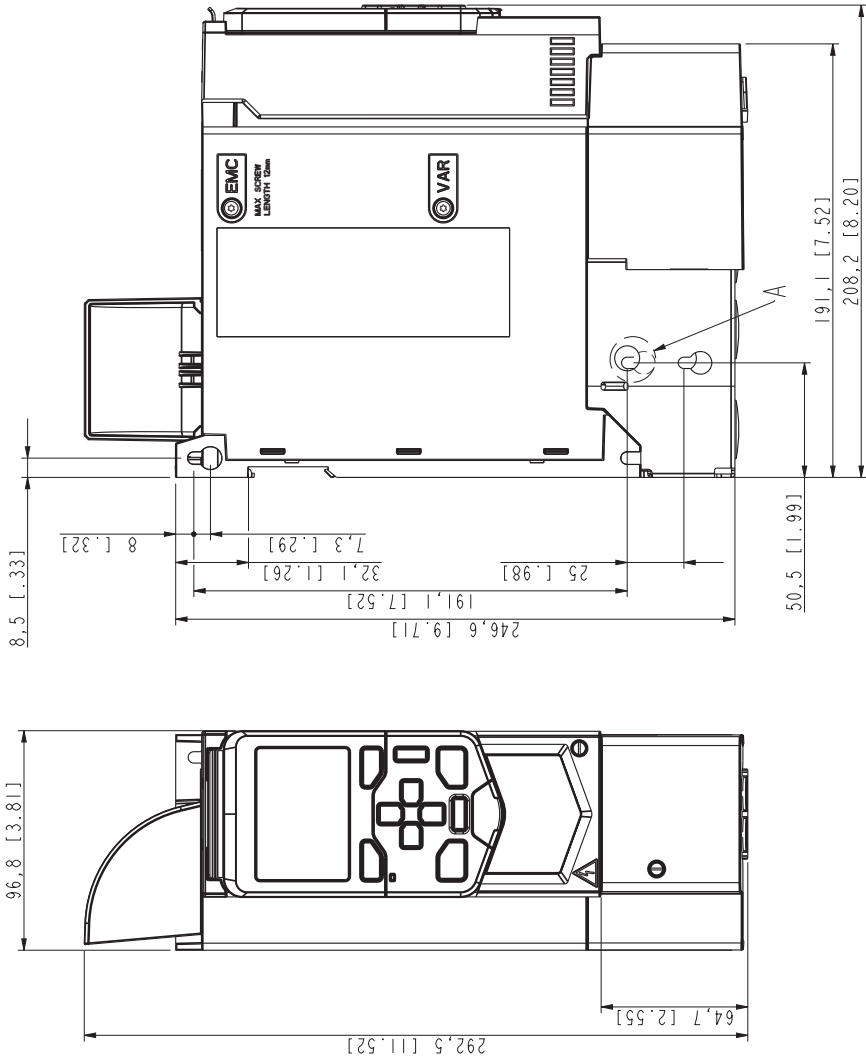

■ **Frame R2 (bottom & rear) - UL Type 1 kit installed**

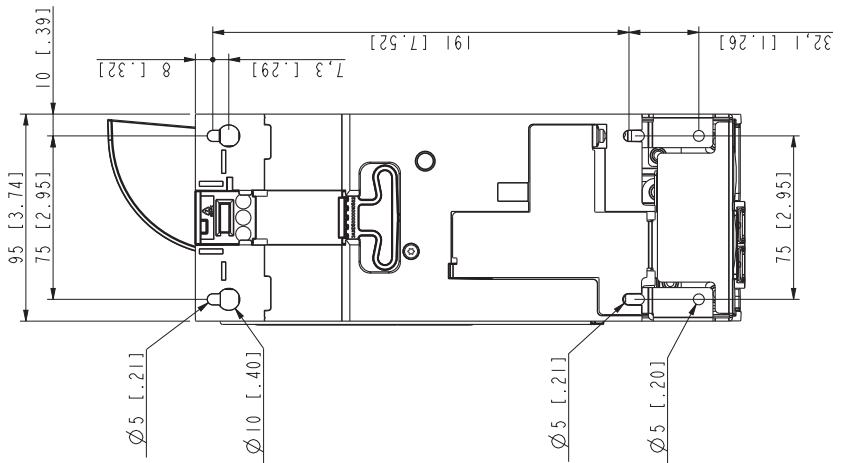
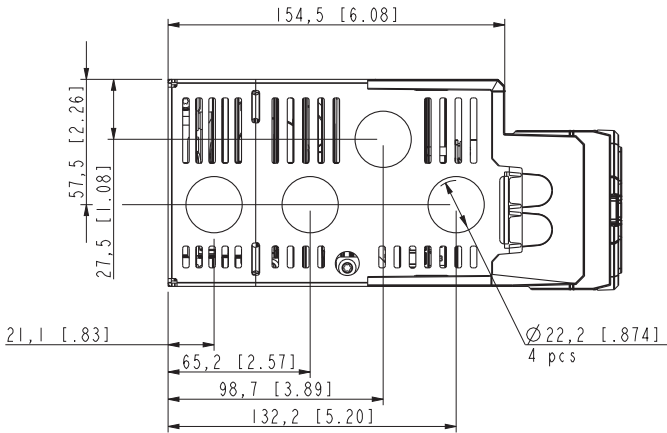

Frame R3

- Frame R3 (front & side) - IP20 / UL open type

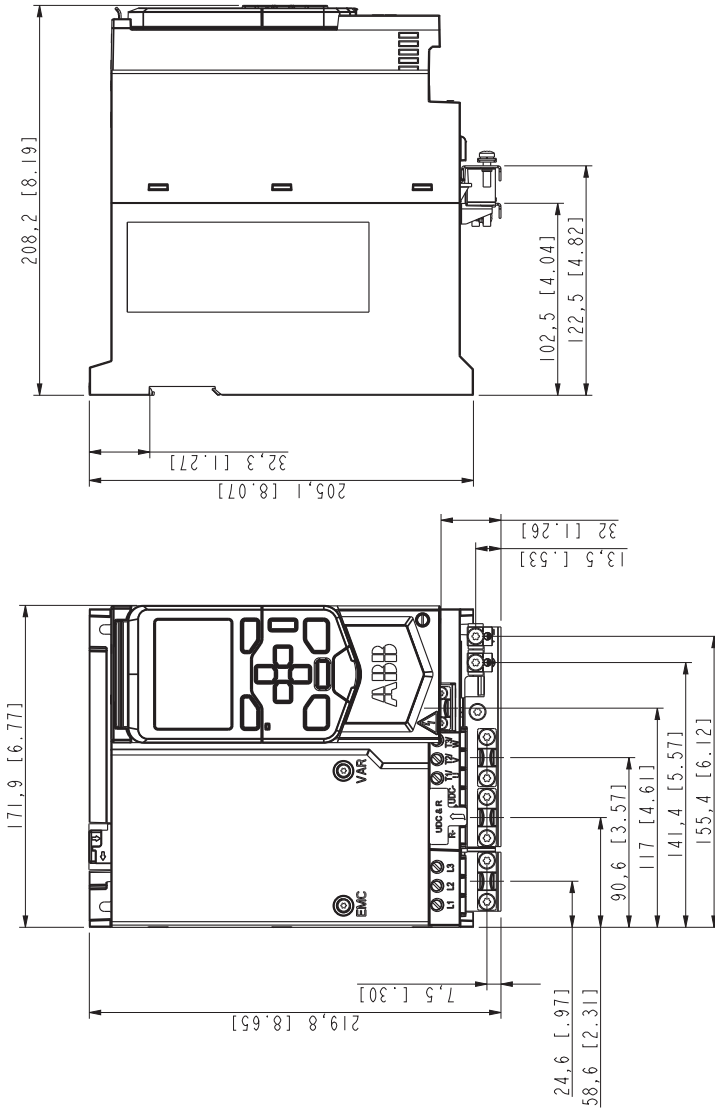

■ Frame R3 (bottom & rear) - IP20 / UL open type

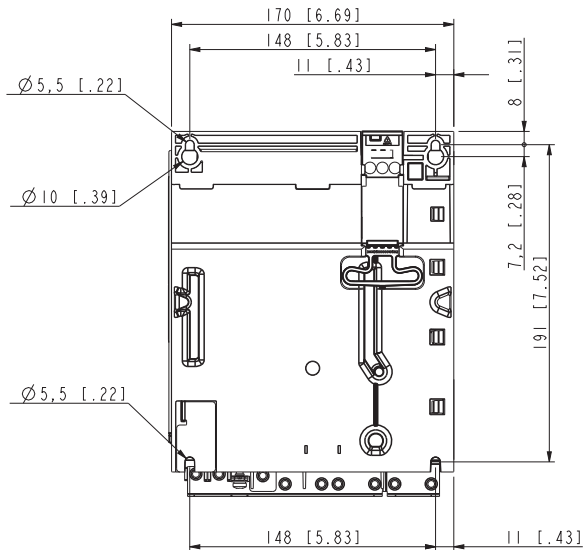
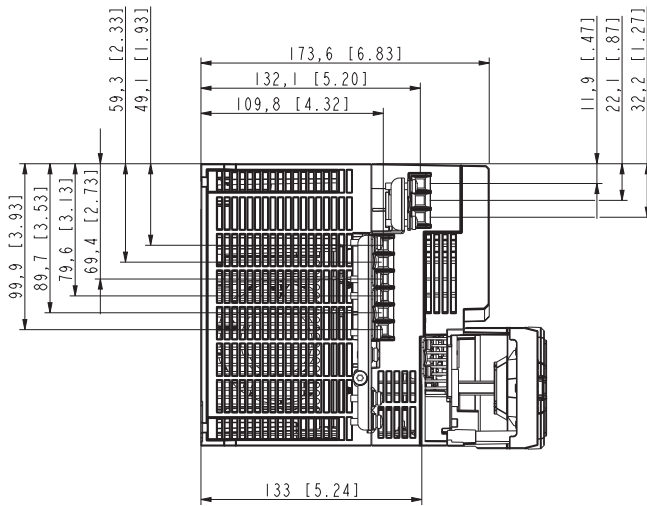

■ Frame R3 (front & side) - UL Type 1 kit installed

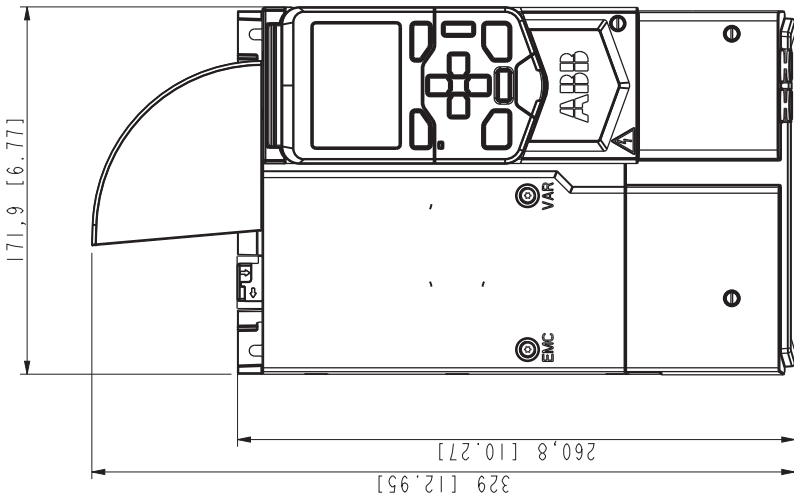
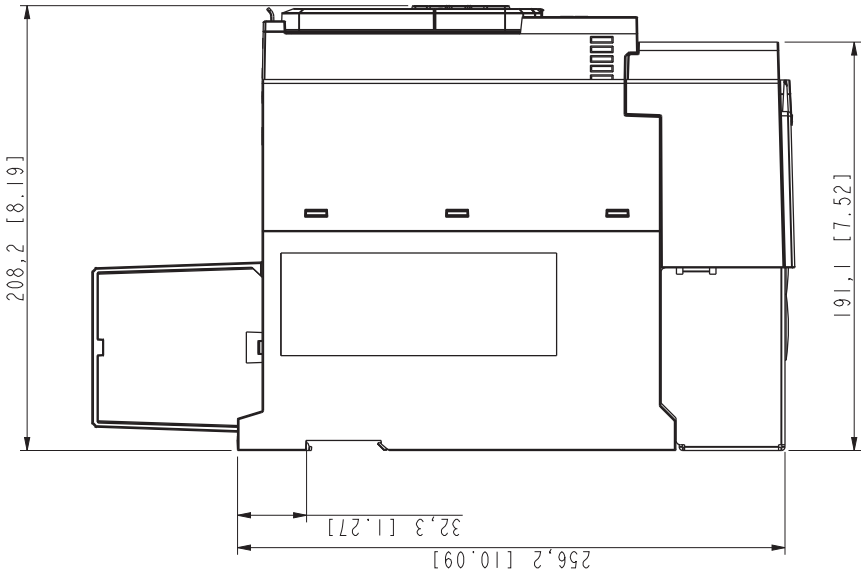

■ Frame R3 (bottom & rear) - UL Type 1 kit installed

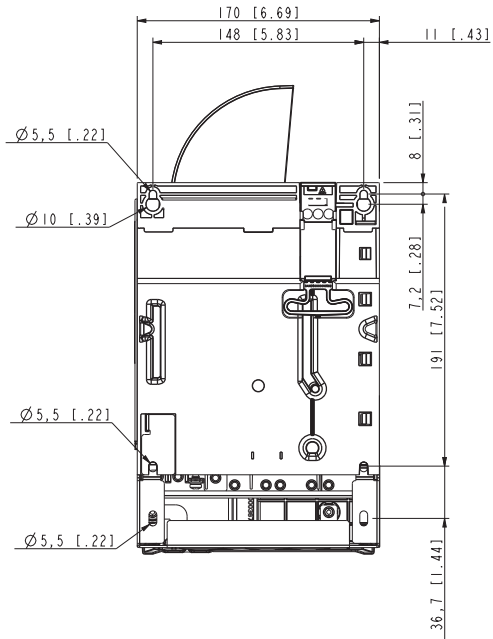
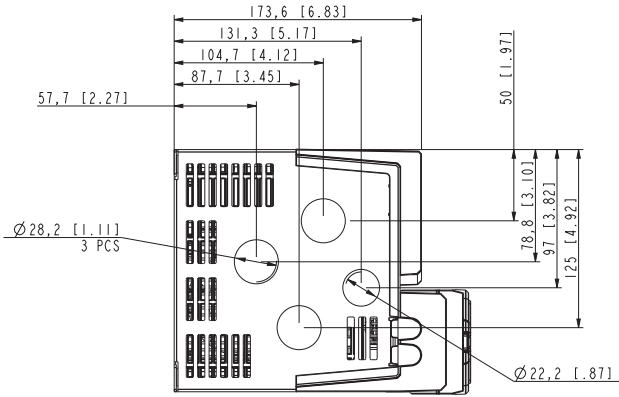

Frame R4

■ Frame R4 (front & side) - IP20 / UL open type

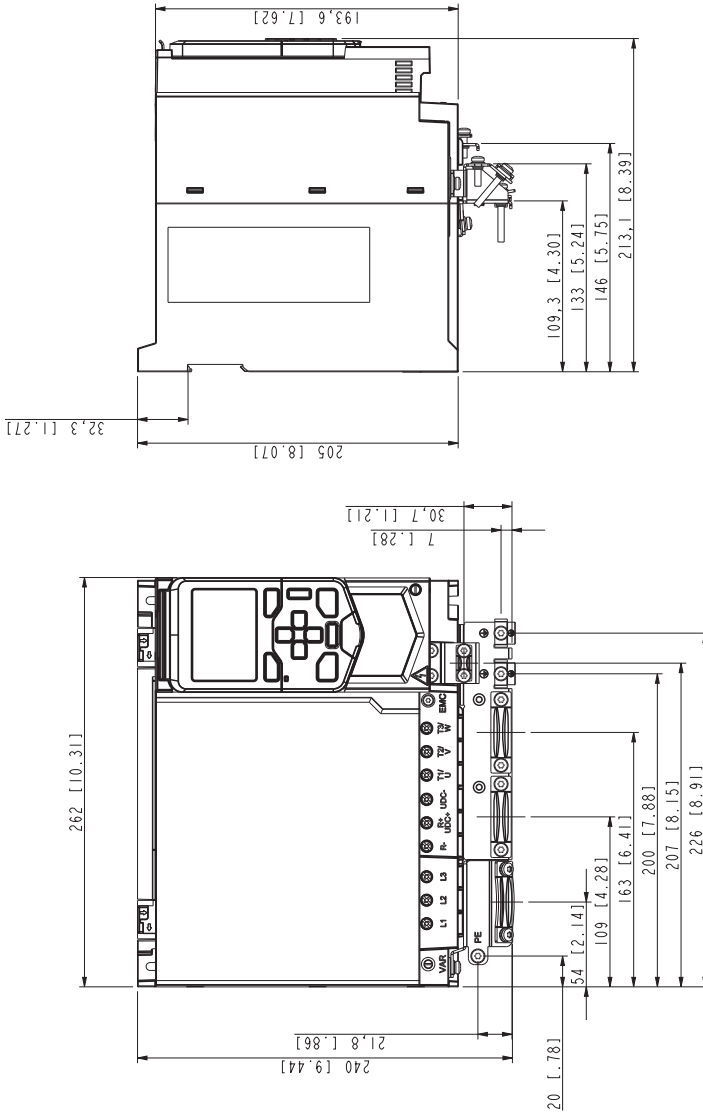

■ Frame R4 (bottom & rear) - IP20 / UL open type

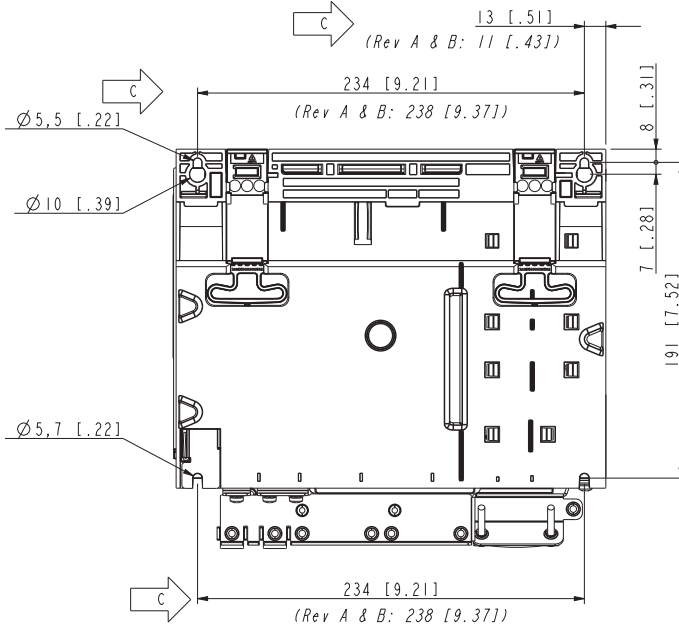
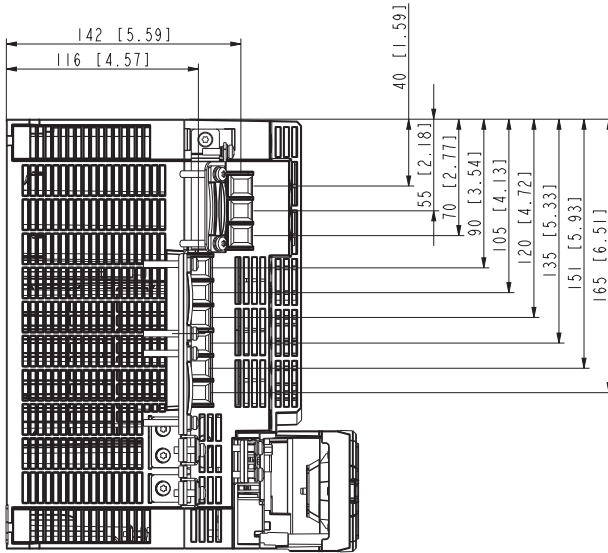

■ Frame R4 (front & side) - UL Type 1 kit installed

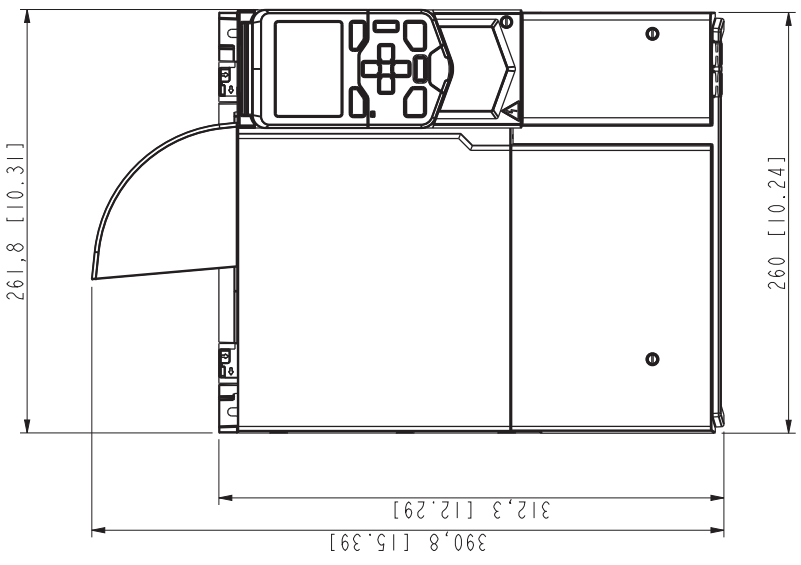
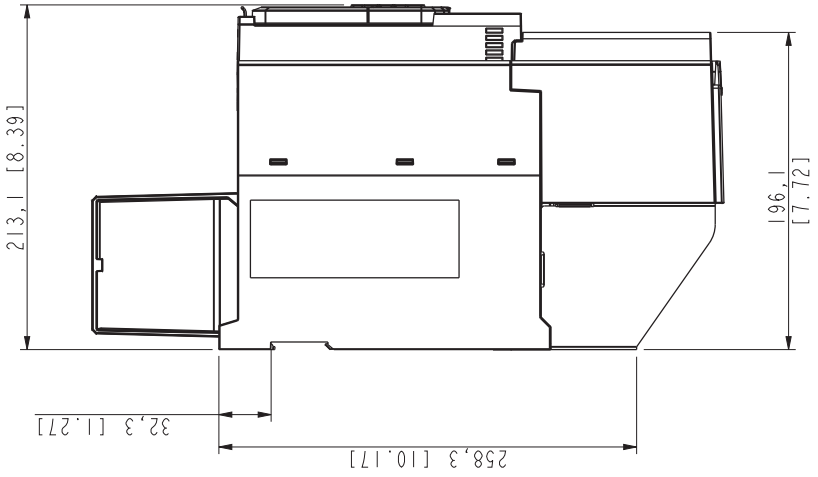

■ **Frame R4 (bottom & rear) - UL Type 1 kit installed**

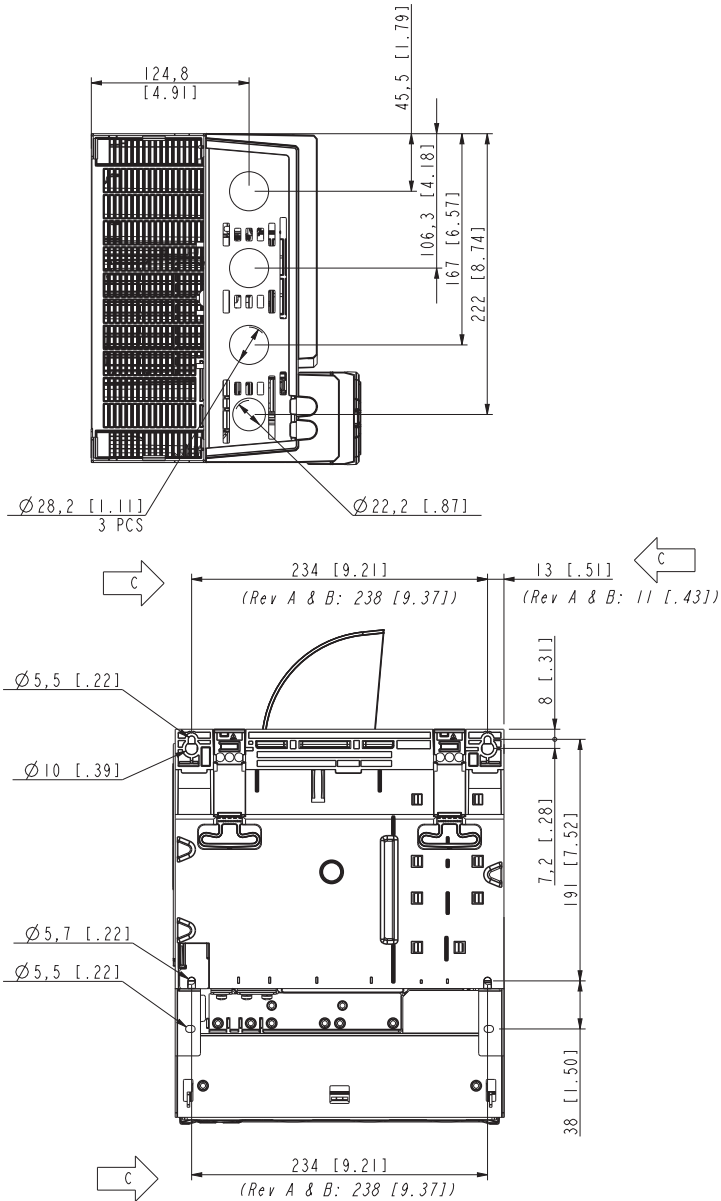



Input chokes

Contents of this chapter

This chapter describes how to select and install input chokes for the drive. The chapter also contains the technical data of the input chokes.

When is an input choke necessary?

Determine the need for an external input choke at the drive power input on a case-by-case basis. The input chokes are used:

- to protect the drive in networks with high short-circuit capacity. Refer to [Input choke \(page 167\)](#) in section [Electrical power network specification \(page 166\)](#).
- to reduce harmonic current emissions. Refer to [Compliance with the harmonic current limits in a public network \(IEC/EN 61000 3-2, IEC/EN 61000-3-12\) \(page 176\)](#).
- to reduce the rms value of input current. Refer to [Maximum input current \(page 203\)](#).
- to reduce supply disturbance and low-frequency interference
- in common DC configurations.

Maximum input current

Input current (I_1) of the drive depends on these items:

- motor actual shaft power and efficiency
-

204 Input chokes

- power output (or input) via DC connection to other drives in the common DC setup
- network impedance (short circuit capacity) effect on total harmonics content of the input current. Refer to [Electrical power network specification \(page 166\)](#) for more information.

Below are the maximum continuous input current values (rms) allowed for different drive types. If the actual continuous input current is higher (eg, due to very low efficiency of the motor), it is possible to use an input choke to reduce the input current rms value.

■ IEC

1-phase 230 V AC		3-phase 230 V AC		3-phase 400 V AC	
ACS480-...	I_1	ACS480-...	I_1	ACS480-...	I_1
	A		A		A
02A3-1	5.5	02A4-2	3.4	02A7-4	3.5
03A5-1	7.4	03A7-2	4.5	03A4-4	4.8
04A8-1	9.1	04A8-2	5.7	04A1-4	6.1
06A6-1	12.6	06A9-2	7.8	05A7-4	8.5
07A4-1	14.9	07A8-2	9.3	07A3-4	10.1
09A3-1	21.0	09A8-2	12.8	09A5-4	12.9
11A6-1	21.0	12A2-2	16.0	12A7-4	16.5
-	-	17A5-2	20.7	018A-4	23.4
-	-	25A0-2	27.2	026A-4	31.8
-	-	032A-2	37.4	033A-4	40.7
-	-	048A-2	53.2	039A-4	49.0
-	-	-	-	046A-4	55.7
-	-	-	-	050A-4	55.7

ACS480-...	Frame	Input choke type										
		CHK-A1	CHK-B1	CHK-C1	CHK-D1	CHK-01	CHK-02	CHK-03	CHK-04	CHK-05	CHK-06	CHK-07
050A-4	R4											x

The degree of protection of an input choke is IP20. Refer to [Dimensions \(page 208\)](#) for dimensions, wire sizes and tightening torques.

Guidelines for installing an input choke

Obey these guidelines when you install the input choke:

- If an external EMC filter is also installed, connect the input choke between the supply and the filter.
- For optimal operation of the choke, fasten the drive and the choke on the same conductive surface.
- Make sure that the choke does not prevent the airflow through the drive module, and that the hot air rising from the choke cannot enter the air inlet of the drive module.
- Keep the cable between the drive and the choke as short as possible.



WARNING!

The input choke is hot when in use and for some time after the use.

■ **Connection diagram**

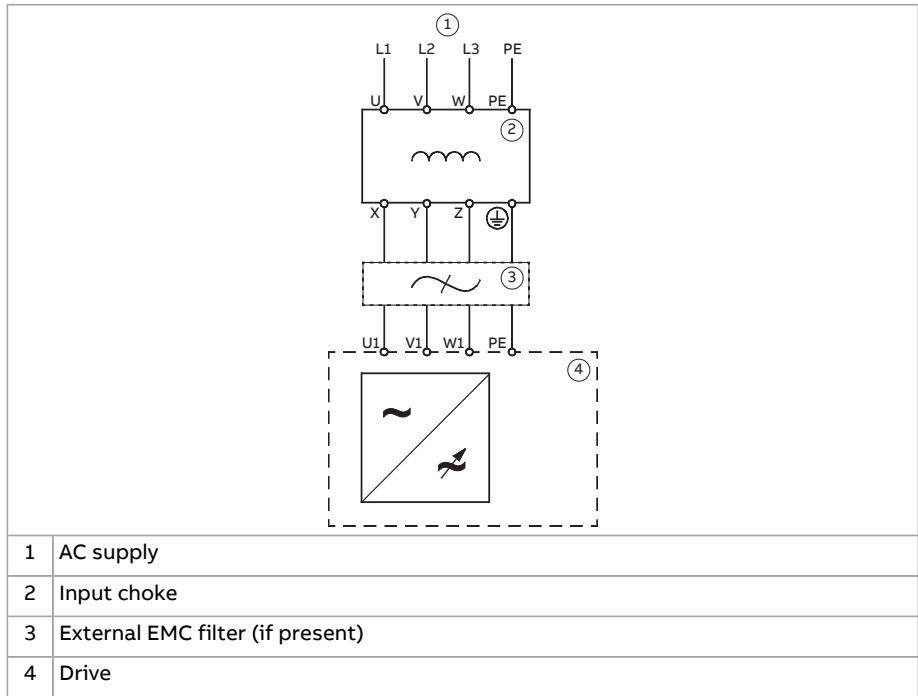

Dimensions

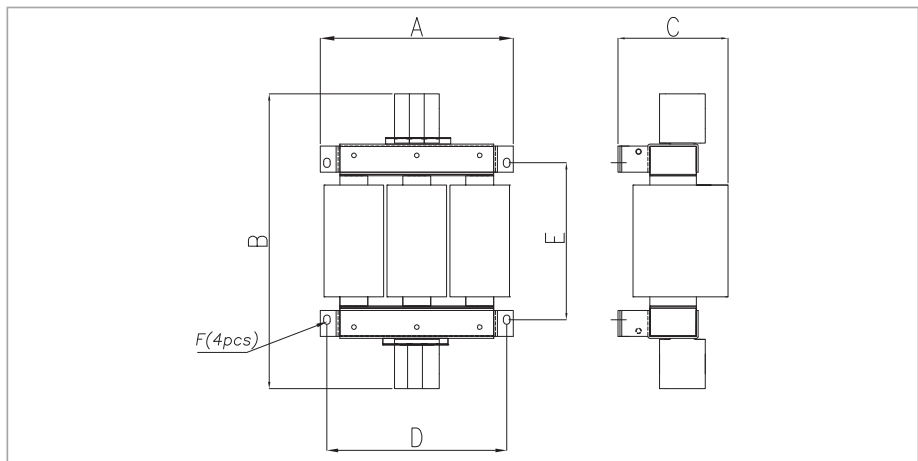

	Input choke type							
	CHK-01	CHK-02	CHK-03	CHK-04	CHK-05	CHK-06	CHK-07	CHK-08
Dim A mm (in.)	120 (4.72)	150 (5.91)	150 (5.91)	150 (5.91)	207 (8.15)	207 (8.15)	249 (9.80)	249 (9.80)
Dim B mm (in.)	146 (5.75)	175 (6.89)	175 (6.89)	175 (6.89)	272 (10.71)	326 (12.83)	326 (12.83)	346 (13.62)
Dim C mm (in.)	79 (3.11)	86 (3.39)	100 (3.94)	100 (3.94)	154 (6.06)	154 (6.06)	167 (6.57)	167 (6.57)
Dim D mm (in.)	77 (3.03)	105 (4.13)	105 (4.13)	105 (4.13)	193 (7.60)	193 (7.60)	235 (9.25)	235 (9.25)
Dim E mm (in.)	114 (4.49)	148 (5.83)	148 (5.83)	148 (5.83)	118 (4.65)	169 (6.65)	125 (4.92)	147 (5.79)
F screw size	M5	M5	M5	M5	M6	M6	M6	M6
Weight kg (lbs)	1.8 (4.0)	3.8 (8.4)	5.4 (11.9)	5.2 (11.5)	10 (22)	12 (26.5)	14 (31)	16 (35)
Wire size Main terminals mm ² (AWG)	0.5...10 (20...6)	0.5...10 (20...6)	0.5...10 (20...6)	0.5...10 (20...6)	1.5...35 (16...0)	1.5...35 (16...0)	25...50 (6...0)	25...50 (6...0)
Tightening torque Main terminals N·m (lbf·in)	1.5 (13)	1.5 (13)	1.5 (13)	1.5 (13)	3.2 (28)	3.2 (28)	6 (53)	6 (53)
PE/Chassis ter- minals	M4	M5	M5	M5	M6	M6	M6	M8
Tightening torque PE/Chassis ter- minals N·m (lbf·in)	3 (26)	4 (35)	4 (35)	4 (35)	8 (70)	8 (70)	8 (70)	15 (135)

13

External EMC filters

Contents of this chapter

This chapter describes how to select external EMC filters for the drive.

Selecting the external EMC filter

If you use an external EMC filter, you must disconnect the internal EMC filter. Refer to the electrical installation instructions.

Select the external EMC filter according to the drive type:

IEC type ACS480-...	EMC filter type	
	ABB order code	Schaffner order code
1-phase $U_n = 230\text{ V}$		
02A4-1	RFI-11	FS 21754-6.1-07
03A7-1	RFI-12	FS 21754-16.1-07
04A8-1	RFI-12	FS 21754-16.1-07
06A9-1	RFI-12	FS 21754-16.1-07
07A8-1	RFI-12	FS 21754-16.1-07
3-phase $U_n = 230\text{ V}$		
02A4-2	RFI-32	FN 3258-16-44
03A7-2	RFI-32	FN 3258-16-44
04A8-2	RFI-32	FN 3258-16-44

212 External EMC filters

IEC type ACS480-...	EMC filter type	
	ABB order code	Schaffner order code
06A9-2	RFI-32	FN 3258-16-44
07A8-2	RFI-32	FN 3258-16-44
09A8-2	RFI-32	FN 3258-16-44
12A2-2	RFI-33	FN 3258-30-33
17A5-2	RFI-33	FN 3258-30-33
25A0-2	RFI-33	FN 3258-30-33
032A-2	RFI-34	FN 3258-100-35
048A-2	RFI-34	FN 3258-100-35
3-phase $U_n = 400$ V		
02A7-4	RFI-32	FN 3258-16-44
03A4-4	RFI-32	FN 3258-16-44
04A1-4	RFI-32	FN 3258-16-44
05A7-4	RFI-32	FN 3258-16-44
07A3-4	RFI-32	FN 3258-16-44
09A5-4	RFI-32	FN 3258-16-44
12A7-4	RFI-33	FN 3258-30-33
018A-4	RFI-33	FN 3258-30-33
026A-4	RFI-33	FN 3258-30-33
033A-4	RFI-34	FN 3258-100-35
039A-4	RFI-34	FN 3258-100-35
046A-4	RFI-34	FN 3258-100-35
050A-4	RFI-34	FN 3258-100-35
UL (NEC) type ACS480-...	EMC filter type	
	ABB type code	Schaffner order code
1-phase $U_n = 230$ V		
02A3-1	RFI-11	FS 21754-6.1-07
03A5-1	RFI-12	FS 21754-16.1-07
04A6-1	RFI-12	FS 21754-16.1-07
06A6-1	RFI-12	FS 21754-16.1-07
07A4-1	RFI-12	FS 21754-16.1-07

UL (NEC) type ACS480-...	EMC filter type	
	ABB type code	Schaffner order code
3-phase $U_n = 230$ V		
02A3-2	RFI-32	FN 3258-16-44
03A5-2	RFI-32	FN 3258-16-44
04A6-2	RFI-32	FN 3258-16-44
06A6-2	RFI-32	FN 3258-16-44
07A5-2	RFI-32	FN 3258-16-44
11A6-2	RFI-33	FN 3258-30-33
017A-2	RFI-33	FN 3258-30-33
024A-2	RFI-33	FN 3258-30-33
031A-2	RFI-34	FN 3258-100-35
046A-2	RFI-34	FN 3258-100-35
3-phase $U_n = 480$ V		
02A1-4	RFI-32	FN 3268-16-44
03A0-4	RFI-32	FN 3268-16-44
03A5-4	RFI-32	FN 3268-16-44
04A8-4	RFI-32	FN 3268-16-44
06A0-4	RFI-32	FN 3268-16-44
07A6-4	RFI-32	FN 3268-16-44
011A-4	RFI-33	FN 3268-30-33
014A-4	RFI-33	FN 3268-30-33
021A-4	RFI-33	FN 3268-30-33
027A-4	RFI-34	FN 3258-100-35
034A-4	RFI-34	FN 3258-100-35
042A-4	RFI-34	FN 3258-100-35

See also [EMC compatibility and motor cable length and EMC compliance \(IEC/EN 61800-3:2004 + A1:2012\) \(page 177\)](#). For compliance information, refer to [Category C1 \(page 178\)](#).

14

Resistor braking

Contents of this chapter

The chapter describes how to select the brake resistor and cables, protect the system, connect the brake resistor and enable resistor braking.

Safety



WARNING!

Do not do work on the brake resistor or the resistor cable when the drive is energized. A dangerous voltage is present in the resistor circuit, even when the brake chopper is not operating, or when it is disabled by a parameter.

Operation principle

The brake chopper handles the extra energy generated by motor during a quick deceleration. The extra energy increases the drive DC link voltage. The chopper connects the brake resistor to the DC link whenever the voltage is greater than the limit defined by the control program. Energy consumption by the resistor losses lowers the voltage until the resistor can be disconnected.

Selecting the brake resistor

Drives have a built-in brake chopper as standard equipment. The brake resistor is selected using the table and equations shown in this section.

1. Determine the required maximum braking power P_{Rmax} for the application. P_{Rmax} must be smaller than P_{BRmax} . Refer to [Reference brake resistors \(page 217\)](#).
-

216 Resistor braking

2. Calculate resistance R with Equation 1.
3. Calculate energy E_{Rpulse} with Equation 2.
4. Select the resistor so that the following conditions are met:
 - The rated power of the resistor must be greater than or equal to P_{Rmax} .
 - Resistance R must be between R_{min} and R_{max} given in the table for the used drive type.
 - The resistor must be able to dissipate energy E_{Rpulse} during the braking cycle T .

Equations for selecting the resistor:

Equation 1

When the drive supply voltage is 200 ... 240 V:

$$R = \frac{150\,000}{P_{Rmax}}$$

When the drive supply voltage is 380 ... 415 V:

$$R = \frac{450\,000}{P_{Rmax}}$$

When the drive supply voltage is 415 ... 480 V:

$$R = \frac{615\,000}{P_{Rmax}}$$

Equation 2

$$E_{Rpulse} = P_{Rmax} \cdot t_{on}$$

Equation 3

$$P_{Rave} = P_{Rmax} \cdot \frac{t_{on}}{T}$$

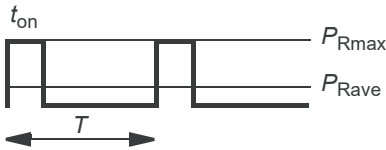

For conversion, use $1\text{ hp} = 746\text{ W}$.

R	Calculated brake resistor value (ohm). Make sure that: $R_{min} < R < R_{max}$
P_{Rmax}	Maximum power during the braking cycle (W)
P_{Rave}	Average power during the braking cycle (W)
E_{Rpulse}	Energy conducted into the resistor during a single braking pulse (J)
t_{on}	Braking time (one cycle) (s)
T	Braking cycle time (s)

**WARNING!**

Do not use a brake resistor with a resistance below the minimum value specified for the particular drive. The drive and the internal chopper are not able to handle the overcurrent caused by the low resistance.

■ Reference brake resistors

IEC type ACS480- 04-...	R_{min}	R_{max}	P_{BRcont}		P_{BRmax}		Example resistor types ^{1) 2)}
	ohm	ohm	kW	hp	kW	hp	Danotherm
1-phase $U_n = 230$ V							
02A4-1	32.5	468	0.25	0.33	0.38	0.50	CBH 360 C T 406 210R or CAR 200 D T 406 210R
03A7-1	32.5	316	0.37	0.50	0.56	0.74	
04A8-1	32.5	213	0.55	0.75	0.83	1.10	CBR-V 330 D T 406 78R UL
06A9-1	32.5	145	0.75	1.00	1.10	1.50	
07A8-1	32.5	96.5	1.10	1.50	1.70	2.20	CBR-V 560 D HT 406 39R UL
09A8-1	32.5	69.9	1.50	2.00	2.30	3.00	
12A2-1	19.5	47.1	2.20	3.00	3.30	4.40	
3-phase $U_n = 230$ V							
02A4-2	39	474	0.25	0.33	0.38	0.50	CBH 360 C T 406 210R or CAR 200 D T 406 210R
03A7-2	39	319	0.37	0.50	0.56	0.74	
04A8-2	39	217	0.55	0.75	0.83	1.10	CBR-V 330 D T 406 78R UL
06A9-2	39	145	0.75	1.00	1.13	1.50	
07A8-2	39	105	1.10	1.50	1.65	2.20	CBR-V 560 D HT 406 39R UL
09A8-2	20	71	1.50	2.00	2.25	3.00	
12A2-2	20	52	2.20	2.00	3.30	4.40	
17A5-2	16	38	3.00	3.00	4.50	6.00	CBT-H 560 D HT 406 19R
25A0-2	16	28	4.00	5.00	6.00	8.00	
032A-2	3	20	5.50	7.50	8.25	11.00	CBT-V 760 G H T 282 8R
048A-2	3	14	7.50	10.00	11.25	15.00	

218 Resistor braking

IEC type ACS480- 04-...	R_{min}	R_{max}	P_{BRcont}		P_{BRmax}		Example resistor types ^{1) 2)}
	ohm	ohm	kW	hp	kW	hp	Danotherm
3-phase $U_n = 400$ V							
02A7-4	99	628	0.55	0.75	0.83	1.10	CBH 360 C T 406 210R or CAR 200 D T 406 210R
03A4-4	99	428	0.75	1.00	1.13	1.50	
04A1-4	99	285	1.10	1.50	1.65	2.20	
05A7-4	99	206	1.50	2.00	2.25	3.00	
07A3-4	53	139	2.20	2.00	3.30	4.40	CBR-V 330 D T 406 78R UL
09A5-4	53	102	3.00	3.00	4.50	6.00	
12A7-4	32	76	4.00	5.00	6.00	8.00	
018A-4	32	54	5.50	7.50	8.25	11.00	CBR-V 560 D HT 406 39R
026A-4	23	39	7.50	10.00	11.25	15.00	
033A-4	6	29	11.00	15.00	17	22.00	CBT-H 560 D HT 406 19R
039A-4	6	24	15.00	20.00	23	30.00	CBT-H 760 D HT 406 16R
046A-4	6	20	18.50	25.00	28	37.00	
050A-4	6	20	22.00	30.00	33	44.00	

¹⁾ Braking cycle differs from that of the drive. Refer to brake resistor manufacturer's documentation.

²⁾ If brake resistors from other manufacturers are used, the characteristics must agree with the values in the table.

UL (NEC) type ACS480- 04-...	R_{min}	R_{max}	P_{BRcont}		P_{BRmax}		Example resistor types ^{1) 2)}
	ohm	ohm	kW	hp	kW	hp	Danotherm
1-phase $U_n = 230$ V							
02A3-1	32.5	468	0.25	0.33	0.33	0.50	CBH 360 C T 406 210R or CAR 200 D T 406 210R
03A5-1	32.5	316	0.37	0.50	0.56	0.74	
04A6-1	32.5	213	0.55	0.75	0.83	1.10	
06A6-1	32.5	145	0.75	1.00	1.10	1.50	CBR-V 330 D T 406 78R UL
07A4-1	32.5	96.5	1.10	1.50	1.70	2.20	
09A3-1	32.5	69.9	1.50	2.00	2.30	3.0	CBR-V 560 D HT 406 39R UL
11A6-1	19.5	47.1	2.20	3.00	3.30	4.40	

UL (NEC) type ACS480- 04-...	R_{min}	R_{max}	P_{BRcont}		P_{BRmax}		Example resistor types ^{1) 2)}
	ohm	ohm	kW	hp	kW	hp	Danotherm
3-phase $U_n = 230$ V							
02A3-2	39	474	0.25	0.33	0.38	0.50	CBH 360 C T 406 210R or CAR 200 D T 406 210R
03A5-2	39	319	0.37	0.50	0.56	0.74	
04A6-2	39	217	0.55	0.75	0.83	1.10	
06A6-2	39	145	0.75	1.00	1.13	1.50	CBR-V 330 D T 406 78R UL
07A5-2	39	105	1.10	1.50	1.65	2.20	
11A6-2	20	52	2.20	2.00	3.30	4.40	CBR-V 560 D HT 406 39R UL
017A-2	16	38	3.00	3.00	4.50	6.00	
024A-2	16	28	4.00	5.00	6.00	8.00	CBT-H 560 D HT 406 19R
031A-2	3	20	5.50	7.50	8.25	11.00	
046A-2	3	14	7.50	10.00	11.25	15.00	
3-phase $U_n = 480$ V							
02A1-4	99	628	0.55	0.75	0.83	1.10	CBH 360 C T 406 210R or CAR 200 D T 406 210R
03A0-4	99	428	0.75	1.00	1.13	1.50	
03A5-4	99	285	1.10	1.50	1.65	2.20	
04A8-4	99	206	1.50	2.00	2.25	3.00	
06A0-4	53	139	2.20	2.00	3.30	4.40	CBR-V 330 D T 406 78R UL
07A6-4	53	102	3.00	3.00	4.50	6.00	
011A-4	32	76	4.00	5.00	6.00	8.00	
014A-4	32	54	5.50	7.50	8.25	11.00	CBR-V 560 D HT 406 39R
021A-4	23	39	7.50	10.00	11.25	15.00	
027A-4	6	29	11.00	15.00	17	22.00	CBT-H 560 D HT 406 19R
034A-4	6	24	15.00	20.00	23	30.00	
042A-4	6	20	22.00	30.00	33	44.00	CBT-H 760 D HT 406 16R

1) Braking cycle differs from that of the drive. Refer to brake resistor manufacturer's documentation.

2) If brake resistors from other manufacturers are used, the characteristics must agree with the values in the table.

Definitions

P_{BRmax}	The maximum braking capacity of the drive, when the length of the braking pulse is at most 1 minute for each 10 minutes ($P_{BRcont} \times 1.5$). Must be more than the desired braking power.
P_{BRcont}	The continuous braking capacity of the drive
R_{max}	The maximum resistance value of the brake resistor that can provide P_{BRcont}
R_{min}	The minimum permitted resistance value of the brake resistor

Selecting and routing the brake resistor cables

Use a shielded cable specified in the technical data.

■ Minimizing electromagnetic interference

Make sure that the installation is compliant with the EMC requirements. Obey these rules in order to minimize electromagnetic interference caused by the rapid voltage and current changes in the resistor cables:

- Shield the brake resistor cable. Use shielded cable or a metallic enclosure. If you use unshielded single-core cables, route them inside a cabinet that efficiently suppresses the radiated emissions.
- Install the cables away from other cable routes.
- Avoid long parallel runs with other cables. The minimum parallel cabling separation distance is 0.3 meters (1 ft).
- Cross the other cables at 90° angles.
- Keep the cable as short as possible in order to minimize the radiated emissions and stress on the brake chopper. The longer the cable the greater the radiated emissions, inductive load and voltage peaks over the IGBT semiconductors of the brake chopper.

■ Maximum cable length

The maximum length of the resistor cable(s) is 10 m (33 ft).

Selecting the installation location for the brake resistors

Protect the open (IP00) brake resistors against contact. Install the brake resistor in a place where it cools effectively. Arrange the cooling of the resistor so that:

- no danger of overheating is caused to the resistor or nearby materials, and
 - the temperature of the space that the resistor is in does not go above the allowed maximum value.
-

**WARNING!**

The materials near the brake resistor must be non-flammable. The surface temperature of the resistor is high. Air flowing from the resistor is of hundreds of degrees Celsius. If the exhaust vents are connected to a ventilation system, make sure that the material withstands high temperatures. Protect the resistor against contact.

Protecting the system in brake circuit fault situations

■ Protecting the system in cable and brake resistor short-circuit situations

The drive input fuses will also protect the resistor cable when it is identical with the input power cable.

■ Protecting the system against thermal overload

The drive has a brake thermal model which protects the brake resistor against overload. ABB recommends to enable the thermal model at start up.

ABB recommends to equip the drive with a main contactor for safety reasons even when you have enabled the resistor thermal model. Wire the contactor so that it opens in case the resistor overheats. This is essential for safety since the drive will not otherwise be able to interrupt the main supply if the chopper remains conductive in a fault situation. An example wiring diagram is shown below. ABB recommends that you use resistors equipped with a thermal switch (1) inside the resistor assembly. The switch indicates overtemperature.

ABB recommends that you also wire the thermal switch to a digital input of the drive, and configure the input to cause a fault trip at resistor overtemperature indication.

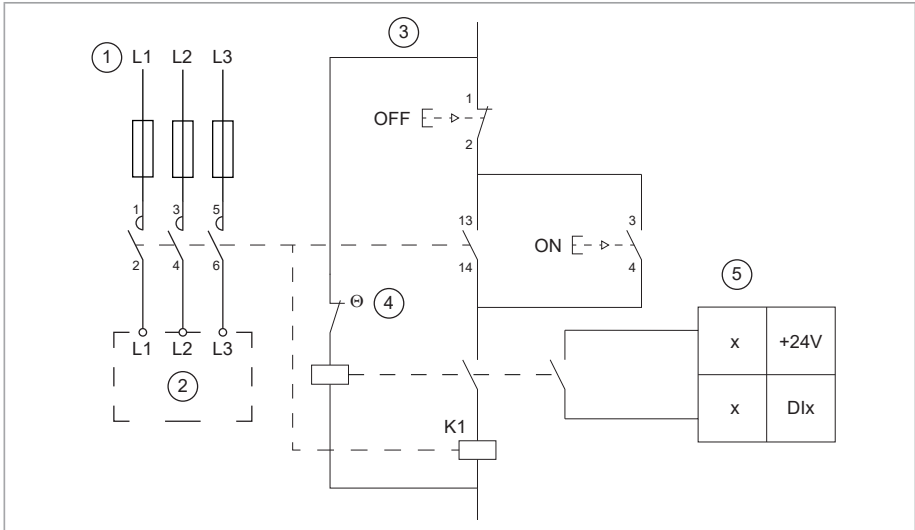

1	Drive input power connection with a main contactor
2	Drive
3	Main contactor control circuit
4	Brake resistor thermal switch
5	Digital input. Monitors the brake resistor thermal switch.

Mechanical and electrical installation of brake resistor

WARNING! Obey the safety instructions of the drive. If you ignore them, injury or death, or damage to the equipment can occur. If you are not a qualified electrical professional, do not do installation, commissioning or maintenance work.

WARNING! Stop the drive and do the steps in section [Electrical safety precautions \(page 18\)](#) before you start the work.

■ Mechanical installation

Refer to the resistor manufacturer’s instructions.

■ Electrical installation

Measuring the insulation

See the electrical installation instructions of the drive.

Connecting power cables

See the electrical installation instructions of the drive.

Connection the control cables

Connect the thermal switch of the brake resistor as described in [Protecting the system against thermal overload \(page 221\)](#).

Start-up

Set the following parameters:

1. Disable the overvoltage control of the drive with parameter 30.30 Overvoltage control.
2. Set the source of parameter 31.01 External event 1 source to point to the digital input where the thermal switch of the brake resistor is wired.
3. Set parameter 31.02 External event 1 type to Fault.
4. Enable the brake chopper by parameter 43.06 Brake chopper enable. If Enabled with thermal model is selected, set also the brake resistor overload protection parameters 43.08 and 43.09 according to the application.
5. Check the resistance value of parameter 43.10 Brake resistance.

With these parameter settings, the drive generates a fault and coasts to a stop on brake resistor overtemperature.

15

The Safe torque off function

Contents of this chapter

This chapter describes the Safe torque off (STO) function of the drive and gives instructions for its use.

Description

The Safe torque off function can be used, for example, as the final actuator device of safety circuits (such as an emergency stop circuit) that stop the drive in case of danger. Another typical application is a prevention of unexpected start-up function that enables short-time maintenance operations like cleaning or work on non-electrical parts of the machinery without switching off the power supply to the drive.

When activated, the Safe torque off function disables the control voltage for the power semiconductors of the drive output stage, thus preventing the drive from generating the torque required to rotate the motor. If the motor is running when Safe torque off is activated, it coasts to a stop.

The Safe torque off function has a redundant architecture, that is, both channels must be used in the safety function implementation. The safety data given in this manual is calculated for redundant use, and does not apply if both channels are not used.

The Safe torque off function complies with these standards:

Standard	Name
IEC 60204-1:2021 EN 60204-1:2018	Safety of machinery – Electrical equipment of machines – Part 1: General requirements
IEC 61000-6-7:2014	Electromagnetic compatibility (EMC) – Part 6-7: Generic standards – Immunity requirements for equipment intended to perform functions in a safety-related system (functional safety) in industrial locations
IEC 61326-3-1:2017	Electrical equipment for measurement, control and laboratory use – EMC requirements – Part 3-1: Immunity requirements for safety-related systems and for equipment intended to perform safety-related functions (functional safety) – General industrial applications
IEC 61508-1:2010	Functional safety of electrical/electronic/programmable electronic safety-related systems – Part 1: General requirements
IEC 61508-2:2010	Functional safety of electrical/electronic/programmable electronic safety-related systems – Part 2: Requirements for electrical/electronic/programmable electronic safety-related systems
IEC 61511-1:2017	Functional safety – Safety instrumented systems for the process industry sector
IEC 61800-5-2:2016 EN 61800-5-2:2007	Adjustable speed electrical power drive systems – Part 5-2: Safety requirements – Functional
EN IEC 62061:2021	Safety of machinery – Functional safety of safety-related control systems
EN ISO 13849-1:2015	Safety of machinery – Safety-related parts of control systems – Part 1: General principles for design
EN ISO 13849-2:2012	Safety of machinery – Safety-related parts of control systems – Part 2: Validation

The function also corresponds to Prevention of unexpected start-up as specified by EN ISO 14118:2018 (ISO 14118:2017), and Uncontrolled stop (stop category 0) as specified in EN/IEC 60204-1.

■ **Compliance with the European Machinery Directive and the UK Supply of Machinery (Safety) Regulations**

See the technical data.

Wiring

For the electrical specifications of the STO connection, see the technical data of the control unit.

■ Connection principle

Single ACS480 drive, internal power supply

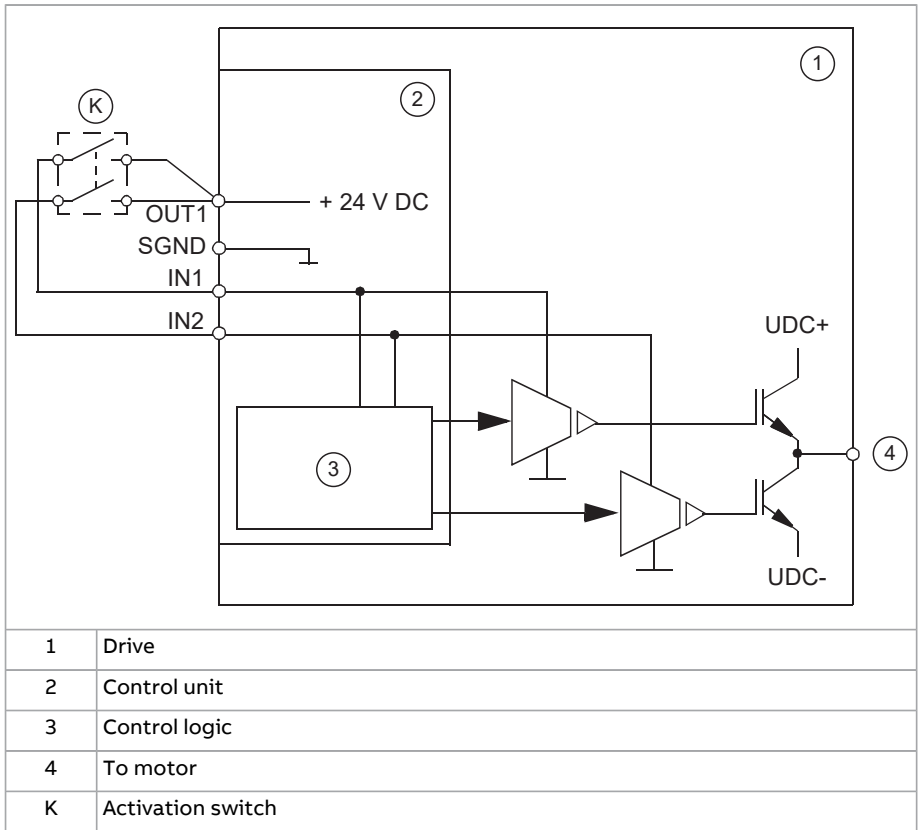

Single ACS480 drive, external power supply

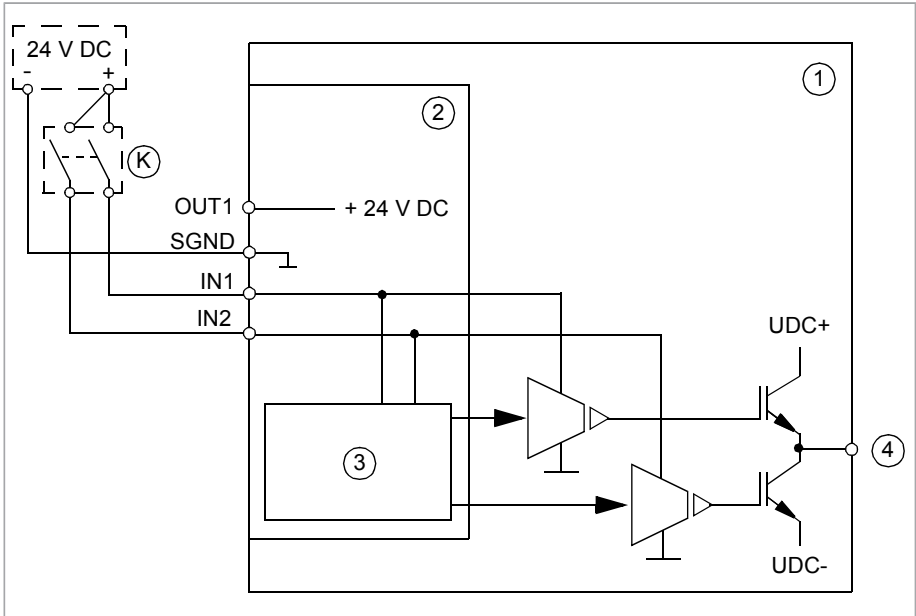

1	Drive
2	Control unit
3	Control logic
4	To motor
K	Activation switch

■ Wiring examples

Single ACS480 drive, internal power supply

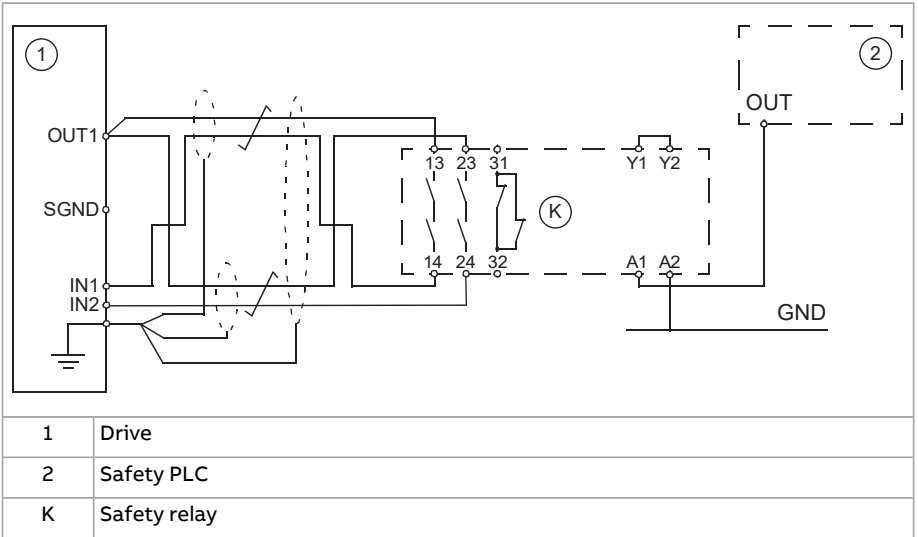

Single ACS480 drive, external power supply

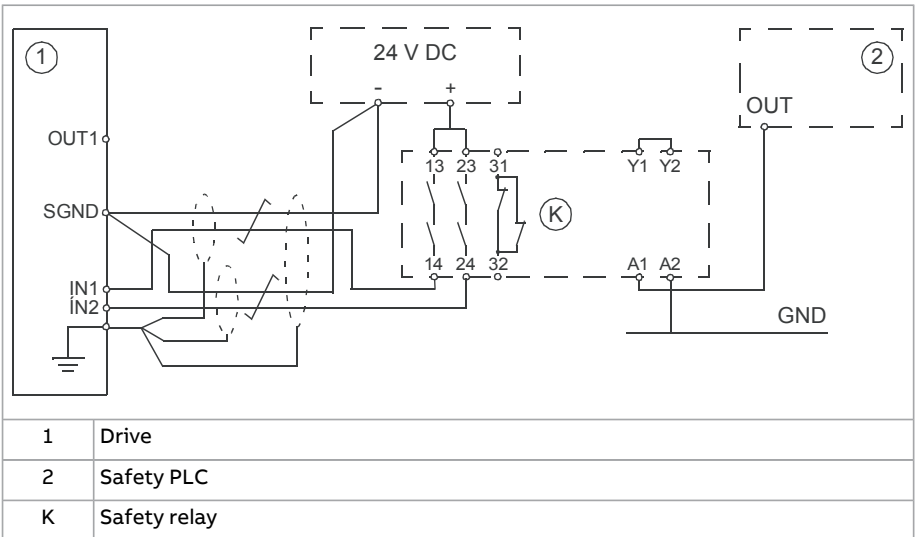

Multiple ACS480 drives, internal power supply

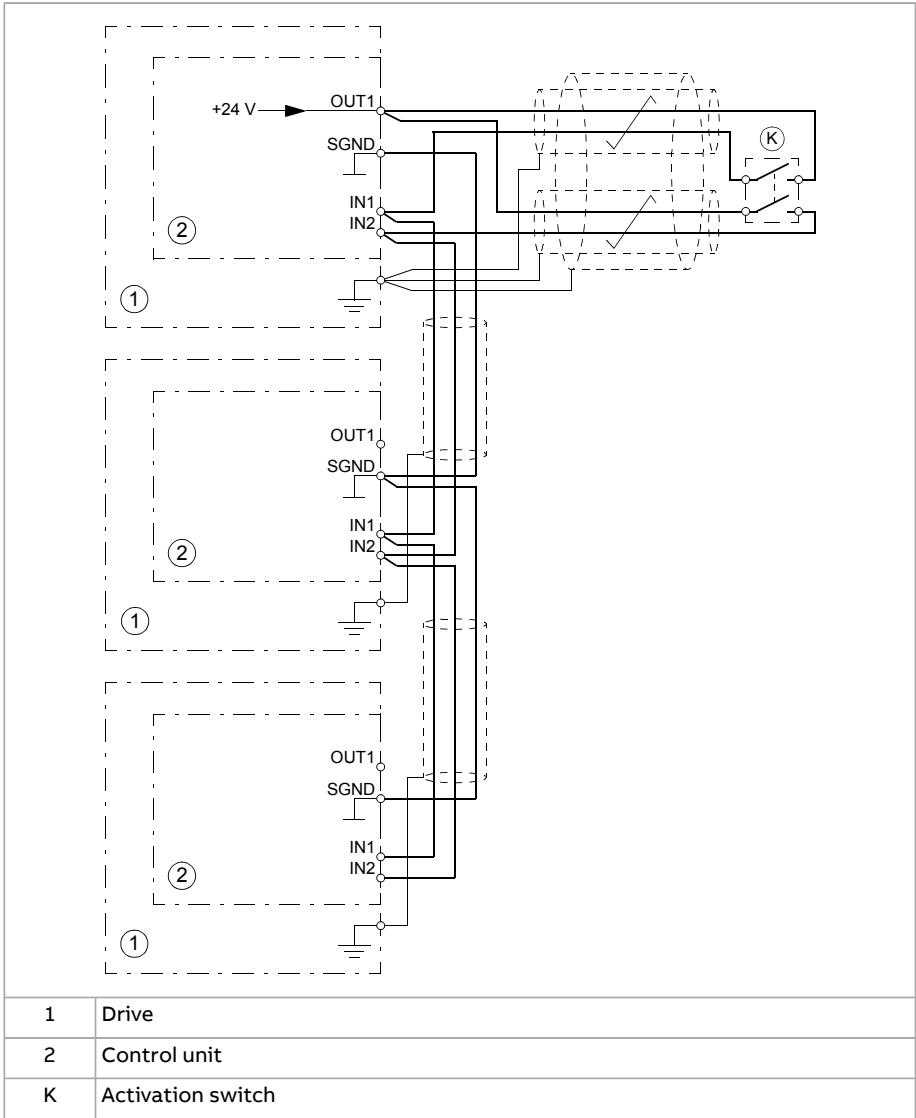

Multiple ACS480 drives, external power supply

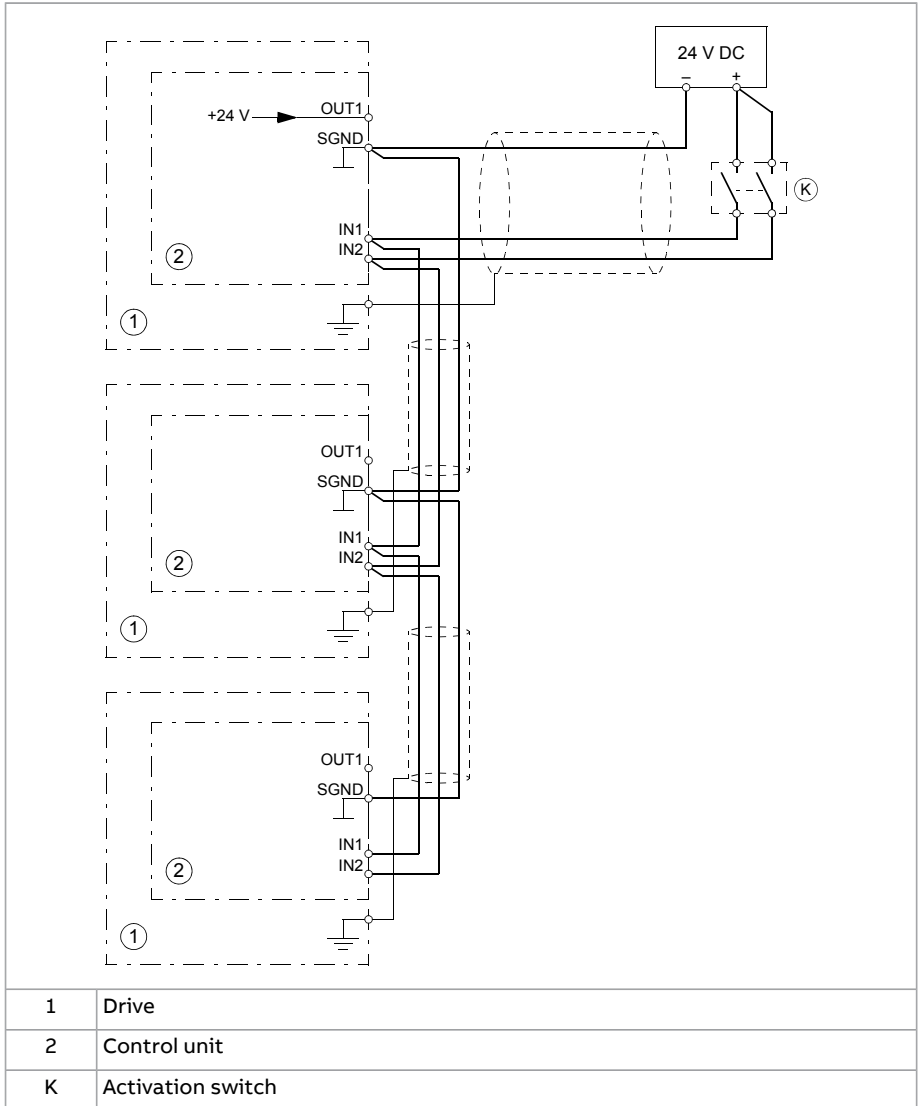

■ Activation switch

In the wiring diagrams, the activation switch has the designation [K]. This represents a component such as a manually operated switch, an emergency stop push button switch, or the contacts of a safety relay or safety PLC.

- In case a manually operated activation switch is used, the switch must be of a type that can be locked out to the open position.
- The contacts of the switch or relay must open/close within 200 ms of each other.

■ Cable types and lengths

- ABB recommends double-shielded twisted-pair cable.
- Maximum cable lengths:
 - 300 m (1000 ft) between activation switch [K] and drive control unit
 - 60 m (200 ft) between multiple drives
 - 60 m (200 ft) between external power supply and first control unit

Note: A short-circuit in the wiring between the switch and an STO terminal causes a dangerous fault. Therefore, it is recommended to use a safety relay (including wiring diagnostics) or a wiring method (shield grounding, channel separation) which reduces or eliminates the risk caused by the short-circuit.

Note: The voltage at the STO input terminals of the drive must be at least 13 V DC to be interpreted as “1”.

The pulse tolerance of the input channels is 1 ms.

■ Grounding of protective shields

- Ground the shield in the cabling between the activation switch and the control unit at the control unit only.
 - Ground the shield in the cabling between two control units at one control unit only.
-

Operation principle

1. The Safe torque off activates (the activation switch is opened, or safety relay contacts open).
2. The STO inputs of the drive control unit de-energize.
3. The control unit cuts off the control voltage from the output IGBTs.
4. The control program generates an indication as defined by parameter 31.22 (see the firmware manual of the drive).

The parameter selects which indications are given when one or both STO signals are switched off or lost. The indications also depend on whether the drive is running or stopped when this occurs.

Note: This parameter does not affect the operation of the STO function itself. The STO function will operate regardless of the setting of this parameter: a running drive will stop upon removal of one or both STO signals, and will not start until both STO signals are restored and all faults reset.

Note: The loss of only one STO signal always generates a fault as it is interpreted as a malfunction of STO hardware or wiring.

5. The motor coasts to a stop (if running). The drive cannot restart while the activation switch or safety relay contacts are open. After the contacts close, a reset may be needed (depending on the setting of parameter 31.22). A new start command is required to start the drive.
-

Start-up including validation test

To ensure the safe operation of a safety function, validation is required. The final assembler of the machine must validate the function by performing a validation test. The test must be performed

1. at initial start-up of the safety function
2. after any changes related to the safety function (circuit boards, wiring, components, settings, replacement of inverter module, etc.)
3. after any maintenance work related to the safety function
4. after a drive firmware update
5. at the proof test of the safety function.

■ Competence

The validation test of the safety function must be carried out by a competent person with adequate expertise and knowledge of the safety function as well as functional safety, as required by IEC 61508-1 clause 6. The test procedures and report must be documented and signed by this person.

■ Validation test reports

Signed validation test reports must be stored in the logbook of the machine. The report shall include documentation of start-up activities and test results, references to failure reports and resolution of failures. Any new validation tests performed due to changes or maintenance shall be logged into the logbook.

■ Validation test procedure

After wiring the Safe torque off function, validate its operation as follows.

Action	<input checked="" type="checkbox"/>
 WARNING! Obey the safety instructions. If you ignore them, injury or death, or damage to the equipment can occur.	<input type="checkbox"/>
Make sure that the motor can be run and stopped freely during start-up.	<input type="checkbox"/>
Stop the drive (if running), switch the input power off and isolate the drive from the power line using a disconnecter.	<input type="checkbox"/>
Check the STO circuit connections against the wiring diagram.	<input type="checkbox"/>
Close the disconnecter and switch the power on.	<input type="checkbox"/>

Action	<input checked="" type="checkbox"/>
<p>Test the operation of the STO function when the motor is stopped.</p> <ul style="list-style-type: none"> • Give a stop command for the drive (if running) and wait until the motor shaft is at a standstill. <p>Make sure that the drive operates as follows:</p> <ul style="list-style-type: none"> • Open the STO circuit. The drive generates an indication if one is defined for the 'stopped' state in parameter 31.22 (see the firmware manual). • Give a start command to verify that the STO function blocks the drive's operation. The motor should not start. • Close the STO circuit. • Reset any active faults. Restart the drive and check that the motor runs normally. 	<input type="checkbox"/>
<p>Test the operation of the STO function when the motor is running.</p> <ul style="list-style-type: none"> • Start the drive and make sure the motor is running. • Open the STO circuit. The motor should stop. The drive generates an indication if one is defined for the 'running' state in parameter 31.22 (see the firmware manual). • Reset any active faults and try to start the drive. • Make sure that the motor stays at a standstill and the drive operates as described above in testing the operation when the motor is stopped. • Close the STO circuit. • Reset any active faults. Restart the drive and check that the motor runs normally. 	<input type="checkbox"/>
<p>Test the operation of the failure detection of the drive. The motor can be stopped or running.</p> <ul style="list-style-type: none"> • Open the 1st input channel of the STO circuit. If the motor was running, it should coast to a stop. The drive generates an FA81 fault indication (see the firmware manual). • Give a start command to verify that the STO function blocks the drive's operation. The motor should not start. • Open the STO circuit (both channels). • Give a reset command. • Close the STO circuit (both channels). • Reset any active faults. Restart the drive and check that the motor runs normally. • Open the 2nd input channel of the STO circuit. If the motor was running, it should coast to a stop. The drive generates an FA82 fault indication (see the firmware manual). • Give a start command to verify that the STO function blocks the drive's operation. The motor should not start. • Open the STO circuit (both channels). • Give a reset command. • Close the STO circuit (both channels). • Reset any active faults. Restart the drive and check that the motor runs normally. 	<input type="checkbox"/>
<p>Document and sign the validation test report which verifies that the safety function is safe and accepted for operation.</p>	<input type="checkbox"/>

Use

1. Open the activation switch, or activate the safety functionality that is wired to the STO connection.
2. The STO inputs on the drive control unit de-energize, and the control unit cuts off the control voltage from the output IGBTs.
3. The control program generates an indication as defined by parameter 31.22 (see the firmware manual of the drive).
4. The motor coasts to a stop (if running). The drive will not restart while the activation switch or safety relay contacts are open.
5. Deactivate the STO by closing the activation switch, or resetting the safety functionality that is wired to the STO connection.
6. Reset any faults before restarting.



WARNING!

The Safe torque off function does not disconnect the voltage of the main and auxiliary circuits from the drive. Therefore maintenance work on electrical parts of the drive or the motor can only be carried out after isolating the drive from the supply and all other voltage sources.



WARNING!

The drive cannot detect or memorize any changes in the STO circuitry when the drive control unit is not powered or when the main power to the drive is off. If both STO circuits are closed and a level-type start signal is active when the power is restored, it is possible that the drive starts without a fresh start command. Take this into account in the risk assessment of the system.

This is also valid when the drive is only powered by a BAPO-xx auxiliary power extension module.



WARNING!

Permanent magnet or synchronous reluctance [SynRM] motors only:

In case of a multiple IGBT power semiconductor failure, the drive can produce an alignment torque which maximally rotates the motor shaft by $180/p$ degrees (with permanent magnet motors) or $180/2p$ degrees (with synchronous reluctance [SynRM] motors) regardless of the activation of the Safe torque off function. p denotes the number of pole pairs.

Notes:

- If a running drive is stopped by using the Safe torque off function, the drive will cut off the motor supply voltage and the motor will coast to a stop. If this
-

causes danger or is not otherwise acceptable, stop the drive and machinery using the appropriate stop mode before activating the Safe torque off function.

- The Safe torque off function overrides all other functions of the drive.
 - The Safe torque off function is ineffective against deliberate sabotage or misuse.
 - The Safe torque off function has been designed to reduce the recognized hazardous conditions. In spite of this, it is not always possible to eliminate all potential hazards. The assembler of the machine must inform the final user about the residual risks.
-

Maintenance

After the operation of the circuit is validated at start-up, the STO function shall be maintained by periodic proof testing. In high demand mode of operation, the maximum proof test interval is 20 years. In low demand mode of operation, the maximum proof test interval is 10 years; see section [Safety data \(page 240\)](#). It is assumed that all dangerous failures of the STO circuit are detected by the proof test. To perform the proof test, do the [Validation test procedure \(page 234\)](#).

Note: See also the Recommendation of Use CNB/M/11.050 (published by the European co-ordination of Notified Bodies) concerning dual-channel safety-related systems with electromechanical outputs:

- When the safety integrity requirement for the safety function is SIL 3 or PL e (cat. 3 or 4), the proof test for the function must be performed at least every month.
- When the safety integrity requirement for the safety function is SIL 2 (HFT = 1) or PL d (cat. 3), the proof test for the function must be performed at least every 12 months.

The STO function of the drive does not contain any electromechanical components.

In addition to proof testing, it is a good practice to check the operation of the function when other maintenance procedures are carried out on the machinery.

Include the Safe torque off operation test described above in the routine maintenance program of the machinery that the drive runs.

If any wiring or component change is needed after start-up, or the parameters are restored, do the test given in section [Validation test procedure \(page 234\)](#).

Use only spare parts approved by ABB.

Record all maintenance and proof test activities in the machine logbook.

■ Competence

The maintenance and proof test activities of the safety function must be carried out by a competent person with adequate expertise and knowledge of the safety function as well as functional safety, as required by IEC 61508-1 clause 6.

Fault tracing

The indications given during the normal operation of the Safe torque off function are selected by drive control program parameter 31.22.

The diagnostics of the Safe torque off function cross-compare the status of the two STO channels. In case the channels are not in the same state, a fault reaction function is performed and the drive trips on an FA81 or FA82 fault. An attempt to use the STO in a non-redundant manner, for example activating only one channel, will trigger the same reaction.

See the firmware manual of the drive control program for the indications generated by the drive, and for details on directing fault and warning indications to an output on the control unit for external diagnostics.

Any failures of the Safe torque off function must be reported to ABB.

Safety data

The safety data for the Safe torque off function is given below.

Note: The safety data is calculated for redundant use, and applies only if both STO channels are used.

Frame size	SIL	SC	PL	SFF (%)	PFH ($T_1 = 20$ a) (1/h)	PFDavg ($T_1 = 2$ a)	PFDavg ($T_1 = 5$ a)	PFDavg ($T_1 = 10$ a)	MTTFD (a)	DC (%)	Cat.	HFT	CCF	T_M (a)	PFHdiag (1/h)	$\lambda_{Diag,s}$ (1/h)	$\lambda_{Diag,d}$ (1/h)	
1-phase $U_N = 230$ V																		
R0	3	3	e	>99	8.52E-09	7.43E-05	1.86E-04	3.72E-04	1968	≥90	3	1	80	20	6.29E-08	0.00E+00	9.51E-08	
R1	3	3	e	>99	8.52E-09	7.43E-05	1.86E-04	3.72E-04	1968	≥90	3	1	80	20	6.29E-08	0.00E+00	9.51E-08	
R2	3	3	e	>99	8.52E-09	7.43E-05	1.86E-04	3.72E-04	1968	≥90	3	1	80	20	6.29E-08	0.00E+00	9.51E-08	
3-phase $U_N = 230$ V																		
R1	3	3	e	>99	7.65E-09	6.71E-05	1.68E-04	3.36E-04	2210	≥90	3	1	80	20	6.29E-08	0.00E+00	9.51E-08	
R2	3	3	e	>99	7.65E-09	6.71E-05	1.68E-04	3.36E-04	2209	≥90	3	1	80	20	6.29E-08	0.00E+00	9.51E-08	
R3	3	3	e	>99	7.61E-09	6.68E-05	1.67E-04	3.34E-04	2569	≥90	3	1	80	20	6.29E-08	0.00E+00	9.51E-08	
R4	3	3	e	>99	7.61E-09	6.68E-05	1.67E-04	3.34E-04	2568	≥90	3	1	80	20	6.29E-08	0.00E+00	9.51E-08	
3-phase $U_N = 400/480$ V																		
R1	3	3	e	>99	7.65E-09	6.71E-05	1.68E-04	3.36E-04	2210	≥90	3	1	80	20	6.29E-08	0.00E+00	9.51E-08	
R2	3	3	e	>99	7.65E-09	6.71E-05	1.68E-04	3.36E-04	2209	≥90	3	1	80	20	6.29E-08	0.00E+00	9.51E-08	
R3	3	3	e	>99	7.61E-09	6.68E-05	1.67E-04	3.34E-04	2569	≥90	3	1	80	20	6.29E-08	0.00E+00	9.51E-08	
R4	3	3	e	>99	7.61E-09	6.68E-05	1.67E-04	3.34E-04	2568	≥90	3	1	80	20	6.29E-08	0.00E+00	9.51E-08	
																	3AXD10001401865 E	

- The STO is a type A safety component as defined in IEC 61508-2.
- Relevant failure modes:
 - The STO trips spuriously (safe failure)
 - The STO does not activate when requested
 - A fault exclusion on the failure mode “short circuit on printed circuit board” has been made (EN 13849-2, table D.5). The analysis is based on an assumption that one failure occurs at one time. No accumulated failures have been analyzed.
- STO response times:
 - STO reaction time (shortest detectable break): 1 ms
 - STO response time: 5 ms (typical), 15 ms (maximum)
 - Fault detection time: Channels in different states for longer than 200 ms
 - Fault reaction time: Fault detection time + 10 ms.
- Indication delays:
 - STO fault indication (parameter 31.22) delay: < 500 ms
 - STO warning indication (parameter 31.22) delay: < 1000 ms.

■ **Terms and abbreviations**

Term or abbreviation	Reference	Description
Cat.	EN ISO 13849-1	Classification of the safety-related parts of a control system in respect of their resistance to faults and their subsequent behavior in the fault condition, and which is achieved by the structural arrangement of the parts, fault detection and/or by their reliability. The categories are: B, 1, 2, 3 and 4.
CCF	EN ISO 13849-1	Common cause failure (%)
DC	EN ISO 13849-1	Diagnostic coverage (%)
HFT	IEC 61508	Hardware fault tolerance
MTTF _D	EN ISO 13849-1	Mean time to dangerous failure: (Total number of life units) / (Number of dangerous, undetected failures) during a particular measurement interval under stated conditions
PFD _{avg}	IEC 61508	Average probability of dangerous failure on demand, that is, mean unavailability of a safety-related system to perform the specified safety function when a demand occurs

Term or abbreviation	Reference	Description
PFH	IEC 61508	Average frequency of dangerous failures per hour, that is, average frequency of a dangerous failure of a safety related system to perform the specified safety function over a given period of time
PFH _{diag}	IEC/EN 62061	Average frequency of dangerous failures per hour for the diagnostic function of STO
PL	EN ISO 13849-1	Performance level. Levels a...e correspond to SIL
Proof test	IEC 61508, IEC 62061	Periodic test performed to detect failures in a safety-related system so that, if necessary, a repair can restore the system to an "as new" condition or as close as practical to this condition
SC	IEC 61508	Systematic capability (1...3)
SFF	IEC 61508	Safe failure fraction (%)
SIL	IEC 61508	Safety integrity level (1...3)
STO	IEC/EN 61800-5-2	Safe torque off
T_1	IEC 61508-6	Proof test interval. T_1 is a parameter used to define the probabilistic failure rate (PFH or PFD) for the safety function or subsystem. Performing a proof test at a maximum interval of T_1 is required to keep the SIL capability valid. The same interval must be followed to keep the PL capability (EN ISO 13849) valid. See also section Maintenance.
T_M	EN ISO 13849-1	Mission time: the period of time covering the intended use of the safety function/device. After the mission time elapses, the safety device must be replaced. Note that any T_M values given cannot be regarded as a guarantee or warranty.
λ_{Diag_d}	IEC 61508-6	Dangerous failure rate (per hour) of the diagnostics function of STO
λ_{Diag_s}	IEC 61508-6	Safe failure rate (per hour) of the diagnostics function of STO

■ TÜV certificate

The TÜV certificate is available on the Internet.

16

BAPO-01 auxiliary power extension module

Contents of this chapter

This chapter contains a description and technical data of the optional BAPO-01 auxiliary power extension module.

Safety instructions

**WARNING!**

Obey the safety instructions of the drive. If you ignore them, injury or death, or damage to the equipment can occur.

Hardware description

The BAPO-01 auxiliary power extension module (option +L534) lets you use an external 24 V DC power supply with the drive. An external power supply is used to keep the drive control board energized during a power outage.

The BAPO-01 module has internal connections to provide back-up power to the control board (I/O, fieldbus). There is a DC to DC flyback converter power supply inside the module. This power supply takes 24 V DC as input and outputs 5 V DC to the control board to keep the processor and communication links on at all times.

Note: The BAPO-01 is not a battery.

If you change drive parameters when the control board is energized by the BAPO-01 module, force parameter saving by setting the value of parameter 96.07 Parameter save manually to (1) Save. Otherwise, changed data will not be saved.

■ **Layout**

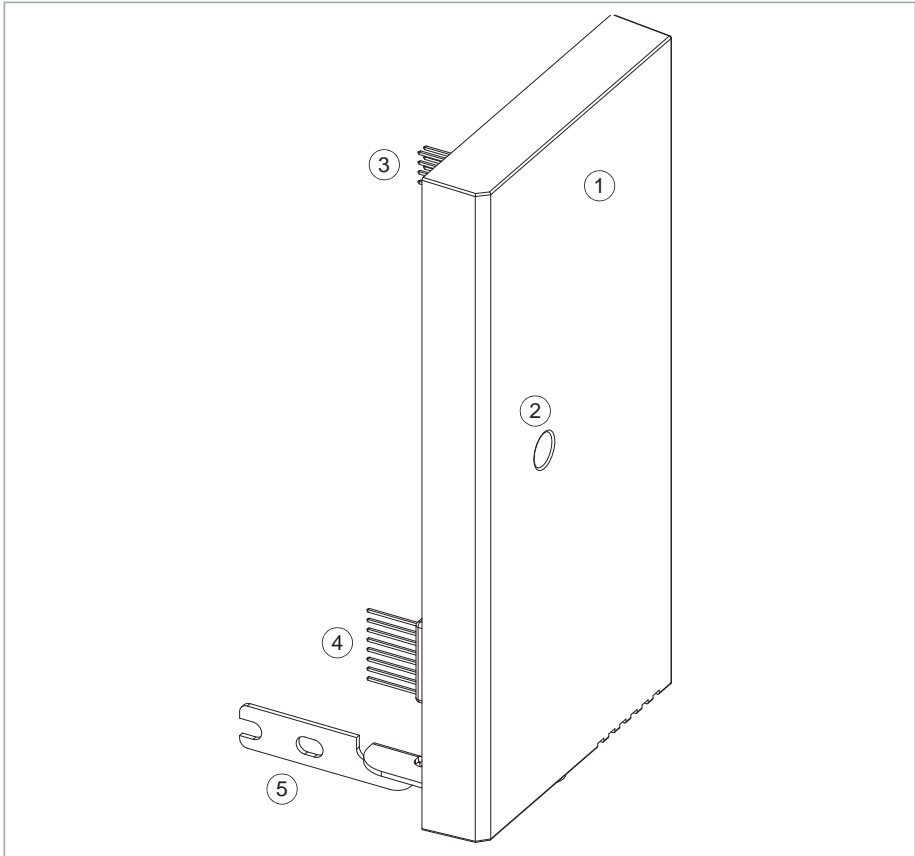

1	BAPO-01 module
2	Locking screw hole
3	Internal X100 connector
4	Internal X102 connector
5	Grounding rail

Mechanical installation

Refer to [Installing options \(page 86\)](#) and [BAPO, BREL, BRES, and BTAC modules quick installation guide \(3AXD50000837946 \[English\]\)](#).

Electrical installation

Connect the external power supply to the +24 V and DGND terminals on the drive. See the electrical installation instructions of the drive.

Do not chain an external 24 V DC power supply to several drives. Each drive must be powered by a single 24 V DC power supply, or a separate 24 V DC output of one auxiliary power source.

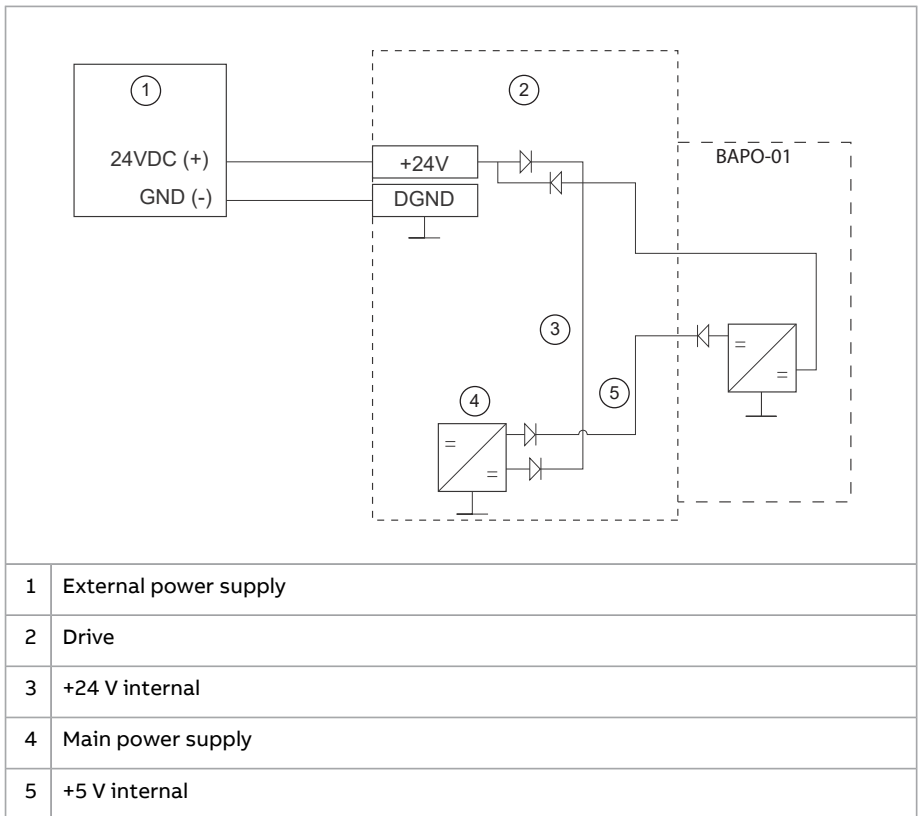

Start-up

To configure the BAPO-01 module:

1. Power up the drive.
2. Set the parameter 95.04 Control board supply to 1 (External 24V).

Technical data

Voltage and current rating for the auxiliary power supply: +24 V DC $\pm 10\%$, max. 1000 mA (including internal fan load).

Power loss: Power losses with maximum load 4 W.

Dimensions:

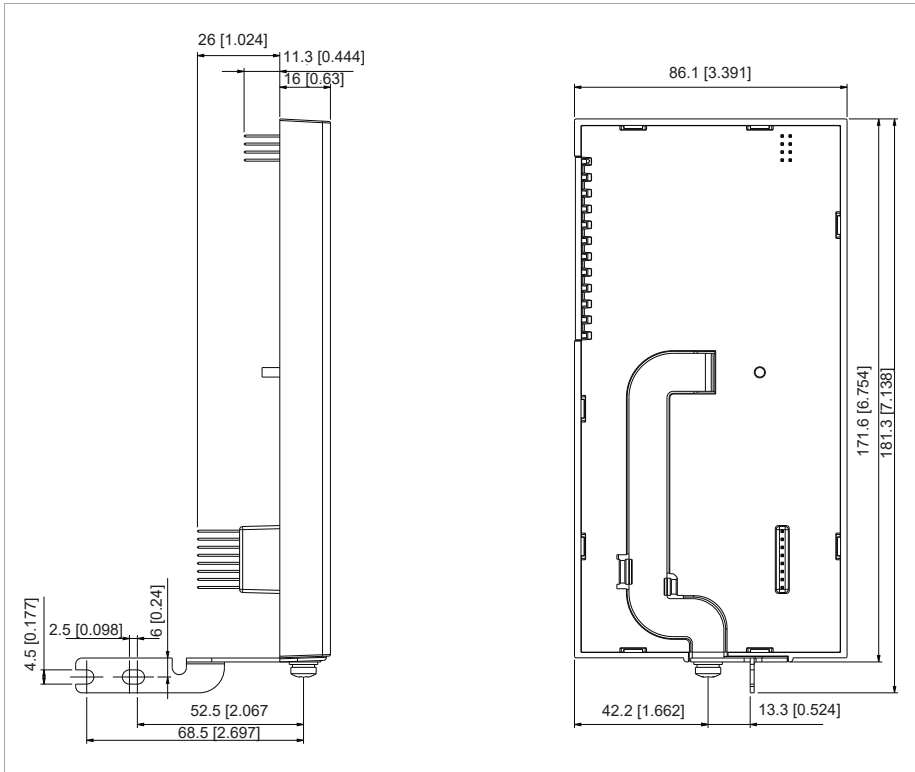

17

BIO-01 I/O extension module

Contents of this chapter

This chapter contains a description and technical data of the optional BIO-01 I/O extension module.

Safety instructions

**WARNING!**

Obey the safety instructions of the drive. If you ignore them, injury or death, or damage to the equipment can occur.

Hardware description

■ Product overview

BIO-01 (option +L515) is an I/O extension module to be used with a fieldbus adapter module. The BIO-01 module is installed between the drive and the fieldbus module.

BIO-01 has two digital inputs (DI4, DI5) and one analog input (AI). It also has two terminals (S1, S2) that can be configured with the switches on the module. S1 can be configured as analog output (AO1) or digital output (DO1). S2 can be configured as digital output (DO1) or digital input (DI3).

■ **Layout**

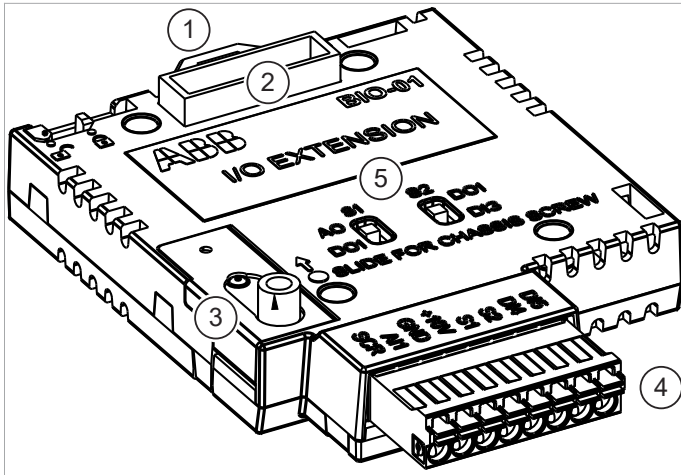

- 1. Locking tab
- 2. Option module slot
- 3. Chassis screw
- 4. I/O connector
- 5. Switches for configuring terminals S1 and S2

Mechanical installation

See the electrical installation instructions of the drive.

Before you install the BIO-01 option module, make sure that the chassis screw slider is in the top position. After the option module is installed, tighten the chassis screw and move the slider to the bottom position.

The BIO-01 option module kit comes with a higher cable clamp plate. Use this cable clamp plate to ground the wires that connect to the BIO-01 option module.

Terminal configuration

You must configure terminals S1 and S2 before you install the fieldbus module. Refer to the table that follows for the possible configurations:

Setting		Result		
Switch S1	Switch S2	Terminal S1 functions as	Terminal S2 functions as	Supported configuration
DO1 (default)	DI3 (default)	Digital output DO1	Digital input DI3	Yes
AO1	DI3 (default)	Analog output AO1	Digital input DI3	Yes
AO1	DO1	Analog output AO1	Digital output DO1	Yes
DO1 (default)	DO1	-	-	No

If you change the switch configuration while the drive is powered on, the drive will trip on a fault. Also, an unsupported configuration will cause the drive to trip on a fault.

Electrical installation

The BIO-01 module has removable spring clamp terminals. Use ferrules on the multistranded conductor ends.

The connection diagram below is applicable to drives with the BIO-01 I/O extension module when the ABB standard macro is selected (parameter 96.04).

Connection	Terminal	Description	1)	
	+24 V	Auxiliary voltage output +24 V DC, max. 250 mA	×	
	DGND	Auxiliary voltage output common	×	
	DCOM	Digital input common for all	×	
	DI1	Stop (0) / Start (1)	×	
	DI2	Forward (0) / Reverse (1)	×	
	S2 (DI3)	Constant frequency/speed selection		
	DI4	Constant frequency/speed selection		
	DI5	Ramp set 1 (0) / Ramp set 2 (1)		
	DO1	S1 (DO1)	Not configured (DIO1)	
	AI1	AI1	Output frequency/speed ref: 0 ... 10 V DC	
	+10V	+10V	Reference voltage +10 V DC (max. 10 mA)	
	GND	GND	Analog circuit common / DO common	
	SCR	SCR	Signal cable shield	
	SGND	IN1	Safe torque off. Both IN1 and IN2 circuits must be closed for the drive to start. (Factory connection.)	×
	IN1	IN1		×
	IN2	IN2		×
	OUT1	OUT1		×

1) × = on base unit, blank = on BIO-01 module.

Start-up

The BIO-01 module is automatically identified by the drive firmware. To configure the inputs and outputs, refer to the drive firmware manual.

Technical data

Control connection data: Spring type terminal blocks. Conductor size accepted by the terminals: 0.2 ... 1.5 mm² (24 ... 16 AWG). Exception: max. 0.75 mm² (18 AWG) for a multistranded conductor with a ferrule and plastic sleeve.

Internal connections of GND and SCR terminals

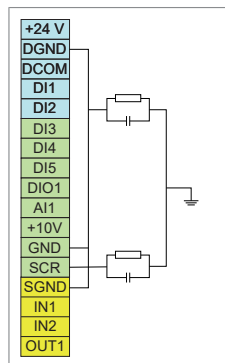

Dimensions

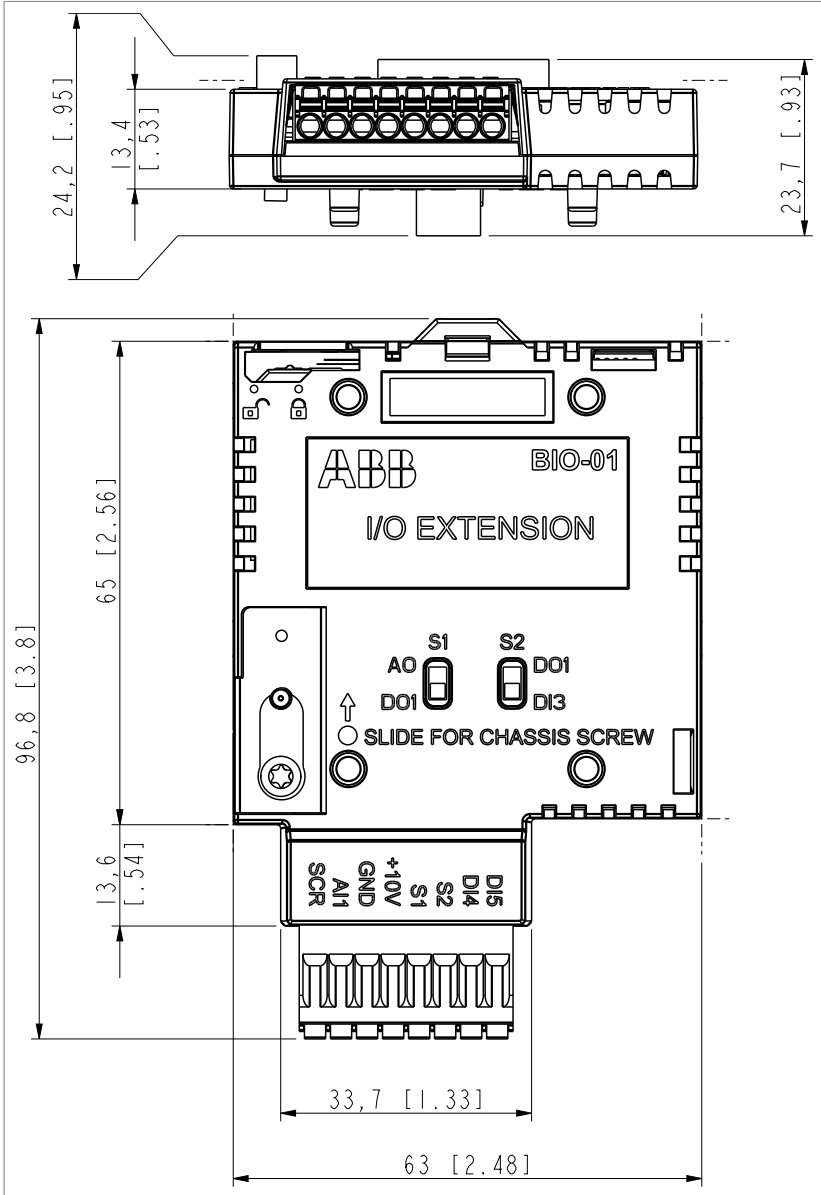

18

BREL-01 relay output extension module

Contents of this chapter

This chapter contains a description and technical data of the optional BREL-01 relay output extension module.

Safety instructions



WARNING!

Obey the safety instructions of the drive. If you ignore them, injury or death, or damage to the equipment can occur.

Hardware description

■ Product overview

BREL-01 relay output extension module (option +L511) adds four relay outputs to the drive.

■ **Layout**

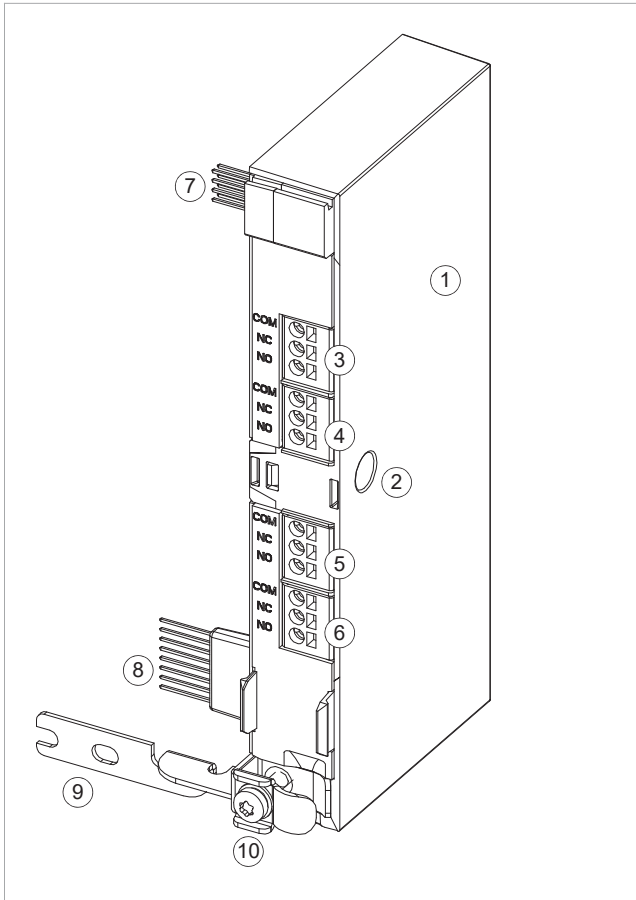

- 1. BREL-01 module
- 2. Locking screw hole
- 3. X103 connector
- 4. X104 connector
- 5. X105 connector
- 6. X106 connector
- 7. Internal X100 connector
- 8. Internal X102 connector
- 9. Grounding rail
- 10. Grounding screw

Mechanical installation

Refer to [Installing options \(page 86\)](#) and [BAPO, BREL, BRES, and BTAC modules quick installation guide \(3AXD50000837946 \[English\]\)](#).

Electrical installation

Use 0.5 ... 2.5 mm² (20 ... 14 AWG) cable with a sufficient voltage rating.

If you connect an inductive load (relay or contactor coil, motor) protect the relay contacts with a varistor, RC filter (AC) or diode (DC). Install the protective component as close to the inductive load as possible. Do not install protective components at the relay output terminals.

Identification			Description
X103	4		Relay outputs RO4...RO7: Max. switching voltage: 250 V AC / 30 V DC Max. switching current: 2 A Galvanically isolated.
1	COM	Common	
2	NC	Normally closed	
3	NO	Normally open	
X104	5		
1	COM	Common	
2	NC	Normally closed	
3	NO	Normally open	
X105	6		
1	COM	Common	
2	NC	Normally closed	
3	NO	Normally open	
X106	7		
1	COM	Common	
2	NC	Normally closed	
3	NO	Normally open	

Start-up

To configure the operation of the relays added with the BREL-01 module:

1. Power up the drive.
2. Set the parameter 15.01 Extension module type to 5 (BREL).
3. Use the control panel on the drive and set the parameters for relay outputs RO4...RO7 in 15 I/O extension module. Refer to the [ACS480 standard control program firmware manual \(3AXD50000047399 \[English\]\)](#) for parameter descriptions.

Configuration parameters

The configuration parameters of the BREL-01 module are in group 15 I/O extension module.

No.	Name/Value	Description	Def / FbEq16/32
15 I/O extension module			

258 BREL-01 relay output extension module

No.	Name/Value	Description	Def / FbEq16/32
15.01	Extension module type	Activates (and specifies the type of) I/O extension module.	None
	BREL	External relay option BREL-01.	5
15.02	Detected extension module	I/O extension module detected on the drive.	None
	BREL	External relay option BREL-01.	5
15.04	RO status	Displays the status of the relay outputs. This parameter is read-only.	1 = 1
	Bit 0 RO4	1 = Relay output 4 is ON.	-
	Bit 1 RO5	1 = Relay output 5 is ON.	-
	Bit 2 RO6	1 = Relay output 6 is ON.	-
	Bit 3 RO7	1 = Relay output 7 is ON.	-
15.05	RO force selection	The electrical statuses of the relay/digital outputs can be overridden for e.g. testing purposes. A bit in parameter 15.06 RO forced data is provided for each relay or digital output, and its value is applied whenever the corresponding bit in this parameter is 1.	1 = 1
	Bit 0 RO4	1 = Force relay output 4 to value of bit 0 of parameter 15.06 RO forced data.	-
	Bit 1 RO5	1 = Force relay output 5 to value of bit 0 of parameter 15.06 RO forced data.	-
	Bit 2 RO6	1 = Force relay output 6 to value of bit 0 of parameter 15.06 RO forced data.	-
	Bit 3 RO7	1 = Force relay output 7 to value of bit 0 of parameter 15.06 RO forced data.	-
15.06	RO forced data	Allows the data value of a forced relay or digital output to be changed from 0 to 3.	1 = 1
	Bit 0 RO4	Force the value of this bit to RO4, if so defined in parameter 15.05 RO force selection.	-
	Bit 1 RO5	Force the value of this bit to RO5, if so defined in parameter 15.05 RO force selection.	-
	Bit 2 RO6	Force the value of this bit to RO6, if so defined in parameter 15.05 RO force selection.	-
	Bit 3 RO7	Force the value of this bit to RO7, if so defined in parameter 15.05 RO force selection.	-

No.	Name/Value	Description	Def / FbEq16/32
15.07	RO4 source	Selects a drive signal to be connected to relay output RO4.	Not energized
	Not energized	Output is not energized.	0
	Energized	Output is energized.	1
	For the complete parameter list, refer to the drive firmware manual.		...
15.08	RO4 ON delay	Defines the activation delay for relay output RO4.	0.0 s
	0.0 ... 3000.0 s	Activation delay for RO4.	10 = 1 s
15.09	RO4 OFF delay	Defines the deactivation delay for relay output RO4.	0.0 s
	0.0 ... 3000.0 s	Deactivation delay for RO4.	10 = 1 s
15.10	RO5 source	Selects a drive signal to be connected to relay output RO5.	Not energized
	Not energized	Output is not energized.	0
	Energized	Output is energized.	1
	For the complete parameter list, refer to the drive firmware manual.		...
15.11	RO5 ON delay	Defines the activation delay for relay output RO5.	0.0 s
	0.0 ... 3000.0 s	Activation delay for RO5.	10 = 1 s
15.12	RO5 OFF delay	Defines the deactivation delay for relay output RO5.	0.0 s
	0.0 ... 3000.0 s	Deactivation delay for RO5.	10 = 1 s
15.13	RO6 source	Selects a drive signal to be connected to relay output RO6.	Not energized
	Not energized	Output is not energized.	0
	Energized	Output is energized.	1
	For the complete parameter list, refer to the drive firmware manual.		...
15.14	RO6 ON delay	Defines the activation delay for relay output RO6.	0.0 s
	0.0 ... 3000.0 s	Activation delay for RO6.	10 = 1 s
15.15	RO6 OFF delay	Defines the deactivation delay for relay output RO6.	0.0 s
	0.0 ... 3000.0 s	Deactivation delay for RO6.	10 = 1 s
15.16	RO7 source	Selects a drive signal to be connected to relay output RO7.	Not energized
	Not energized	Output is not energized.	0
	Energized	Output is energized.	1
	For the complete parameter list, refer to the drive firmware manual.		...

260 BREL-01 relay output extension module

No.	Name/Value	Description	Def / FbEq16/32
15.17	RO7 ON delay	Sets the activation delay for relay output 7.	0.0 s
	0.0...3000.0 s	Activation delay for relay output 7.	10 = 1 s
15.18	RO7 OFF delay	Sets the deactivation delay for relay output 7.	0.0 s
	0.0...3000.0 s	Deactivation delay for relay output 7.	10 = 1 s

Technical data

External connectors: Four 3-pin (1×3) spring-clamp type terminal blocks, tin plated, 2.5 mm² (14 AWG) wire size, pitch 5.0 mm.

Internal connectors: Connector X102 provides relay control signals from the control board: 1×8 pin header, pitch 2.54 mm, height 33.53 mm. Connector X100 is not in use in BREL-01: 2×4 pin header, pitch 2.54 mm, height 15.75 mm.

Dimensions:

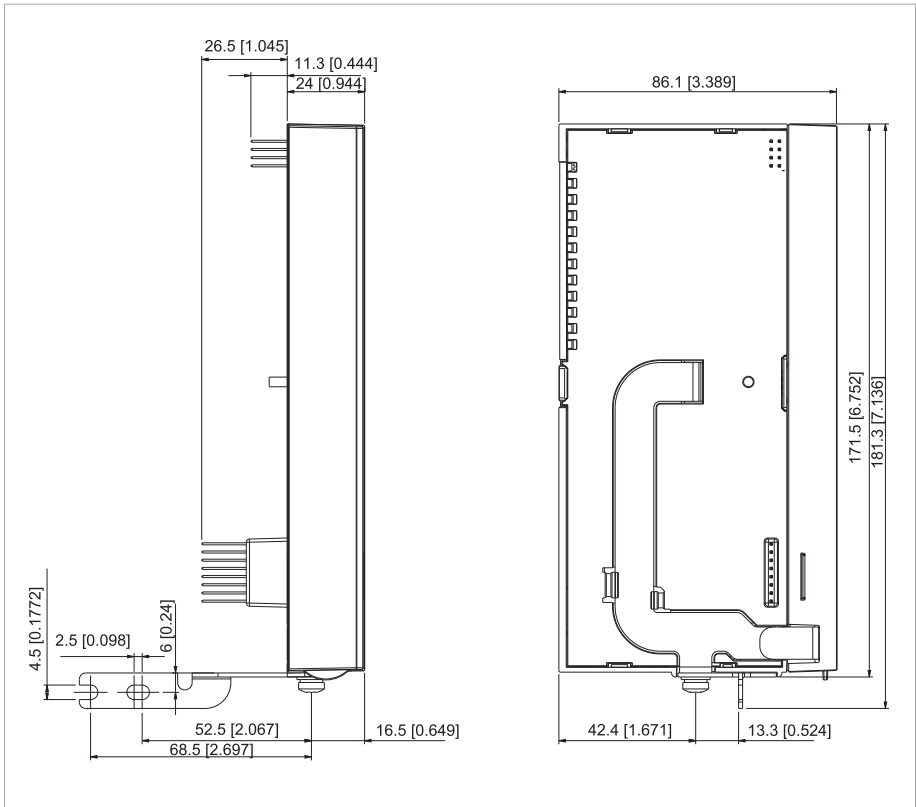

Further information

Product and service inquiries

Address any inquiries about the product to your local ABB representative, quoting the type designation and serial number of the unit in question. A listing of ABB sales, support and service contacts can be found by navigating to www.abb.com/contact-centers.

Product training

For information on ABB product training, navigate to new.abb.com/service/training.

Providing feedback on ABB manuals

Your comments on our manuals are welcome. Navigate to forms.abb.com/form-26567.

Document library on the Internet

You can find manuals and other product documents in PDF format on the Internet at www.abb.com/drives/documents.



www.abb.com/drives



3AXD50000047392F