

ACS380 drives

Quick installation and start-up guide



Safety instructions

WARNING! Obey these instructions. If you ignore them, injury or death, or damage to the equipment can occur. If you are not a qualified electrical professional, do not do electrical installation or maintenance work.

- Do not do work on the drive, motor cable, motor, or control cables when the drive is connected to the input power. Before you start the work, isolate the drive from all dangerous voltage sources and make sure that it is safe to start the work. Always wait for 5 minutes after disconnecting the input power to let the intermediate circuit capacitors discharge.
- Do not do work on the drive when a rotating permanent magnet motor is connected to it. A rotating permanent magnet motor energizes the drive, including its input and output terminals.

1. Unpack the delivery

Keep the drive in its package until you are ready to install it. After unpacking, protect the drive from dust, debris and moisture.

Make sure that these items are included:

- drive
- options, if ordered with an option code
- installation accessories (cable clamps, cable ties, hardware, etc.)
- mounting template (frames R3 and R4 only)
- safety instructions
- multilingual warning sticker sheet (residual voltage warning)
- user interface guide (under the drive front cover)
- quick installation and start-up guide
- hardware and firmware manuals, if ordered with an option code.

Make sure that there are no signs of damage to the items.

2. Reform the capacitors

If the drive has not been powered up for a year or more, you must reform the DC link capacitors. The manufacturing date is on the type designation label. Refer to [Capacitor reforming instructions \(3BFE64059629 \[English\]\)](#).

3. Select the cables and fuses

- Select the power cables. Obey the local regulations.
 - Input power cable:** ABB recommends to use symmetrical shielded cable (VFD cable) for the best EMC performance.
 - Motor cable:** Use symmetrical shielded cable (VFD cable) for the best EMC performance. Symmetrical shielded cable also reduces bearing currents, wear, and stress on motor insulation.
 - Power cable types:** In IEC installations, use copper or aluminum cables (if permitted). In UL installations, use only copper cables.
 - Current rating:** max. load current.
 - Voltage rating:** min. 600 V AC.
 - Temperature rating:** In IEC installations, select a cable rated for at least 70 °C (158 °F) maximum permissible temperature of conductor in continuous use. In UL installations, select a cable rated for at least 75 °C (167 °F).
 - Size:** Refer to [Fuses and typical power cable sizes](#) for the typical cable sizes and to [Terminal data for the power cables](#) for the maximum cable sizes.
- Select the control cables. Use double-shielded twisted-pair cable for analog signals. Use double-shielded or single-shielded cable for the digital, relay and I/O signals. Do not run 24 V and 115/230 V signals in the same cable.
- Protect the drive and input power cable with the correct fuses. Refer to [Fuses and typical power cable sizes](#).

4. Examine the installation area

The drive is intended for cabinet installation and has a degree of protection of IP20 / UL open type as standard.

Examine the site where you will install the drive. Make sure that:

- The installation site is sufficiently ventilated and hot air does not recirculate.
- There is sufficient free space around the drive for cooling, maintenance, and operation. For the minimum free space requirements, refer to [Free space requirements](#).
- The ambient conditions meet the requirements. Refer to [Ambient conditions](#).
- The installation surface is as close to vertical as possible and strong enough to support the weight of the drive. Refer to [Dimensions and weights](#).
- The installation surface, floor and materials near the drive are not flammable.
- There are no sources of strong magnetic fields such as high-current single-core conductors or contactor coils near the drive. A strong magnetic field can cause interference or inaccuracy in the operation of the drive.

5. Install the drive

You can install the drive with screws, or to a DIN rail (top hat type, width x height = 35 mm x 7.5 mm [1.4 in x 0.3 in]).

- Install R0 drives vertically. R0 drives do not have a cooling fan.
- You can install drives with frame size R1...R4 tilted by a maximum of 90 degrees, from vertical to fully horizontal orientation.
- Do not install the drive upside down.
- You can install several drives side by side.

To install the drive with screws

- Make marks onto the surface for the mounting holes. Refer to [Dimensions and weights](#). Use the included mounting template for frames R3 and R4.
- Drill the holes for the mounting screws. If necessary, install suitable plugs or anchors into the holes.
- Install the mounting screws into the holes. Leave a gap between the screw head and installation surface.
- Put the drive onto the mounting screws.
- Tighten the mounting screws.

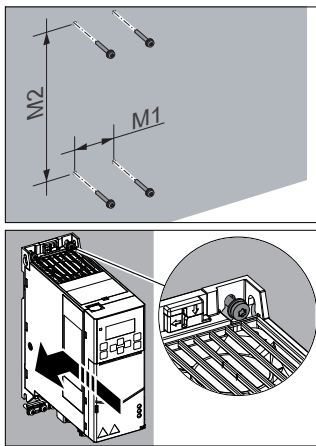

To install the drive to a DIN rail

- Move the locking part to the left. If necessary, use a flat-head screwdriver.
- Push and hold the locking button down.
- Put the top tabs of the drive onto the top edge of the DIN rail.
- Put the drive against the bottom edge of the DIN rail.
- Release the locking button.
- Move the locking part to the right.
- Make sure that the drive is correctly installed.

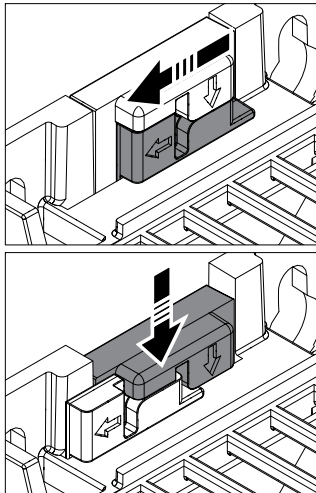

To remove the drive, open the locking part and lift the drive from the DIN rail.

6. Measure the insulation resistance

Drive: Do not do voltage tolerance or insulation resistance tests on the drive, because this can cause damage to the drive.

Input power cable: Before you connect the input power cable, measure the insulation of the input power cable. Obey the local regulations.

Motor and motor cable:

- Make sure that the motor cable is connected to the motor and disconnected from the drive output terminals T1/U, T2/V and T3/W.
- Use a voltage of 1000 V DC to measure the insulation resistance between each phase conductor and the protective earth conductor. The insulation resistance of an ABB motor must be more than 100 Mohm (at 25 °C [77 °F]). For the insulation resistance of other motors, refer to the manufacturer's documentation. Moisture in the motor decreases the insulation resistance. If you think that there is moisture in the motor, dry the motor and do the measurement again.

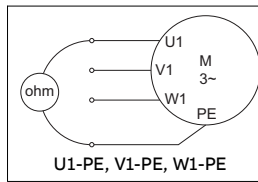

7. Make sure that the drive is compatible with the grounding system

You can connect all drive types to a symmetrically grounded TN-S system (center-grounded wye). The drive is delivered with the EMC and VAR screws installed. The material of the screws (plastic or metal) depends on the product variant. The table shows when to remove the metal EMC screw (disconnect the internal EMC filter) or metal VAR screw (disconnect the varistor circuit).

Screw label	Factory default screw material	Grounding systems		
		Symmetrically grounded TN-S systems (center-grounded wye)	Corner-grounded delta, midpoint-grounded delta and TT systems	IT systems (ungrounded or high-resistance grounded)
EMC	Metal	Do not remove	Remove	Remove
	Plastic ¹⁾	Do not remove ²⁾	Do not remove	Do not remove
VAR	Metal	Do not remove	Do not remove	Remove
	Plastic	Do not remove	Do not remove	Do not remove

1) Drives sold in North America have a plastic EMC screw.

2) Can install the metal screw (included in the drive delivery) to connect the internal EMC filter.

8. Connect the power cables

Connection diagram (shielded cables)

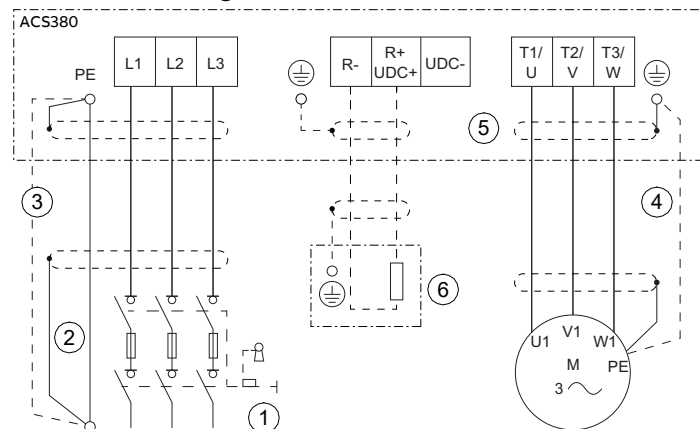

- Disconnecting device.
- Two protective earth (ground) conductors. Drive safety standard IEC/EN 61800-5-1 requires two PE conductors, if the cross-sectional area of the PE conductor is less than 10 mm² Cu or 16 mm² Al. For example, you can use the cable shield in addition to the fourth conductor.
- Use a separate grounding cable or a cable with a separate PE conductor for the line side, if the conductivity of the fourth conductor or shield does not meet the requirements for the PE conductor.
- Use a separate grounding cable for the motor side, if the conductivity of the shield is not sufficient, or if there is no symmetrically constructed PE conductor in the cable.
- 360-degree grounding of the cable shield is required for the motor cable and brake resistor cable (if used). It is also recommended for the input power cable.
- Brake resistor and resistor cable (optional).

Connection procedure (shielded cables)

For the tightening torques, refer to [Terminal data for the power cables](#).

- Remove the screw on the drive front cover, then remove the front cover.
- Attach the residual voltage warning sticker in the local language to the drive.
- Strip the motor cable.
- Ground the motor cable shield under the grounding clamp.
- Twist the motor cable shield into a bundle, mark it and connect it to the grounding terminal.
- Connect the phase conductors of the motor cable to terminals T1/U, T2/V and T3/W.
- If you use a brake resistor, connect the brake resistor cable to terminals R- and UDC+. Use a shielded cable and ground the shield under the grounding clamp.
- Make sure that the R- and UDC+ terminal screws are tightened. Do this step also if you do not connect cables to the terminals.
- Strip the input power cable.
- If the input power cable has a shield, ground the shield under the grounding clamp. Then twist the shield into a bundle, mark it and connect it to the grounding terminal.
- Connect the PE conductor of the input power cable to the grounding terminal. If necessary, use a second PE conductor.
- In 3-phase drives, connect the phase conductors of the input power cable to terminals L1, L2 and L3. In 1-phase drives, connect the phase and neutral conductors to terminals L1 and L2.
- Mechanically attach the cables on the outside of the drive.

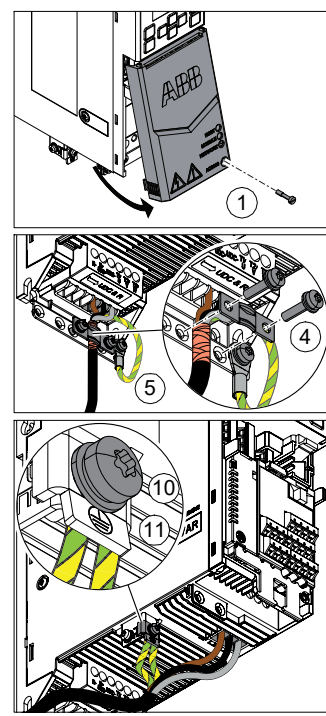

9. Connect the control cables

Do the connections according to the default control connections of the application macro that you select. Keep the signal wire pairs twisted as near to the terminals as possible to prevent inductive coupling. The tightening torque for the terminal connections is 0.5 ... 0.6 N·m (4.4 ... 5.3 lbf·in).

- Strip a part of the outer shield of the control cable for grounding.
- Use a cable tie to ground the outer shield to the grounding tab.
- Use metal cable ties for 360-degree grounding.
- Strip the control cable conductors.
- Connect the conductors to the correct control terminals.
- Connect the shields of the twisted pairs and grounding wires to the SCR terminal.
- Mechanically attach the control cables on the outside of the drive.

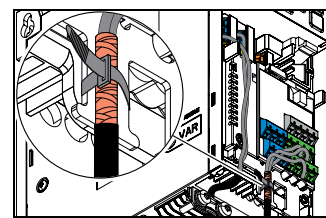

Default I/O connections (ABB standard macro)

The ABB standard macro is the default macro. The connection diagram for the ABB standard macro is shown below. If you have a drive variant that does not have the BMIO-01 module, connect only the terminals that are on the base unit.

Terminal	Description	1)
1...10 kohm	Analog inputs and outputs	
AI1	Frequency/speed reference (0 ... 10 V)	
AGND	Analog input circuit common	
AI2	Not configured	
AGND	Analog input circuit common	
AO	Output frequency (0 ... 20 mA)	
AGND	Analog input circuit common	
SCR	Signal cable shield	
+10 V	Reference voltage	
	Digital I/O connections	
+24 V	Aux. voltage output +24 V DC, max. 250 mA	x
DGND	Aux. voltage output common	x
DCOM	Digital input common	x
DI1	Stop (0) / Start (1)	x
DI2	Forward (0) / Reverse (1)	x
DI3	Speed selection	
DI4	Speed selection	
DIO1	Ramp 1 (0) / Ramp 2 (1)	
DIO2	Ready (0) / Not ready (1)	
DIO SRC	Digital output auxiliary voltage	
DIO COM	Digital input/output common	
	Relay output 1	
RC	No fault [Fault (-1)]	x
RA		x
RB		x
	Safe torque off (STO)	
S+	Safe torque off (STO). Both circuits must be closed for the drive to start. The drawing shows the simplified connection of a safety circuit through safety contacts. If STO is not used, leave the factory-installed jumpers in place. See also section Safe torque off (STO) .	x
SGND		x
S1		x
S2		x

1) x = on base unit, empty = on BMIO-01 module.

Embedded fieldbus connection

You can connect the drive to an EIA-485 serial communication link through the embedded fieldbus interface on the BMIO-01 I/O module. The embedded fieldbus interface supports the Modbus RTU protocol.

To configure Modbus RTU communication with the embedded fieldbus:

- Connect the fieldbus cables and the necessary I/O signals.
- Use the jumpers to set the termination and bias settings.
- Power up the drive and set the necessary parameters.

A connection example is shown below.

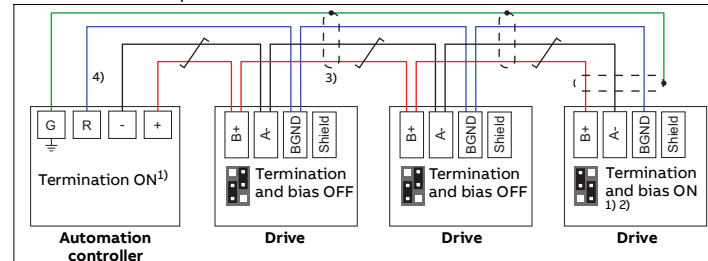

- The devices at the ends of the fieldbus must have termination on. All other devices must have termination off.
- One device must have bias on. It is recommended that this device is at the end of the fieldbus.
- Attach the cable shields together at each drive, but do not connect them to the drive. Connect the shields only to the grounding terminal in the automation controller.
- Connect the signal ground (BGND) conductor to the signal ground reference terminal in the automation controller. If the automation controller does not have a signal ground reference terminal, you can connect the signal ground to the cable shields through a 100 ohm resistor, preferably near the controller.

10. Start up the drive

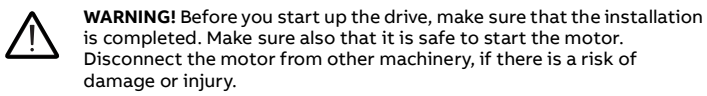

For information on the user interface, refer to the [ACS380 User interface guide \(3AXD5000022224 \[English\]\)](#), which is delivered with the drive.

- Power up the drive. The drive software automatically identifies the connected adapter (BMIO-01 module or some of the fieldbus modules) and sets the applicable parameters.
- Select the units (international or US). In the Motor data view, select the motor type:
 - AsynM:** Asynchronous motor
 - PMSM:** Permanent magnet synchronous motor
 - SynRM:** Synchronous reluctance motor.
- Set the motor control mode:
 - Vector:** Speed reference. This is suitable for most cases.
 - Scalar:** Frequency reference. Do not use this mode for permanent magnet synchronous motors. Use this mode when:
 - The number of motors can change.
 - The nominal motor current is less than 20% of the nominal drive current.
- Set the nominal motor values.
- Start the motor and check the direction of rotation. If the direction is incorrect, you can:
 - change the **Phase order** setting, or
 - change the phase order of the motor cable.

Note: In vector control mode the drive does an automatic standstill ID run at the first start.
- In the Motor control view, set the start and stop mode.
- Set the acceleration and deceleration times.
- Set the maximum and minimum speeds.
- In the Control macros view, select the applicable macro. To configure fieldbus communications, refer to [Fieldbus communication](#).
- Tune the drive parameters to the application. You can also use an assistant control panel (ACS-AP-...) or the Drive Composer PC tool.

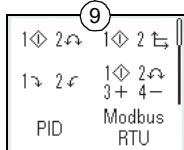
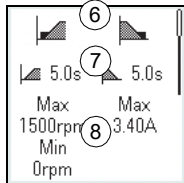
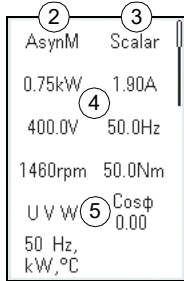

ACS380-04xx-...	Input ratings			Output ratings																		
	No choke	With choke	Max. current	Nominal use				Light-duty use				Heavy-duty use										
	I_A	I_A	I_{max}	I_N	P_N	I_{Ld}	P_{Ld}	I_{Hd}	P_{Hd}	I_A	P_A	I_{Hd}	P_{Hd}	I_A	P_A	I_{Hd}	P_{Hd}					
25A0-2	30.5	25.0	31.5	25.0	5.5	24.2	5.5	7.5	17.5	4.0	5.0	30.5	25.0	31.5	25.0	5.5	24.2	5.5	7.5	17.5	4.0	5.0
033A-2	37.5	32.0	45.0	32.0	7.5	30.8	7.5	10.0	25.0	5.5	7.5	37.5	32.0	45.0	32.0	7.5	30.8	7.5	10.0	25.0	5.5	7.5
032A-2	37.4	32.0	45.0	32.0	7.5	30.8	7.5	10.0	25.0	5.5	7.5	37.4	32.0	45.0	32.0	7.5	30.8	7.5	10.0	25.0	5.5	7.5
048A-2	53.2	48.0	57.6	48.0	11.0	46.2	11.0	15.0	32.0	7.5	10.0	53.2	48.0	57.6	48.0	11.0	46.2	11.0	15.0	32.0	7.5	10.0
055A-2	60.0	55.0	86.4	55.0	15.0	52.8	15.0	15.0	48.0	11.0	15.0	60.0	55.0	86.4	55.0	15.0	52.8	15.0	15.0	48.0	11.0	15.0
3-phase $U_N = 400$ V																						
01A8-4	2.8	1.8	2.2	1.8	0.55	1.7	0.55	-	1.2	0.37	-	2.8	1.8	2.2	1.8	0.55	1.7	0.55	-	1.2	0.37	-
02A6-4	3.5	2.6	3.2	2.6	0.75	2.5	0.75	-	1.8	0.55	-	3.5	2.6	3.2	2.6	0.75	2.5	0.75	-	1.8	0.55	-
03A3-4	4.8	3.3	4.7	3.3	1.1	3.1	1.1	-	2.6	0.75	-	4.8	3.3	4.7	3.3	1.1	3.1	1.1	-	2.6	0.75	-
04A0-4	6.1	4.0	5.9	4.0	1.5	3.8	1.5	-	3.3	1.1	-	6.1	4.0	5.9	4.0	1.5	3.8	1.5	-	3.3	1.1	-
05A6-4	8.5	5.6	7.2	5.6	2.2	5.3	2.2	-	4.0	1.5	-	8.5	5.6	7.2	5.6	2.2	5.3	2.2	-	4.0	1.5	-
07A2-4	10.1	7.2	10.1	7.2	3.0	6.8	3.0	-	5.6	2.2	-	10.1	7.2	10.1	7.2	3.0	6.8	3.0	-	5.6	2.2	-
09A4-4	12.9	9.4	13.0	9.4	4.0	8.9	4.0	-	7.2	3.0	-	12.9	9.4	13.0	9.4	4.0	8.9	4.0	-	7.2	3.0	-
12A6-4	16.5	12.6	16.9	12.6	5.5	12.0	5.5	-	9.4	4.0	-	16.5	12.6	16.9	12.6	5.5	12.0	5.5	-	9.4	4.0	-
17A0-4	23.4	17.0	22.7	17.0	7.5	16.2	7.5	-	12.6	5.5	-	23.4	17.0	22.7	17.0	7.5	16.2	7.5	-	12.6	5.5	-
25A0-4	31.8	25.0	30.6	25.0	11.0	23.8	11.0	-	17.0	7.5	-	31.8	25.0	30.6	25.0	11.0	23.8	11.0	-	17.0	7.5	-
033A-4	40.9	32.0	45.0	32.0	15.0	30.5	15.0	-	25.0	11.0	-	40.9	32.0	45.0	32.0	15.0	30.5	15.0	-	25.0	11.0	-
032A-4	40.7	32.0	45.0	32.0	15.0	30.5	15.0	-	25.0	11.0	-	40.7	32.0	45.0	32.0	15.0	30.5	15.0	-	25.0	11.0	-
038A-4	49.0	38.0	57.6	38.0	18.5	36.0	18.5	-	32.0	15.0	-	49.0	38.0	57.6	38.0	18.5	36.0	18.5	-	32.0	15.0	-
045A-4	55.7	45.0	68.4	45.0	22.0	42.8	22.0	-	38.0	18.5	-	55.7	45.0	68.4	45.0	22.0	42.8	22.0	-	38.0	18.5	-
050A-4	55.7	50.0	81.0	50.0	22.0	48.0	22.0	-	45.0	22.0	-	55.7	50.0	81.0	50.0	22.0	48.0	22.0	-	45.0	22.0	-
3-phase $U_N = 480$ V																						
01A8-4	2.2	1.6	2.2	-	-	1.6	-	0.75	1.1	-	0.5	2.2	1.6	2.2	-	-	1.6	-	0.75	1.1	-	0.5
02A6-4	2.7	2.1	3.2	-	-	2.1	-	1.0	1.6	-	0.75	2.7	2.1	3.2	-	-	2.1	-	1.0	1.6	-	0.75
03A3-4	3.9	3.0	4.7	-	-	3.0	-	1.5	2.1	-	1.0	3.9	3.0	4.7	-	-	3.0	-	1.5	2.1	-	1.0
04A0-4	4.5	3.4	5.9	-	-	3.4	-	2.0	3.0	-	1.5	4.5	3.4	5.9	-	-	3.4	-	2.0	3.0	-	1.5
05A6-4	6.6	4.8	7.2	-	-	4.8	-	3.0	3.5	-	2.0	6.6	4.8	7.2	-	-	4.8	-	3.0	3.5	-	2.0
07A2-4	6.2	6.0	10.1	-	-	6.0	-	3.0	4.8	-	3.0	6.2	6.0	10.1	-	-	6.0	-	3.0	4.8	-	3.0
09A4-4	9.8	7.6	13.0	-	-	7.6	-	5.0	6.0	-	3.0	9.8	7.6	13.0	-	-	7.6	-	5.0	6.0	-	3.0
12A6-4	13.9	11.0	16.9	-	-	11.0	-	7.5	7.6	-	5.0	13.9	11.0	16.9	-	-	11.0	-	7.5	7.6	-	5.0
17A0-4	18.8	14.0	22.7	-	-	14.0	-	10.0	11.0	-	7.5	18.8	14.0	22.7	-	-	14.0	-	10.0	11.0	-	7.5
25A0-4	26.6	21.0	30.6	-	-	21.0	-	15.0	14.0	-	10.0	26.6	21.0	30.6	-	-	21.0	-	15.0	14.0	-	10.0
033A-4	33.9	27.0	45.0	-	-	27.0	-	20.0	21.0	-	15.0	33.9	27.0	45.0	-	-	27.0	-	20.0	21.0	-	15.0
032A-4	33.7	27.0	45.0	-	-	27.0	-	20.0	21.0	-	15.0	33.7	27.0	45.0	-	-	27.0	-	20.0	21.0	-	15.0
038A-4	41.3	34.0	57.6	-	-	34.0	-	25.0	27.0	-	20.0	41.3	34.0	57.6	-	-	34.0	-	25.0	27.0	-	20.0
045A-4	46.9	40.0	68.4	-	-	40.0	-	30.0	34.0	-	25.0	46.9	40.0	68.4	-	-	40.0	-	30.0	34.0	-	25.0
050A-4	46.9	42.0	81.0	-	-	42.0	-	30.0	40.0	-	30.0	46.9	42.0	81.0	-	-	42.0	-	30.0	40.0	-	30.0

- I_A Input current for 230 V and 400 V with motor power P_N (kW), and for 480 V with motor power P_{Ld} (hp).
 - I_{max} Maximum output current. Available for 2 seconds every 10 minutes when the output frequency is less than 9 Hz.
 - I_N Nominal output current. Maximum continuous rms output current (no overload).
 - I_{Ld} Continuous rms output current. Allows 10% overload for 1 minute every 10 minutes.
 - I_{Hd} Continuous rms output current. Allows 50% overload for 1 minute every 10 minutes.
 - P_N Typical motor power in nominal use (no overload)
 - P_{Ld} Typical motor power in light-duty use (10% overload)
 - P_{Hd} Typical motor power heavy-duty use (50% overload)
- The kilowatt ratings are applicable to most IEC 4-pole motors. The horsepower ratings are applicable to most NEMA 4-pole motors.

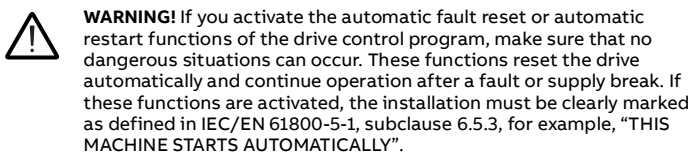

Fieldbus communication

Fieldbus communication with the BMIO-01 I/O module

- Select **Modbus RTU** from the Control macros view. The drive changes some parameter values automatically.
- Configure fieldbus communication from the parameter list. The minimum set of parameters for Modbus RTU configuration:

No.	Name	Value
20.01	Ext1 commands	Embedded fieldbus
22.11	Ext1 speed ref1 (vector)	EFB ref1
28.11	Ext1 frequency ref1 (scalar)	EFB ref1
31.11	Fault reset selection	DI1
58.01	Protocol enable	Modbus RTU
58.03	Node address	1 (default)
58.04	Baud rate	19.2 kbps (default)
58.05	Parity	8 EVEN 1 (default)

Fieldbus communication with a fieldbus adapter module

The drive automatically identifies the connected adapter and selects the correct fieldbus control macro. If necessary, configure the adapter-specific settings. Refer to the applicable fieldbus adapter documentation.

Warnings and faults

Warning	Fault	Description
A2A1	2281	Warning: Current calibration is done at the next start. Fault: Output phase current measurement fault.
A2B1	2310	Overcurrent: The output current is more than the internal limit. This can be caused by an earth fault or phase loss.
A2B3	2330	Earth leakage: A load unbalance that is typically caused by an earth fault in the motor or the motor cable.
A2B4	2340	Short circuit: A short circuit in the motor or the motor cable.
-	3130	Input phase loss: The intermediate DC circuit voltage oscillates.
-	3181	Cross connection: The input and motor cable connections are incorrect.
A3A1	3210	DC link overvoltage: Intermediate DC circuit voltage too high.
A3A2	3220	DC link undervoltage: Intermediate DC circuit voltage too low.
-	3381	Output phase loss: All three phases are not connected to the motor.
A5A0	5091	Safe torque off: The Safe torque off (STO) function is active.
-	6681	EFB communication loss: A loss in embedded fieldbus communications.
-	7510	FBA A communication loss: A loss in communications between drive and fieldbus adapter.
AFF6	-	Identification run: Motor ID run occurs at the next start.
-	FA81	Safe torque off 1: Safe torque off circuit 1 is broken.
-	FA82	Safe torque off 2: Safe torque off circuit 2 is broken.

Ratings

ACS380-04xx-...	Input ratings			Output ratings																		
	No choke	With choke	Max. current	Nominal use				Light-duty use				Heavy-duty use										
	I_A	I_A	I_{max}	I_N	P_N	I_{Ld}	P_{Ld}	I_{Hd}	P_{Hd}	I_A	P_A	I_{Hd}	P_{Hd}	I_A	P_A	I_{Hd}	P_{Hd}					
1-phase $U_N = 230$ V																						
02A4-1	5.5	4.2	3.2	2.4	0.37	2.3	0.37	0.5	1.8	0.25	0.33	5.5	4.2	3.2	2.4	0.37	2.3	0.37	0.5	1.8	0.25	0.33
03A7-1	7.4	6.4	4.3	3.7	0.55	3.5	0.55	0.75	2.4	0.37	0.5	7.4	6.4	4.3	3.7	0.55	3.5	0.55	0.75	2.4	0.37	0.5
04A8-1	9.1	8.3	6.7	4.8	0.75	4.6	0.75	1.0	3.7	0.55	0.75	9.1	8.3	6.7	4.8	0.75	4.6	0.75	1.0	3.7	0.55	0.75
06A9-1	12.6	11.9	8.6	6.9	1.1	6.6	1.1	1.5	4.8	0.75	1.0	12.6	11.9	8.6	6.9	1.1	6.6	1.1	1.5	4.8	0.75	1.0
07A8-1	14.9	13.5	12.4	7.8	1.5	7.4	1.5	2.0	6.9	1.1	1.5	14.9	13.5	12.4	7.8	1.5	7.4	1.5	2.0	6.9	1.	